

# KLIP-LOK CLASSIC<sup>®</sup> 700

**LYSAGHT**

DESIGN AND INSTALLATION GUIDE



INSPIRATION TO BUILD BETTER

# LYSAGHT KLIP-LOK CLASSIC® 700

KLIP-LOK CLASSIC® 700 features a strong rib for excellent spanning capacity. Visually, the strong rib makes a bold statement rising from flat pans with longitudinal fluting. Clips permit thermal expansion of long, straight runs, and because there are no piercings through the cladding; the long, straight lines of KLIP-LOK CLASSIC® 700 remain crisp and clean. And no piercings means superb weatherproof performance.

Our new fixing clip can be laid in place and fixed quickly and easily. This is because the KLIP-LOK CLASSIC® 700 clip is fixed with hex. head screws, which are easier to drive.

Long lengths of KLIP-LOK CLASSIC® 700 are available subject to state delivery guidelines.

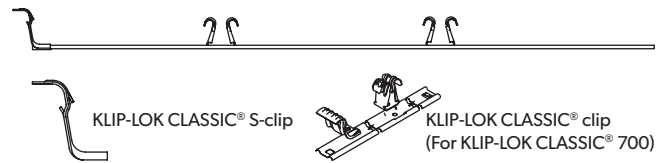
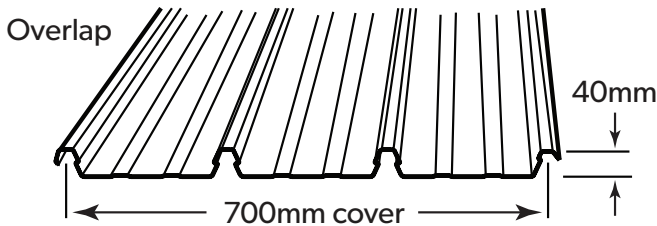

## MATERIAL SPECIFICATIONS

Next generation ZINCALUME® aluminium/zinc/magnesium alloy coated steel complies with AS 1397 G550, AM125 (550 MPa minimum yield stress, 125g/m<sup>2</sup> minimum coating mass).

COLORBOND® pre-painted steel for exterior roofing and walling. It is the most widely used. The painting complies with AS/NZS 2728 and the steel base is an aluminium/zinc alloy-coated steel complying with AS 1397. Minimum yield strengths are G550 (550 MPa). Minimum coating mass is AM100 (100g/m<sup>2</sup>).

COLORBOND® Metallic steel for superior aesthetic qualities displaying a metallic sheen.

COLORBOND® Ultra steel for severe coastal or industrial environments (generally within about 100-200 metres of the source). The painting complies with AS/NZS 2728 and the steel base is an aluminium/zinc alloy-coated steel complying with AS 1397. Minimum yield strength is G550 (550 MPa). Minimum coating mass is AM150 (150g/m<sup>2</sup>).

SUPERDURA® Stainless steel for severe coastal or industrial environments. The painting complies with AS/NZS 2728 and the steel base is a stainless steel complying with AISI/ASTM Type 430; UNS No. S43000.

## COLORBOND® STEEL WITH THERMATECH® TECHNOLOGY

COLORBOND® steel's core colour range in the Classic and Matt finish features our specially designed Thermatech® solar reflectance technology. Thermatech® reflects more of the sun's heat on hot, sunny days which may help increase your comfort while reducing your dependence on air conditioning\*. Thermatech® is available in all core colours except Night Sky®.

## MATERIAL AND COLOUR AVAILABILITY

For local availability of KLIP-LOK CLASSIC® 700 in the base metal thicknesses or the large range of available finishes (from plain ZINCALUME® steel to COLORBOND® pre-painted steel), contact your nearest Lysaght service centre.

For the local availability of colours, metallic finish or stainless steel for KLIP-LOK CLASSIC® 700 please enquire at your nearest Lysaght branch.

## MASSES

	BMT (mm)	kg/m	kg/m <sup>2</sup>	m <sup>2</sup> /t
ZINCALUME® steel	0.42	3.23	4.61	217
COLORBOND® steel	0.42	3.26	4.65	215
ZINCALUME® steel	0.48	3.67	5.24	191
COLORBOND® steel	0.48	3.70	5.28	189

## TOLERANCES

Length: + 0mm, - 15mm, Width: + 4mm, - 4mm

Make allowance for thermal expansion or contraction for long length roofs at sheeting ends.

The equation  $\Delta L = \alpha \times \Delta T \times L$  gives an indication of the sheeting extent or contraction ( $\Delta L$ ).

$\alpha = 12 \times 10^{-6}$  (coefficient of linear expansion for steel)

$\Delta T$  = temperature change in °C

L = sheet length in mm

## MAXIMUM SUPPORT SPACINGS

The maximum recommended support spacings are based on testing in accordance with AS 1562.1, AS 4040.0 and AS 4040.1.

Roof spans consider both resistance to wind pressure and light roof traffic (traffic arising from incidental maintenance).

Wall spans consider resistance to wind pressure only.

These spacings may be governed by serviceability and strength limit states for particular projects.

The pressure considered is based on buildings up to 10m high in Regions A & B, Terrain Category 3,  $M_s=0.85$ ,  $M_1=1.0$ ,  $M_t=1.0$  with the following assumptions made:

## ROOFS:

$C_{pi} = +0.20$ , (Region A:  $C_{pe} = -0.65$ ) (Region B:  $C_{pe} = -0.90$ ),

## WALLS:

$C_{pi} = 0.20$ ,  $C_{pe} = -0.65$

Region B:  $K_f = 2.0$  for single and end spans,  $K_f = 1.5$  for internal spans. Region A:  $K_f = 2.0$  for all spans.

## MAXIMUM SUPPORT SPACINGS (mm)

Type of Span	BMT			
	0.42mm	0.48mm	0.42mm	0.48mm
	Region A	Region A	Region B	Region B
<b>Roofs</b>				
Single span	1600	2000	1600	2000
End span	200	2600	1800	2100
Internal span	2700	3000#	2600	3000#
Unstiffened eaves overhang	200	250	200	250
Stiffened eaves overhang	500	600	500	600
<b>Walls</b>				
Single span	2150	2550	2000	2450
End span	2900	3000#	2300	2550
Internal span	3000#	3000#	3000#	3000#
Overhang	300	400	300	400

For roofs: the data are based on foot-traffic loading.

For walls: the data are based on pressures.

Table data are based on supports of 1mm BMT. For material less than 1.0mm thick, refer to the TOPSPAN® Design and Installation Manual and Selection Tables, or seek advice from our information line.

# Span in excess of 3000mm may be available subject to enquiry.

## SPAN TYPES

### Roofing & Walling Profiles

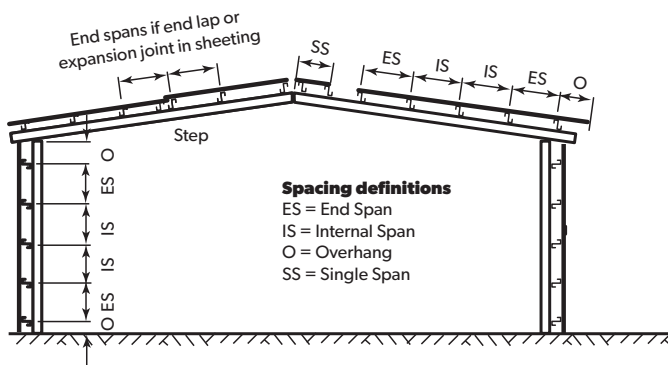

### Walling Profiles Only

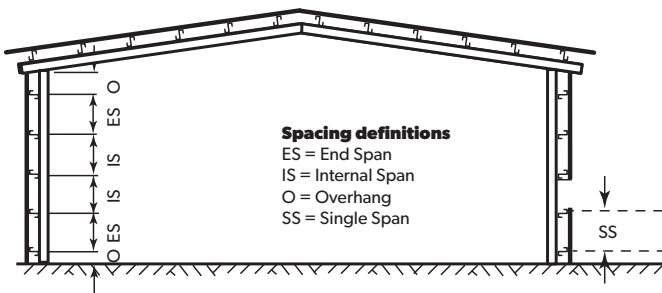

## MAXIMUM ROOF LENGTHS FOR DRAINAGE MEASURED FROM RIDGE TO GUTTER

Penetrations will alter the flow of water on a roof. For assistance in design of roofs with penetrations, please seek advice from our information line.

## MAXIMUM ROOF LENGTHS FOR DRAINAGE (M)

Peak Rainfall Intensity (mm/hr)	Roof Slopes (degrees)					
	1	2	3	5	7.5	10
100	247	308	36	449	536	616
150	165	205	241	300	357	411
200	124	154	181	225	268	308
250	99	123	144	180	214	246
300	82	103	120	150	179	205
333	74	93	108	135	161	185
500	49	62	72	90	107	123

## MINIMUM ROOF PITCH

Our unique anti-capillary side-lap allows you to use KLIP-LOK CLASSIC® 700 on roof pitches from as low as 1° (1 in 50) for 0.48 BMT, and 2° (1 in 30) for 0.42 BMT.

## LIMIT STATES WIND PRESSURES

KLIP-LOK CLASSIC® 700 offers the full benefits of the latest methods for modelling wind pressures. The wind pressure capacity table is determined by full scale tests conducted at Lysaght's NATA-registered testing laboratory, using the direct pressure-testing rig.

Testing was conducted in accordance with AS 1562.1, and AS 4040.2.

The pressure capacities for serviceability are based on a deflection limit of  $(\text{span}/120) + (\text{maximum fastener pitch}/30)$ .

The pressure capacities for strength have been determined by testing the cladding to failure (ultimate capacity). These pressures are applicable when the cladding is fixed to a minimum of 1.0mm, G550 steel. For material less than 1.0mm thick, refer to the TOPSPAN® Design and Installation Guide and Selection Tables, or seek advice from our information line.

Refer KLIP-LOK CLASSIC® 700 Limit State wind pressure capacities tables on the following page.

## NON-CYCLONIC AREAS

The information in this brochure is suitable for use only in areas where a tropical cyclone is unlikely to occur as defined in AS/NZS 1170.2.

For information on the use of LYSAGHT® products in cyclonic conditions, refer to the Cyclonic Area Design Manual which is available on our website: [www.lysaght.com](http://www.lysaght.com).



## ADVERSE CONDITIONS

If this product is to be used in marine, severe industrial, or unusually corrosive environments, ask for advice from our information line.

## KLIP-LOK CLASSIC® 700 LIMIT STATE WIND PRESSURE CAPACITIES (KPA) 0.42 BMT

Span Type	Limit State	Span (mm)							
		900	1200	1500	1800	2100	2400	2700	3000
Single	Serviceability	2.24	2.15	1.75	1.26	0.93	0.73	0.57	0.44
	Strength	5.15	4.78	3.28	2.48	1.91	1.50	1.18	0.93
End	Serviceability	2.03	1.91	1.87	1.61	1.37	1.16	0.97	0.82
	Strength	4.67	3.23	3.17	2.75	2.34	1.93	1.57	1.28
Internal	Serviceability	1.94	1.70	1.70	1.70	1.70	1.59	1.46	1.32
	Strength	3.69	3.17	3.15	2.93	2.66	2.35	2.03	1.78

## KLIP-LOK CLASSIC® 700 LIMIT STATE WIND PRESSURE CAPACITIES (KPA) 0.48 BMT

Span Type	Limit State	Span (mm)							
		900	1200	1500	1800	2100	2400	2700	3000
Single	Serviceability	3.00	2.60	2.26	1.72	1.31	1.02	0.77	0.57
	Strength	6.22	5.20	3.86	3.25	2.68	2.15	1.65	1.20
End	Serviceability	2.89	2.68	2.68	2.62	2.55	1.80	1.26	0.95
	Strength	5.88	4.49	3.76	3.23	2.79	2.31	1.86	1.50
Internal	Serviceability	2.58	2.54	2.54	2.34	2.14	1.90	1.68	1.47
	Strength	4.78	4.29	3.96	3.30	2.93	2.68	2.52	2.22

Table data are based on minimum support G550 steel, 1.0mm BMT.

# INSTALLATION

### PREPARATION

Before starting work ensure that:

- The supports for your cladding are truly in the same plane, this is critical if the roof slope is  $\leq 5^\circ$ .
- The minimum roof slopes conform to our recommendations.
- The overhangs of sheets from the top and bottom supports don't exceed our recommendations.
- The first and last supports and clips should be at least 75mm from each end of the sheet to keep maximum holding power.

Make any necessary adjustments before you start laying sheets, because they will be difficult to rectify later.

### ORIENT SHEETS BEFORE LIFTING

Consider which end of the building is best to start from. For maximum weather-tightness, start laying sheets from the end of the building that will be downwind of the worst-anticipated or prevailing weather (Figure 1).

#### Figure 1:

Lay sheets towards prevailing weather.

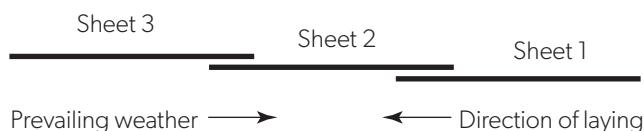

It is much easier and safer to turn sheets on the ground than up on the roof. Before lifting sheets on to the roof, check that they are the correct way up and the overlapping side is towards the edge of the roof from which installation will start.

Place bundles of sheets over or near firm supports, not at mid span of roof members.

### KLIP-LOK CLASSIC® 700 INSTALLATION

1. Lay and fix wire mesh to the supports and glass wool insulation in accordance with the appropriate building requirements.
2. Position the first clips on each support by placing onto the support nearest the roof edge (Figure 2).

#### Figure 2:

Sequence of laying.

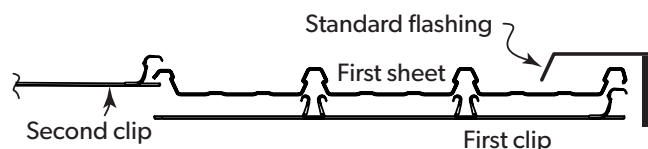

3. Fix the first clip on the support so they point in the direction of laying. Ensure the clip is 90 degrees to the edge of the sheet.
4. Align the clips using a string line (Figure 3) or the first sheet as a straight edge to align the clips as you fix a clip to each support working towards the high end of the roof.

#### Figure 3:

Use a stringline to ensure first row of clips is aligned. Fix first row of clips.

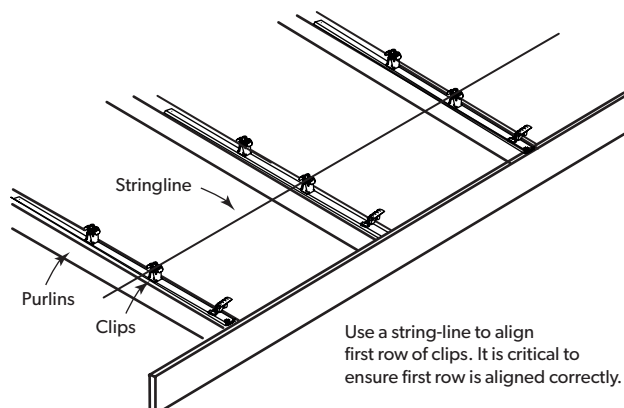

Use a string-line to align first row of clips. It is critical to ensure first row is aligned correctly.



5. Drive hex-head screws through the top of the clip, into the support.
6. Work along the edge of the roof, ensuring it aligns correctly at its ends in relation to the gutter and ridge or parapet or transverse wall.
7. Position the first sheet so that it overhangs the desired amount (minimum 50mm) to the gutter. It is important to ensure this first sheet is placed square to adjacent edges (Figure 4a)

**Figure 4a:**

Placing the first sheet.

**KLIP-LOK CLASSIC®**

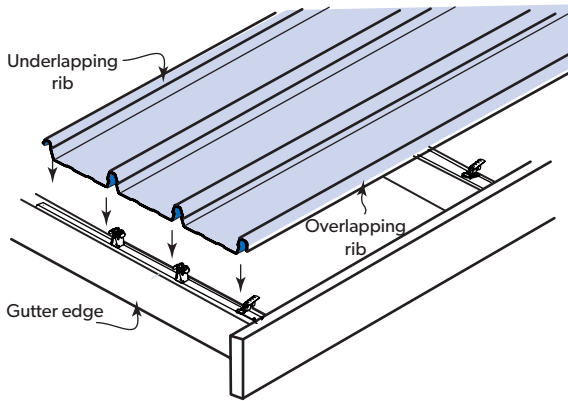

8. Engage the sheet with clips using vertical foot pressure on all the ribs over each clip.
9. Fix the initial overlapping rib of the first sheet using an 'S' clip. (For laying sequence, see Figure 4b.)

**Figure 4b:**

Position the 'S' clips over the male lapping rib of the cladding.



10. Fix each next row of clips one to each support by engaging the front of the clip assembly onto the underlap rib of the preceding sheet engaging the spur of the clip to the leading edge of the previous sheet (Figures 5 & 6). Be sure the clip is at 90° to the edge of the sheet.

**Figure 5:**

Fix the next (and subsequent) clips and sheets.

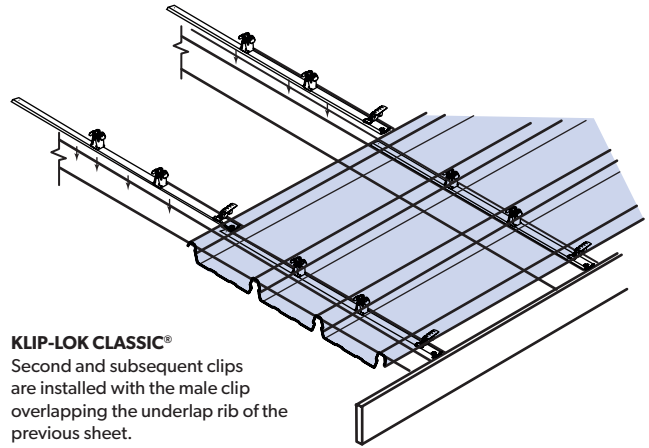

**Figure 6:**

Engaging the next clip to the first sheet.

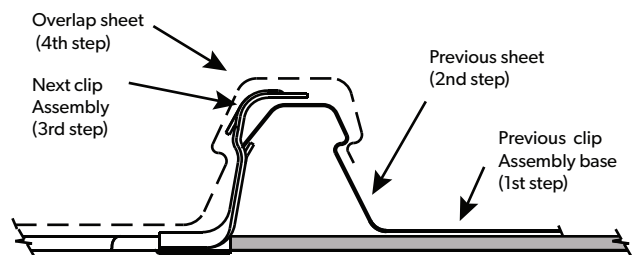

11. As before, place the next sheet over its clips ensuring you also engage the edge of the preceding sheet.

12. Fully engage the two sheets along the overlapping rib. You can do this by walking along the full length of the sheet with one foot in the centre pan of the previous sheet and the other foot applying vertical pressure to the top of the interlocking ribs at regular intervals. It is recommended that you don't walk in the unsupported pan beside the underlapping rib (Figure 7). With long spans, additional care may be required to ensure the overlapping rib adequately engages onto the underlapping leg. Care should be exercised due to the potential instability of the side-lap when it is not adequately engaged (interlocked).

**Figure 7:**

Engaging the lapping ribs.

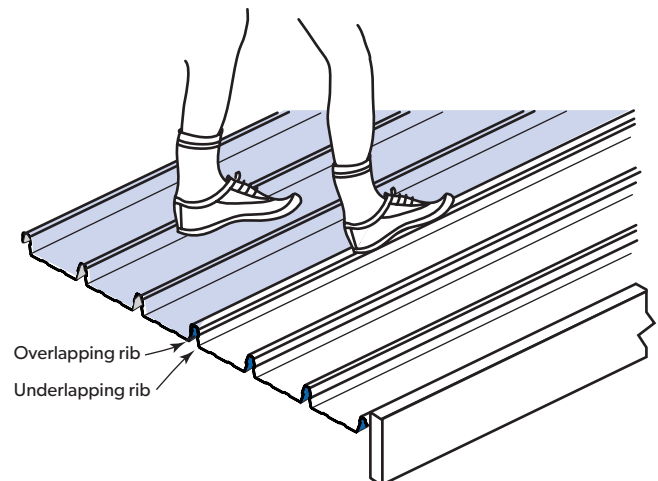

13. Similarly, engage all the clips by applying vertical foot pressure to the top of the other two ribs over each clip. It is essential that the sheets interlock completely. It is important that your weight is fully on the sheet you are installing.
14. Fit an 'S' clip at the last rib of the profile (similar to step 9 when the sheet was started). Both starting and finishing requires an 'S' clip.

**CHECK ALIGNMENT OCCASIONALLY**

Occasionally check that the sheets are still parallel with the first sheet, by taking two measurements across the width of the fixed sheeting. At about half way through the job, perform a similar check but take the measurements from the finishing line to aim for the final sheet to be parallel with the end of the roof. If the measurements are not close enough, lay subsequent sheets very slightly out of parallel to gradually correct the error (Figure 8).

**Figure 8:**

Check alignment occasionally.

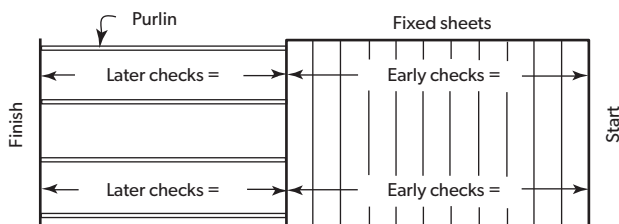

**FIX THE LAST SHEET**

If the final space is less than the full width of a sheet, you can cut a sheet along its length and shorten the clips as appropriate. Installing KLIP-LOK CLASSIC® 700 walls

In walling applications, horizontal pressure will need to be applied locally to the sheets to engage the ribs. Use body pressure (torso, hand or foot) or use a rubber mallet if required. Care should be exercised due to the potential instability of the temporary worker access equipment.

To prevent KLIP-LOK CLASSIC® 700 from sliding downward in the fixing clips, you should pierce-fix through each sheet under the flashing or capping, along the top of the sheets.

In walling applications, horizontal pressure will need to be applied locally to the sheets to engage the ribs. Use body pressure (torso, hand or foot) or use a rubber mallet if required. Care should be exercised due to the potential instability of the temporary worker access equipment.

**INSTALLING KLIP-LOK CLASSIC® 700 WALLS**

To prevent KLIP-LOK CLASSIC® 700 from sliding downward in the fixing clips, you should pierce-fix through each sheet under the flashing or capping, along the top of the sheets.

**LOK-KLIP® AND KLIP-LOK CLASSIC® 700**

The new LOK-KLIP® system provides installers with quick and easy end joint/expansion joint solution between overlapping sheets of KLIP-LOK CLASSIC® 700.

For more details refer to the LOK-KLIP® brochure available on our website [www.lysaght.com](http://www.lysaght.com).

**LOK-KLIP® and KLIP-LOK CLASSIC® 700**

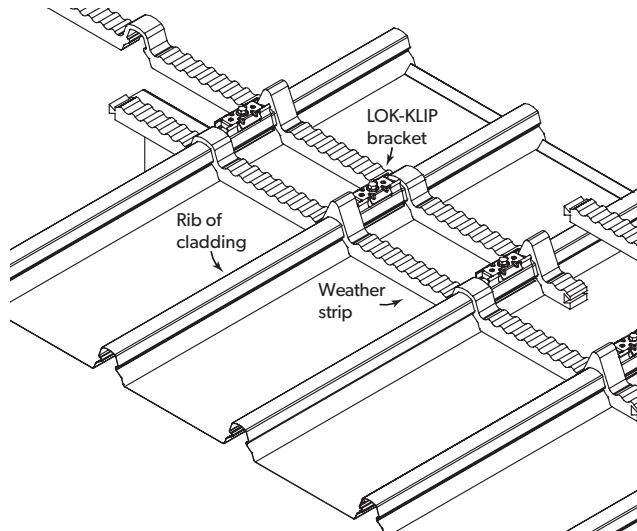

**INSTALLING TRANSLUCENT SHEETS WITH KLIP-LOK CLASSIC® 700**

Because of its greater thermal expansion, translucent cladding should be fixed and sealed using screws and washers recommended by the cladding manufacturer. When used with concealed fixed claddings, ensure the fasteners do not penetrate the steel cladding. There are translucent products available that easily accommodate this.

Note: Don't exceed the maximum support spacing specified by the translucent cladding manufacturer. Use of translucent sheeting may result in lower limit state capacities.

For installation with translucent sheets with LOK-KLIP®, refer to the Ampelite Clearside installation guidelines on LOK-KLIP®.

**COMMERCIAL/INDUSTRIAL DRAINAGE SYSTEMS**

There is a standard procedure for designing the drainage of a roof using an eaves & gutter system. It is assumed that the gutters will have a gradient steeper than 1:500. Box gutter systems can be more complex and are thoroughly treated in AS/NZS 3500.1.

We manufacture the perfect guttering system for your structure, whichever type is appropriate.

All designs can be complemented with our complete range of square and round downpipes and rainwater accessories. To ensure quick and easy installation there is also a full range of matching fixing clips.

**Box gutter**

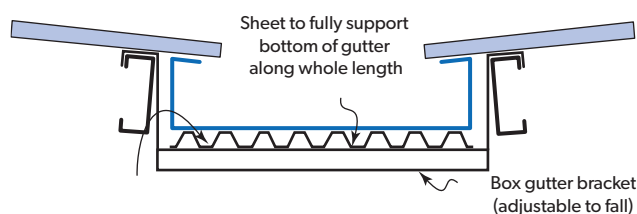

## FASTENERS

Where insulation is to be installed, you may need to increase the length of the screws given below, depending on the density and thickness of the insulation. When the screw is properly tightened:

- **into metal:** there should be at least three threads protruding past the support you are fixing to;
- **into timber:** the screw must penetrate the timber by the same amount that the recommended screw would do if there were no insulation.

## FASTENERS WITH AND WITHOUT INSULATION

Suitable for no insulation or insulation up to 100mm.

	<b>Fix to Steel</b> <b>Single steel thickness</b> <b>≥1.0 BMT up to 3.0mm BMT</b>	<b>Fix to Steel</b> <b>Total lapped thickness</b> <b>≥1.0 BMT up to 3.8mm BMT</b>	<b>Fix to Timber Hardwood</b> <b>J1-J3</b>	<b>Fix to Timber Softwood</b> <b>J4</b>
<b>Clip Fixed</b>	5.4-14x25, Vortex, HH 12-14x30 Concealed Hex Tek's	5.4-14x25, Vortex, HH 12-14x30 Concealed Hex Tek's	5.4-14x25, Vortex, HH	5.4-14x25, Vortex, HH

Notes:

1. For other steel thicknesses not specified please seek advice from screw manufacturer.
2. HH = Hex. Head.
3. Use 3 screws per clip.

## WALKING ON ROOFS

Keep your weight evenly distributed over the soles of both feet to avoid concentrating your weight on either heels or toes. Always wear smooth soft-soled shoes; avoid ribbed soles that pick up and hold small stones, swarf and other objects.

Be careful when moving between supports. Don't walk on ribs, always walk in pans. Do not walk in the pan immediately adjacent to flashings or translucent sheeting. Walk at least one pan away.

## MAINTENANCE

Optimum product life will be achieved if all external surfaces are washed regularly. Areas not cleaned by natural rainfall (such as the tops of walls sheltered by eaves) should be washed down every six months.

## STORAGE AND HANDLING

Keep the product dry and clear of the ground. If stacked or bundled product becomes wet, separate it, wipe it with a clean cloth to dry thoroughly.

Handle materials carefully to avoid damage: don't drag materials over rough surfaces or each other; don't drag tools over material; remove swarf.

## METAL & TIMBER COMPATIBILITY

Lead, copper, free carbon, bare steel and green or some other chemically-treated timbers are not compatible with this product. Don't allow any contact of the product with those materials, nor discharge of rainwater from them onto the product. Supporting members should be coated to avoid problems with underside condensation. If there are doubts about the compatibility of other products being used, ask for advice from our information line.

## CUTTING

For cutting thin metal on site, we recommend a circular saw with a metal-cutting blade because it produces fewer damaging hot metal particles and leaves less resultant burr than does a carborundum disc.

Cut materials on the ground and not over other materials.

Sweep all metallic swarf and other debris from roof areas and gutters at the end of each day and at the completion of the installation. Failure to do so can lead to surface staining when the metal particles rust.

## NOTCHING TOOL

A tool is available for on-site notching of transverse flashings and cappings.

## TURN UP-DOWN TOOLS

On all roofs of pitches less than 15°, the high end of all sheets must be turned up to stop water from being driven under the flashing and into the building.

Similarly, the pans at the gutter end must be turned down to stop water running back along the underside of the sheets.

Tools are available for both applications.

## END-LAPS/EXPANSION JOINTS

End-lapping is not recommended for KLIP-LOK CLASSIC® 700. Expansion joints may be used for long roofs in some conditions. Call your local Lysaght service centre for advice on use of expansion joints and delivery of long length cladding.

## SEALED JOINTS

For sealed joints use screws or rivets and neutral-cure silicone sealant branded as suitable for use with galvanised or ZINCALUME® steel.

## PRODUCT DESCRIPTIONS

- All descriptions, specifications, illustrations, drawings, data, dimensions, and weights contained in this publication and websites containing information from Lysaght are approximations only. They are intended by Lysaght to be a general description for information and identification purposes and do not create a sale by description. Lysaght reserves the right at any time to:

(a) Supply goods with such minor modifications from its drawings and specifications as it sees fit, and

b) Alter specifications shown in its publications and websites to reflect changes made after the date of publication.

## DISCLAIMER, WARRANTIES AND LIMITATION OF LIABILITY

- This publication is intended to be an aid for all trades and professionals involved with specifying and installing LYSAGHT® products and not be a substitute for professional judgement.
- Terms and conditions of sale are available at [lysaght.com/terms](https://lysaght.com/terms)
- Except to the extent to which liability may not lawfully be excluded or limited, BlueScope Steel Limited will not be under or incur any liability to you for any direct or indirect loss or damage (including, without limitation, consequential loss or damage such as loss of profit or anticipated profit, loss of use, damage to goodwill and loss due to delay) however caused (including, without limitation, breach of contract, negligence and/or breach of statute), which you may suffer or incur in connection with this publication.

## AUSTRALIAN STANDARDS

Australian Standard	Definition
AS/NZS 2728:2013	Prefinished/pre-painted sheet metal products for interior/exterior building applications — Performance requirements
AS 1397:2021	Continuous hot-dip metallic coated steel sheet and strip — Coatings of zinc and zinc alloyed with aluminium and magnesium
AS 1562.1:2018	Design and installation of metal roof and wall cladding, Part 1: Metal
AS 4040.0-1992	Methods of testing sheet roof and wall cladding
AS 4040.1-1992 (Reconfirmed 2016)	Methods of testing sheet roof and wall cladding - Method 1: Resistance to concentrated loads
AS 4040.2-1992 (Reconfirmed 2016, Amendment 1:2018)	Methods of testing sheet roof and wall cladding, Part 2: Resistance to wind pressures for non-cyclone regions
AS/NZS 1170.2:2021	Structural design actions, Part 2: Wind actions
AS/NZS 3500.1:2021	Plumbing and drainage, Part 1: Water services

FOR DETAILED PRODUCT INFORMATION,  
MANUALS AND PROJECT CASE STUDIES VISIT:

[WWW.LYSAGHT.COM](https://www.lysaght.com)

Thermatech® solar reflectance technology is not available in Night Sky®, or non-standard colours, and is not available in SUPERDURA® Stainless steel, COLORBOND® Metallic steel, or COLORBOND® Coolmax® steel.

COLORBOND®, SUPERDURA®, ZINCALUME®, Thermatech®, LYSAGHT® and © product names are registered trademarks of BlueScope Steel Limited and ™ product names are trademarks of BlueScope Steel Limited. © 2024 BlueScope Steel Limited. ABN 16 000 011 058. All rights reserved.

INSPIRATION TO BUILD BETTER

