

DOUBLE CARPORT



10 STEP CONSTRUCTION GUIDE FOR FREESTANDING CARPORTS

6.125 X 5.65M
CYCLONIC AREAS



DOUBLE CARPORT CONSTRUCTION

STEP BY STEP GUIDE FOR THE PERFECT CARPORT PROJECT

Building a carport using LYSAGHT® steel products offers clear advantages for both the builder and homeowner alike. Construction is made easier with dimensionally accurate and quality components joined using custom made connectors.

For the homeowner, long term enjoyment is assured with the pre-painted, corrosion resistant materials.

As with all building materials there are some particular things you should keep in mind to ensure you get the full benefits of using LYSAGHT® steel building products.

PACK SIZE AND WEIGHT

Pack size approximately 6200mm (L) x 800mm (W) x 50mm (H).

Pack weight approximately 180kg for single carports and 280kg for double carports.

STEP 1 - component check

Find a level area in your front or back yard and place all of the delivered components so they are identifiable. Extra fasteners are included in addition to actual quantities required to build the carport.

Check the following components off against the bill of materials from the Lysaght delivery receipt.

FIRMLOK® beam (x2) (F150)
FIRMLOK® beam (x4) (F200)

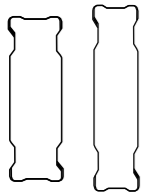

FIRMLOK® brackets 150mm (x4) (CONB150)
FIRMLOK® brackets 200mm (x8) (CONB200)

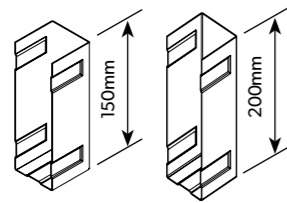

Gutter (x1)

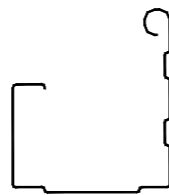

Gutter stop-ends (x2)

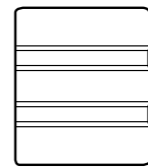

Hexhead Bolts x 60mm (FBC60)

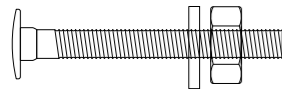

Hexhead Bolts x 110mm (FBC110)

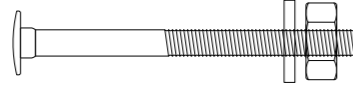

Metal Tek® 14-10 x 150mm (FT150N)



Metal Tek® 12-14 x 50 (FT50M)



Metal Tek® 12-14 x 20 (FT20M)



3.2mm Rivet (FR72)

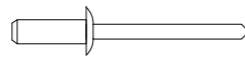

Metal Tek® 12-14 x 50 (FT50-WCA with EPDM and cyclonic washer)

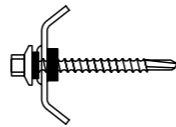

Steel post (x4) (PS90)

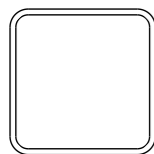

SPANDEK® 0.42mm (x8 sheets) (RS3)

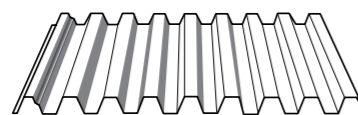

Gutter bracket (x8) (GSTRAP)

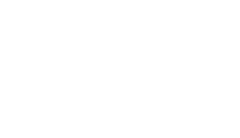

Roof sign (x1) (LABEL)



Silicone (x1) (SILIC)



Barge capping 0.55mm (x3) (BC1)



STEP 2 - what tools & materials do you need?

- Step ladder
- Hack saw
- Tape measure
- Pliers and tin snips
- Angle grinder
- Spirit or laser level
- Rivet gun
- Post hole digger or shovel
- PVC downpipe & strap
- Electrical lead
- PVC downpipe elbow
- Silicone gun & clear silicone
- String line/ stakes
- Ratchet wrench
- Safety equipment (PPE)
- Adjustable stands (props) and clamps
- Adjustable spanner
- Bags of concrete
- Drill & adaptors
- Saw horses and planks

STEP 3 - before you start!

It is recommended that all LYSAGHT® carports are assembled and installed under the supervision and direction of a person with some level of building experience.

Safety is of utmost importance at all times. Always make sure that even basic construction tasks are done utilising safe building practices.

It is very important to read both the installation instructions and the supplied construction drawing. They should both be referred to in preparation for the installation and at every step during the construction process.

Every dimension, hole location and level should be double checked for good measure before cutting, fixing, screwing or bolting to any structural component.

Your carport is designed to resist wind uplift and the footing size is based on the wind classification. If in doubt, go to the Lysaght website (www.lysaght.com) and use the wind classification system to check the design wind speed or seek expert advice to ensure correct wind classification is selected.

If you do not have the necessary tools or know-how, please contact your local Lysaght branch for guidance.

STEP 4 - marking out the carport position

Use in-ground stakes and tie up string lines to position the steel post locations referring to the construction drawing. Check diagonals are equal for a square shape.

FIRMLOK® beams and SPANDEK® sheeting lengths are reliant upon these measures being 100% accurate.

Check depth and width of the footing according to the construction drawing and remove soil.

Mark and cut posts to length and prepare the bottom of the posts as per the construction drawing with intersecting fixings and add the connectors to the top of the posts.

Ensure the footings holes are aligned and the final intended locations of posts correct in accordance with the construction drawing. Slopes of the ground will need to be taken into consideration to ensure holes are dug to appropriate depth and posts are subsequently aligned in terms of height.

Once the digging is complete, simply place bricks/pavers squarely in the bottom of each hole so the posts can be positioned on solid ground.

Place the posts in the holes and clamp off in position and brace with a fall towards the end at which the gutter system will be positioned. The fall needs to be a minimum 30mm for every 1m in length.

STEP 5 - laying out the beams

Using the drawing, lay the beams close to the point where they will be assembled.

INTERMEDIATE PURLIN

You will have two FIRMLOK® F200 beams that are the shortest – these are your intermediate purlins.

HEAD BEAMS

You will have to received two FIRMLOK® F150 beams – these are your head beams.

RETURN BEAMS

You will have received two FIRMLOK® F200 beams that are the longest in length – these are your return beams.

PLEASE NOTE: Beams may need to be cutback to match the correct length as specified on construction drawing.

FRAME ASSEMBLY

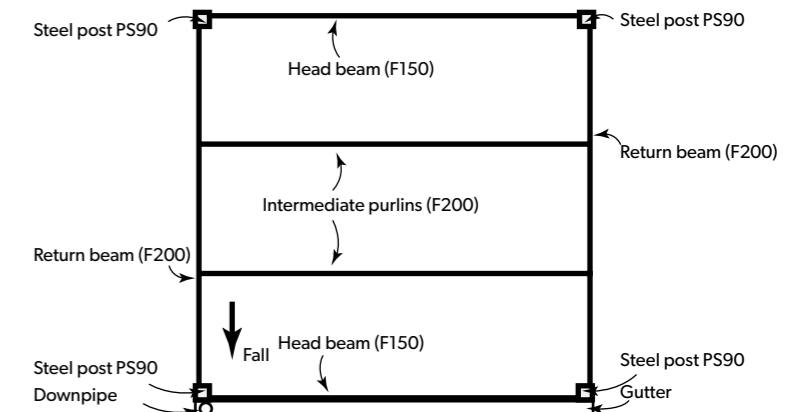

STEP 6 - assembling the frame and posts

HEAD AND RETURN BEAMS - CONNECTION TO POSTS

Place the head beams on adjustable stands (props) and level the front and rear head beams at the correct height, also ensuring you have the correct fall. The FIRMLOK® beam ends sits inside the connectors.

INTERMEDIATE PURLIN - CONNECTION TO RETURN BEAMS

The universal beam connectors are fixed to the return beams using the appropriate fasteners at points 1/3 of the length of the return beams. The FIRMLOK® beams sit inside the connectors. Note that the connectors for the intermediate purlins should be fixed to the return beams before they are lifted up to the posts.

With the framework now in place, double check every dimension against the construction drawing provided and check the diagonals for good measure.

See Step 8 for determining the final width of the structure to see if the sheeting width measured in Step 8 is bigger than the drawing width.

There is tolerance in each of the head beam connectors in case you need to make the structure slightly wider.

With the measurements checked you can now fix through the beam connectors to complete frame assembly.

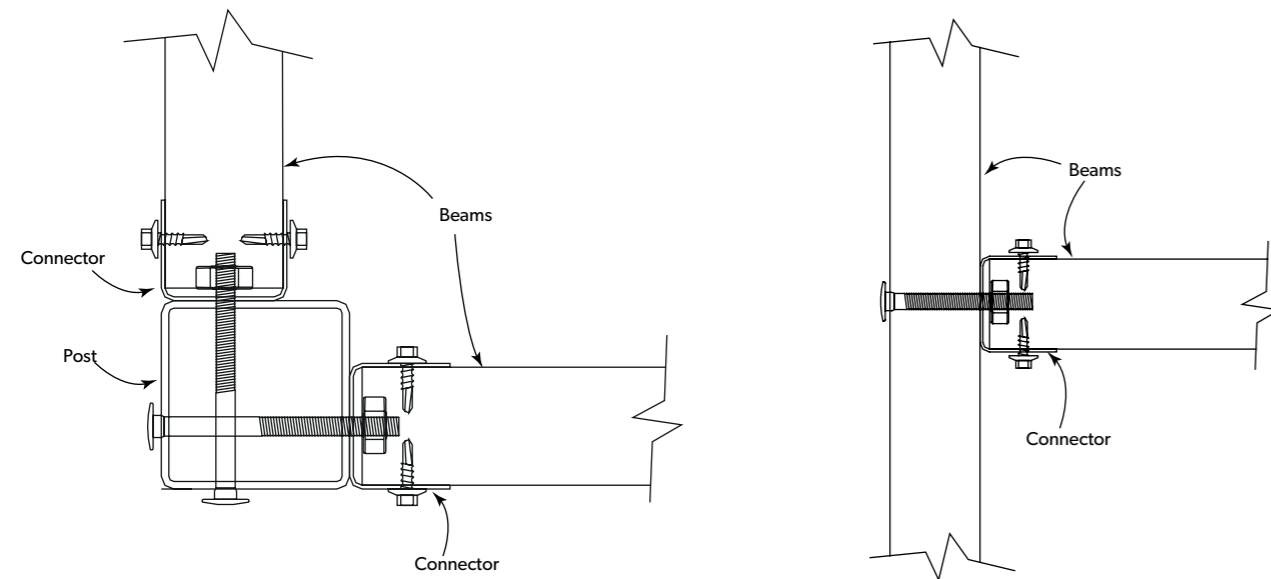

STEP 7 - fixing the posts

Mix the concrete as per manufacturers instructions and pour into holes, ensuring posts are plumb in both directions.

The concrete should be finished slightly raised at the post, ensuring water runs away from the post.

Leave overnight or until concrete has fully cured and posts are firmly fixed in place.

The props can now be removed.

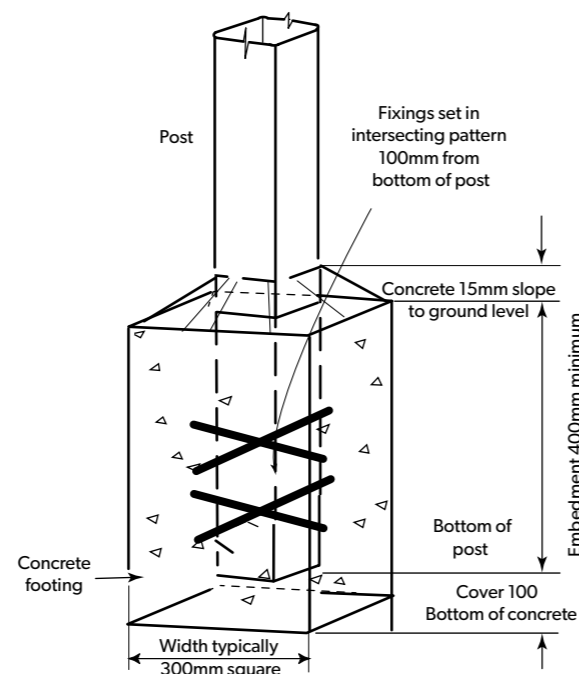

STEP 8 - roof sheeting

Lay the SPANDEK® roof sheeting from one side of the structure to the other on the ground and measure the overall width. Check this against the width on the drawing.

The diagram below indicates the correct laying direction and details the lapping necessary to ensure correct installation of roofing material.

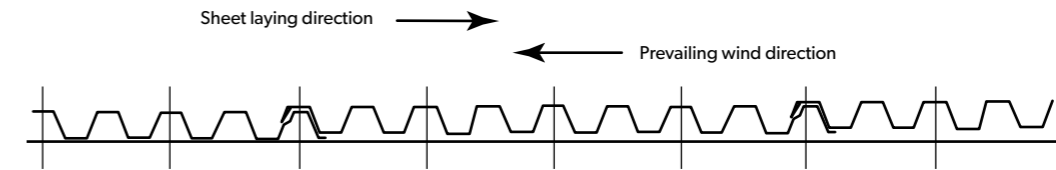

You must lay the first sheet at the opposite side of the prevailing wind direction to ensure lapping is protected from conditions.

Fix each sheet in place as you move along the structure as stipulated in the construction drawing provided.

Start each new sheet in this fashion until the whole structure is covered.

Be careful not to over-tighten the screws as this will crush the ribs and spread the sheet wider.

PLEASE NOTE: Depending on your sheet type and colour it may have corestrip plastic on underside of sheet, this is to be removed before fixing your sheeting.

STEP 9 - gutter installation

Proceed to attach both ends of the gutter with end stops using the specified fixings. Silicon seal to ensure a waterproof finish.

Measure the hole at the lower end of the gutter to suit the size of the downpipe nozzle. Install by using specified fixings and seal with silicone.

Make certain the hole lines up with the post where the downpipe will go.

Fix the gutter to the head beam with supplied brackets evenly spaced as specified on the construction drawing. Make certain the fall is to the intended position of the downpipe.

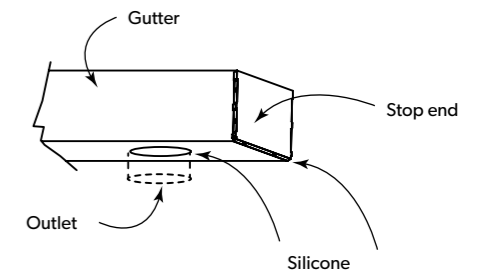

Complete installation of the gutter by attaching the provided gutter straps with the specified fixings at the correct spacings according to the construction drawing.

STEP 10 - barge cappings

As a final step, install barge capping material on the remaining 3 sides of the carport.

The side capping should be attached first – utilising the specified fixings in the construction drawing at the appropriate spacings.

The capping should be attached to the sides of the roof sheeting profile so it sits flush as per diagram.

With the side capping now attached, the top capping should be fixed through the crests on the roof sheeting at the same spacing as specified for the side capping. Silicon seal at overlap of capping.

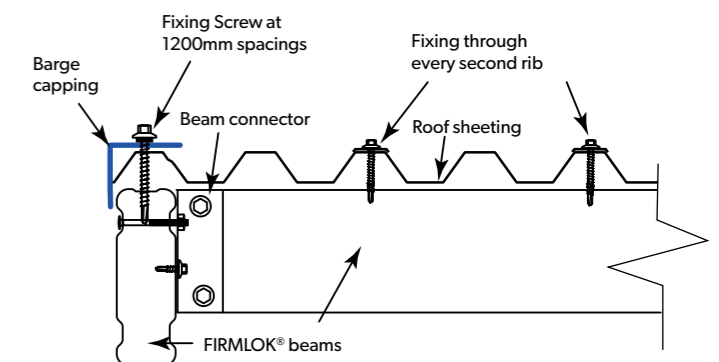

PRODUCT DESCRIPTIONS

- All descriptions, specifications, illustrations, drawings, data, dimensions, and weights contained in this publication and websites containing information from Lysaght are approximations only. They are intended by Lysaght to be a general description for information and identification purposes and do not create a sale by description. Lysaght reserves the right at any time to:
 - a) Supply goods with such minor modifications from its drawings and specifications as it sees fit, and
 - b) Alter specifications shown in its publications and websites to reflect changes made after the date of publication.

DISCLAIMER, WARRANTIES AND LIMITATIONS OF LIABILITY

- This publication is intended to be an aid for all trades and professionals involved with specifying and installing LYSAGHT® products and not be a substitute for professional judgement.
- Terms and conditions of sale are available at lysaght.com/terms
- Except to the extent to which liability may not lawfully be excluded or limited, BlueScope Steel Limited will not be under or incur any liability to you for any direct or indirect loss or damage (including, without limitation, consequential loss or damage such as loss of profit or anticipated profit, loss of use, damage to goodwill and loss due to delay) however caused (including, without limitation, breach of contract, negligence and/or breach of statute), which you may suffer or incur in connection with this publication.

**FOR DETAILED PRODUCT INFORMATION,
MANUALS AND PROJECT CASE STUDIES VISIT:**

[WWW.LYSAGHT.COM](https://www.lysaght.com)

LYSAGHT® and © product names are registered trademarks of BlueScope Steel Limited and ™ product names are trademarks of BlueScope Steel Limited.

© 2023 BlueScope Steel Limited. ABN 16 000 011 058. All rights reserved.



INSPIRATION TO BUILD BETTER