

LYSAGHT® FENCING



DESIGN AND INSTALLATION GUIDE

CYCLONIC



INSPIRATION TO BUILD BETTER

Contents

1.0	INTRODUCING OUR NEW FENCING RANGE	3
2.0	COMPONENTS FOR FENCE ASSEMBLY AND INSTALLATION	4
3.0	AT THE START	6
4.0	FENCE SELECTION	7
5.0	SELECT FENCE POSTS AND CAPS	9
6.0	DETERMINE POST LENGTHS	10
7.0	FOOTINGS	11
8.0	INSTALLING A FENCE: STEP BY STEP	12
9.0	INSTALLING FENCE POSTS	13
10.0	PREPARING RAKED SECTIONS	14
11.0	INSTALLING INFILL SHEETS	15
12.0	FINISHING OFF THE FENCE INSTALLATION	16
13.0	INSTALLING 'PLUS OPTION'	17
14.0	TAPERING ENDS OF FENCES	18
15.0	INSTALLING INFILL STRIPS & POST CAPS	19

This is a step-by-step guide for the selection and installation of LYSAGHT NEETASCREEN® steel fences in cyclonic regions. When this fence is combined with attractive steel lattice, it is called NEETASCREEN PLUS®.

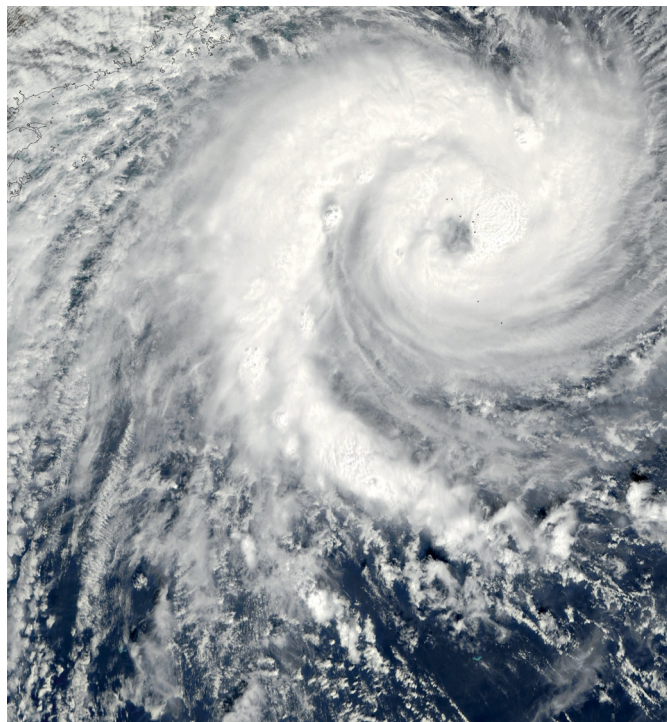

1.0 INTRODUCING OUR NEW FENCING RANGE

THE FACTS BEHIND LYSAGHT® STEEL FENCING

Boundary fences are one of the most visible features of many homes – and also one of the most exposed to the elements. That’s why the fence you choose needs to be attractive, strong and designed to last.

Choose a LYSAGHT® steel fence solution from Lysaght and you can be confident that over 40 years of steel fencing experience will ensure you get a fence that will not only look great when you install it but will give you peace of mind for years to come.

CYCLONIC OPTIONS FOR LYSAGHT® STEEL FENCES

Through an extensive program of wind pressure testing at our own NATA accredited research facility, Lysaght has been able to significantly improve the design of LYSAGHT® fences for cyclonic wind regions C and D. As a result, LYSAGHT® steel fences can now confidently be installed in all regions of Australia.

Northern Territory and Western Australia customers can obtain engineer-certified drawings of these fences based on the engineering principles and installation details provided in this manual. Seek advice from your local LYSAGHT® Technical Representative.

INTRODUCING THE NEW 3 SHEET/PANEL LYSAGHT® FENCING RANGE FOR CYCLONIC REGIONS

LYSAGHT® steel fences in cyclonic regions are now even better looking with the introduction of the 3 infill sheet per panel design. There are fewer posts to interrupt the clean lines of a long run LYSAGHT® steel fence. With fewer post holes to dig, installation can be quicker and even more economical with less concrete footings required.

DESIGNED FOR STYLE

LYSAGHT® steel fences for cyclonic regions are available in two styles and a range of COLORBOND® steel colours to suit every Australian home. Complemented by a range of accessories, such as lattice, you can be confident finding the perfect fence for your home.

Traditional NEETASCREEN® - our first and still our most popular style - is suitable for cyclonic regions.

HEIGHTS FOR EVERY BACKYARD

LYSAGHT® steel fences in cyclonic regions are available in standard heights of 1500 and 1800mm and can be installed on flat and sloping grounds.

BUILT TO LAST

Designed to Australian Standards, fully engineered and wind pressure tested to Australian wind loading standards in our NATA accredited facility, LYSAGHT® steel fences combine a unique post and rail system with hi-tensile 0.35mm BMT steel sheets (or 0.42mm BMT steel sheets for Region D) to produce one of the strongest steel boundary fences on the market.

The deep rail system of a LYSAGHT® fence also gives greater latitude for installation of raked fences on sloping ground.

PROVEN IN AUSTRALIA

Because your LYSAGHT® steel fence is guaranteed to be manufactured using genuine COLORBOND® steel, the only pre-painted steel fencing material with over 40 years of proven performance in Australia’s harsh conditions, you can be assured that your fence will look great for years to come.

BACKED BY A REAL WARRANTY

A LYSAGHT® steel fence gives you real peace of mind. Not only do we offer a material warranty backed by one of Australia’s leading manufacturers - BlueScope, but our comprehensive product testing enables us to offer a 10 year structural fencing warranty for all regions in Australia.

1. The LYSAGHT® 10 Year Fencing Warranty covers the structural integrity of your complete fence system and is your guarantee that your fence will remain standing for years to come; and
2. A separate COLORBOND® steel warranty covers the material used to manufacture your LYSAGHT® steel fence against corrosion to perforation by natural weathering and against paint flake and peel.

* When the fence is installed and maintained according to COLORBOND® steel and LYSAGHT® steel fencing specifications.

For further information on the warranties available for a LYSAGHT® fence and eligibility, visit www.lysaght.com/warranty.

MAKE THE RIGHT CHOICE

The products and instructions in this guide are for LYSAGHT® fence installations in the tropical cyclone regions defined in AS/NZS 1170.2 Structural Design Loads, Part 2; Wind Loads (See map Figure 1.1). Refer to our non-cyclonic fencing guide for use outside cyclonic areas.

FIGURE 1.1:

Wind regions (taken from AS 1170.2:2011).

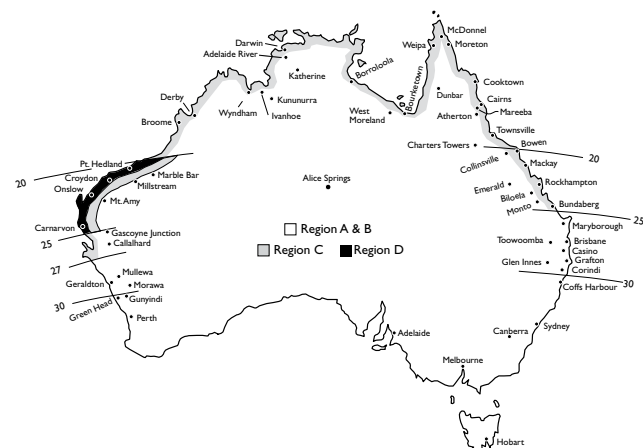

TAKE CARE

LYSAGHT® steel fences are easy to maintain, a simple regular washdown with fresh water is all they need. While your fence will have good resistance to accidental spillage of solvents they should not be installed within one kilometre of marine, severe industrial or other corrosive environments. Similarly both saltwater and freshwater swimming pools contain corrosive chemicals and you should be aware that your warranty does not cover damage resulting from your fence being splashed with contents of the swimming pool. Fences must be installed clear of the ground.

2.0 COMPONENTS FOR FENCE ASSEMBLY AND INSTALLATION

Detailed below is the componentry required for assembly and installation of your new fence panels. Ensure you determine the best option and required components from the following pages prior to placing your order.

FIGURE 2.1:

Components.

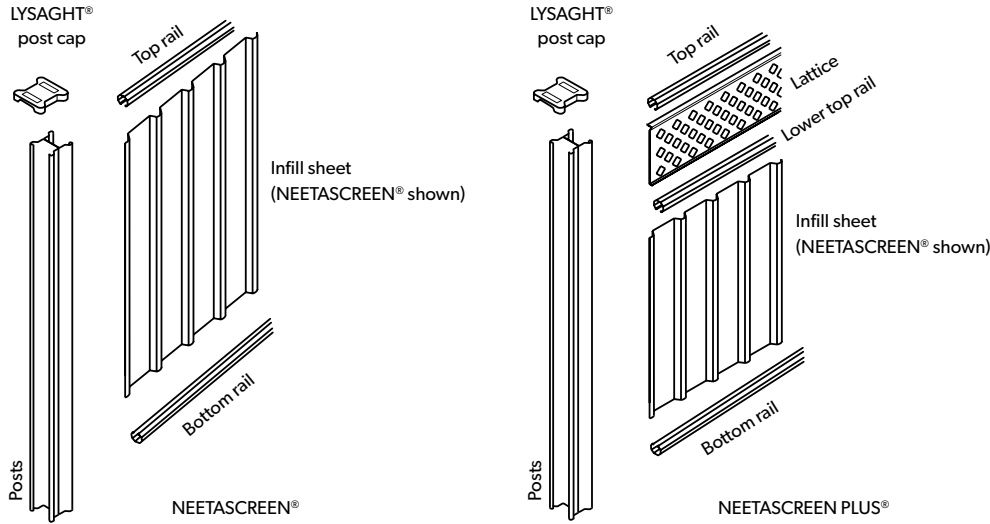

Infill Sheet Styles

Standard lengths: 1490 & 1790mm

Standard lengths for 'PLUS': 1190 & 1490mm

NEETASCREEN® style

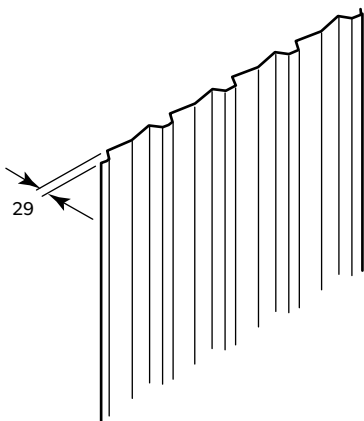

'PLUS' Options

NEETASCREEN PLUS®

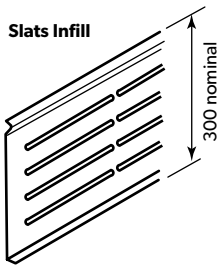

(Available WA only)

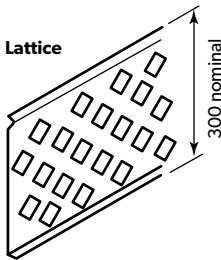

Post Cover Strip

Standard length: 2400mm



Post Caps

LYSAGHT® Post Cap

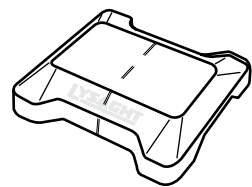

Rails

NEETASCREEN® Universal Rail

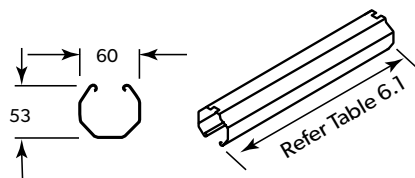

LYSAGHT® Post

Standard Post

Standard lengths:
2100, 2400, 2700 & 3000mm

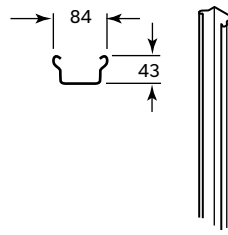

Square (SHS) tubular post

100x100x3.5 SHS (for 1800mm fence)
100x100x2.5 SHS (for 1500mm fence)
Standard lengths: 2400, 3000

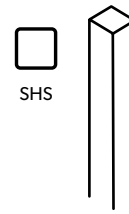

Square (Tubular) Post Cap

(for square post) 60 x 60, 65 x 65

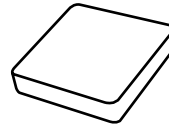

Flat Post Stiffener

(Fence Types FS2 & FS3)

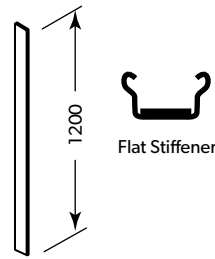

Channel post stiffener

(Fence Types CS2 & CS3)

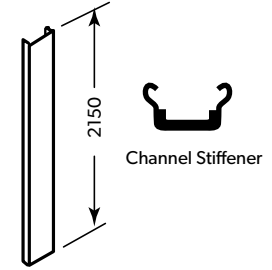

Fasteners

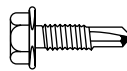

(All fence types)
Self-drilling, self tapping hex.
washer-head screws 10-16x16

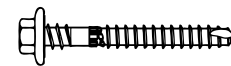

(Fence Type FS3, CS3, SHS3 only)
Self-drilling, self tapping,
long drill bit hex. head screw
12-24 x 32

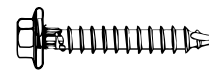

(Fence Type FS3, CS3, SHS3 only)
Self-drilling, self tapping,
hex. head screw 12-14 x 45 or
RoofZips M6-11x50 or
AutoTek M5.5-14x50

3.0 AT THE START

BEFORE YOU ORDER

- Sections 4, 5 & 6 are about selecting the right components in order to get the fence you want. This includes choosing the right fence type, post lengths and infill profile.
- Decide if you prefer NEETASCREEN® or NEETASCREEN PLUS®.
- Decide the height of your fence 1500 or 1800mm high.
- Choose your components as listed in the order guide at right.
- The subsequent pages detail how to install your fence.

BEFORE YOU START WORK

- Read this guide.
- Check you have the correct components for the type of fence you are installing.
- Check where you intend to dig that there are no underground electricity, telephone, gas or water mains.
- Check you have the tools that you need.

TOOLS YOU NEED

- Screw gun (or power drill) with torque adjustment
- Marker, coloured pencils or chalk - not black pencil
- Tape measure
- Rubber mallet
- Stringline and marker pegs
- Shovel and/or spade
- Spirit level
- Safety gloves and glasses
- Sharp knife (to split LYSAGHT® post caps)
- Tin snips (if cutting required)
- Nibbler (optional if cutting required)
- Power saw with metal cutting blade (optional if cutting required)
- Concrete mixer (optional)
- Posthole digger (optional)

COMPONENTS

Fences vary according to the cyclonic wind conditions they must endure. See Table 4.1 for the fence type suitable in your area.

POSTS AND POST CAPS

Each standard fence panel is supplied with two standard posts. However, depending on how you configure corners and ends of fence runs, or Wind and Terrain Categories, you might need extra standard posts or some square (SHS) posts (Figure 5.1).

Your selection of these extra posts will affect the number and type of additional post caps.

ORDER GUIDE

STANDARD COMPONENTS

A standard FS3 fence panel consists of the following components:

NEETASCREEN® FS 3 COMPONENTS

- 2 Standard posts
- 2 flat post stiffeners
- 2 NEETASCREEN® universal rails
- 3 NEETASCREEN® infill sheets
- 1 LYSAGHT® post cap*
- 12 Self-drilling hex. head screws #10-16x16. All cyclonic fences have stitching screws at mid rail and every rib
- 4 Self drilling hex. head #12-24x32 series 500 for flat stiffener to each post
- 13 Self drilling hex. head screws #12-14x45 for infill sheet to each rail (NEETASCREEN®)

NEETASCREEN PLUS® FS 3 COMPONENTS

- 2 Standard posts
- 2 Flat post stiffeners
- 3 NEETASCREEN® universal rails
- 3 NEETASCREEN® infill sheets
- 1 Lattice
- 1 LYSAGHT® post cap*
- 22 Self-drilling hex. head screws #10-16x16
- 4 Self drilling hex. head #12-24x32 series 500 for flat stiffener to each post
- 13 Self drilling hex. head screws #12-14x45 for infill sheet to each rail (NEETASCREEN®)
- 2 Post infill strips (optional)

* You may need to order extra caps depending on your post configurations (Section 5).

CS2 & CS3 fences contain the addition of a channel post stiffener.

All cyclonic area fences have added fasteners to stitch the rails to the infill sheets (Section 12). Non-cyclonic fences are detailed in the Non-cyclonic Fence Design and Installation Guide.

4.0 FENCE SELECTION

In cyclonic areas, it is critical to go through the selection process correctly to ensure you choose the correct fence for the conditions.

First, select whether you are in wind category C or D. (See Figure 1.1 to help you decide or consult your local council).

Second, choose your Terrain Category, using the Terrain Category descriptions and diagrams on this page.

Now consult Table 4.1 to see what types of fences are suitable. The code is explained at the top of Table 4.2.

And finally, select a style from the chart below to ensure the infill panels you want are suitable for your area (Table 4.2).

INSTALLATION ENVIRONMENT

Steel fences should not be installed within 1km of marine, severe industrial or other corrosive environments. Take extreme care if the fence is near a swimming pool because pool water splashed on the fence will void the warranty.

The fence must be installed clear of the ground to ensure longevity.

These fences are not to be used as a retaining wall.

1. DETERMINE YOUR WIND REGION

The information in this guide is suitable for use only in regions C and D of AS/NZS 1170.2 (Figure 1.1). Non-cyclonic regions are covered in our Non-cyclonic fence installation guide. If you have any doubt about the region your fence will be in, get advice from your local building consent authority.

2. DETERMINE YOUR TERRAIN CATEGORY

Select the terrain category that best describes the area in which your fence will be erected from the categories listed at right. Use this information to determine the type of fence required.

If you want to build on the top of a hill, adjacent to an escarpment, on a ridge, or in terrain Category 1, you need engineering advice beyond the scope of this publication.

FIGURE 4.1:
Terrain Categories.



Terrain Category 2

Open terrain including sea coast areas, airfields, sporting fields, grassland with a few well-scattered obstructions, such as isolated trees and uncut grass, having heights generally from 1.5 to 10m, and water surfaces. Typically acreage-suburbia with less than 10 houses per hectare.



Terrain Category 2.5

Terrain with a few trees, isolated obstructions (for example agricultural land, canefields or long grass to 0.6m). This category is typical of developing outer urban areas. Less than 10 houses per hectare; or more than 10 houses per hectare, 500m apart and in two rows.



Terrain Category 3

Terrain with numerous closely spaced obstructions the size of domestic houses 3 to 5m high. Typically residential-suburbia with ten or more houses per hectare.

TABLE 4.1:

Select Cyclonic Fences by Infill Sheets, Wind Region & Terrain Category ('PLUS Option' is not available for Region D).

Nominal Fence Height (mm)	Terrain Category	Wind Regions	
		C	D
		Fence type Infill sheets	Fence type Infill sheets
1500 & 1800	2	FS2, CS3 NS,SS: 0.35mm	CS2, SHS3 NS: 0.42mm
	2.5	FS3 NS,SS: 0.35mm	N/A N/A
	3	FS3 NS,SS: 0.35mm	N/A N/A

FIGURE 4.2:

Fence types and infill styles.

KEY TO FENCE TYPES

There are 3 kinds of suitable fences, defined by the type of posts:

- FS = Flat Post Stiffener
- CS = Channel Post Stiffener
- SHS = Square Hollow Section

Number of infill sheets per panel

Number (2 or 3) = Number of infill sheets per panel.

Choose a style (Use Table 4.1)

Available Fence style is: NEETASCREEN® (NS)

Choose a 'PLUS Option' (if desired, Region C only)

'PLUS Option's are currently only available for Wind Region C.

Choose lattice (or you can also choose slats in W.A.).

Example: Wind Region C, Terrain Category 2.5 means an FS3 fence would be suitable. Select a suitable infill sheet style from Table 4.1.

Therefore, a 1800mm NEETASCREEN® FS3 is a fence with a flat post stiffener and three (3) NEETASCREEN® infill sheets per panel is suitable. No 'PLUS Option' was selected.

Fence Type FS2
(2 infill sheets, flat post stiffener, infills screwed to rails)

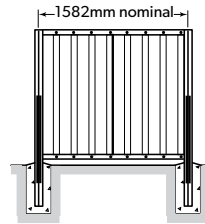

Fence Type CS2
(2 infill sheets, channel post stiffener, infills screwed to rails)

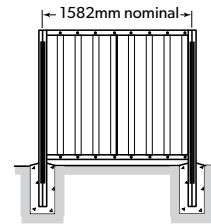

Fence Type FS3
(3 infill sheets, flat post stiffener, infills screwed to rails)

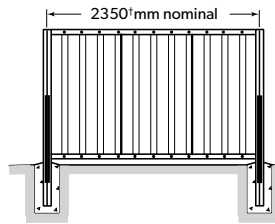

Fence Type CS3
(3 infill sheets, channel post stiffener, infills screwed to rails)

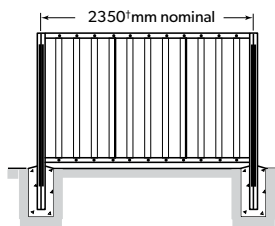

Fence Type SHS3
(3 infill sheets, square hollow section posts, infills screwed to rails)

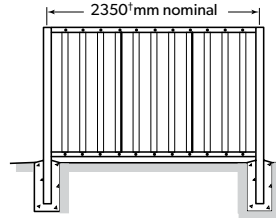

†Rail lengths vary. Refer to Table 6.1.

'PLUS Options'

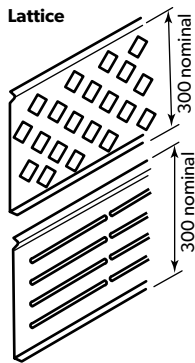
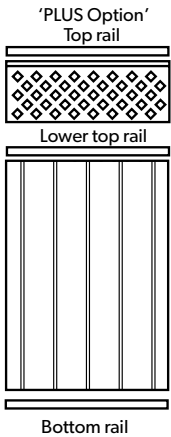

Slats
(Available WA only)

Infill Sheets

Standard lengths 1490, 1790 mm
Standard lengths for 'PLUS' 1190, 1490 mm

NEETASCREEN® style

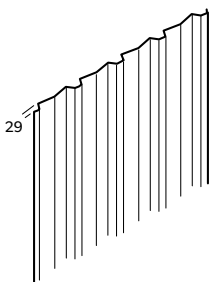

5.0 SELECT FENCE POSTS AND CAPS

SELECTION OF POSTS

Check the number and type of posts you will need, starting with a sketch of your fence site. Mark on it the type of posts you will need (Figure 5.1).

You will need to consider:

- If the fence will be 2 or 3 infill sheets for each panel
- Posts in a fence run that don't form a corner (typically at the front of a property next to road);
- Intermediate posts (they are always two standard LYSAGHT® posts screwed back-to-back);
- The various configurations of posts at corners;
- If the fence is to be stepped;
- If the ends of the fence are to be tapered (Section 14);
- Gate posts are suitable (RHS/SHS).

SELECTION OF POST CAPS

Fix post caps on all fence posts to give the perfect finishing touch and to protect against any sharp edges. (Section 15) Choose your post caps based on your post configurations and personal preference.

LYSAGHT® Post Caps fit two standard LYSAGHT® posts screwed back-to-back. For a single standard post, it is easy to cut a cap in half with a sharp knife in the groove moulded into the underside—trim the edges straight.

Square Post Caps suit square posts and are usually used at corner junctions and gate openings.

FIGURE 5.1:

Preliminary selection of posts.

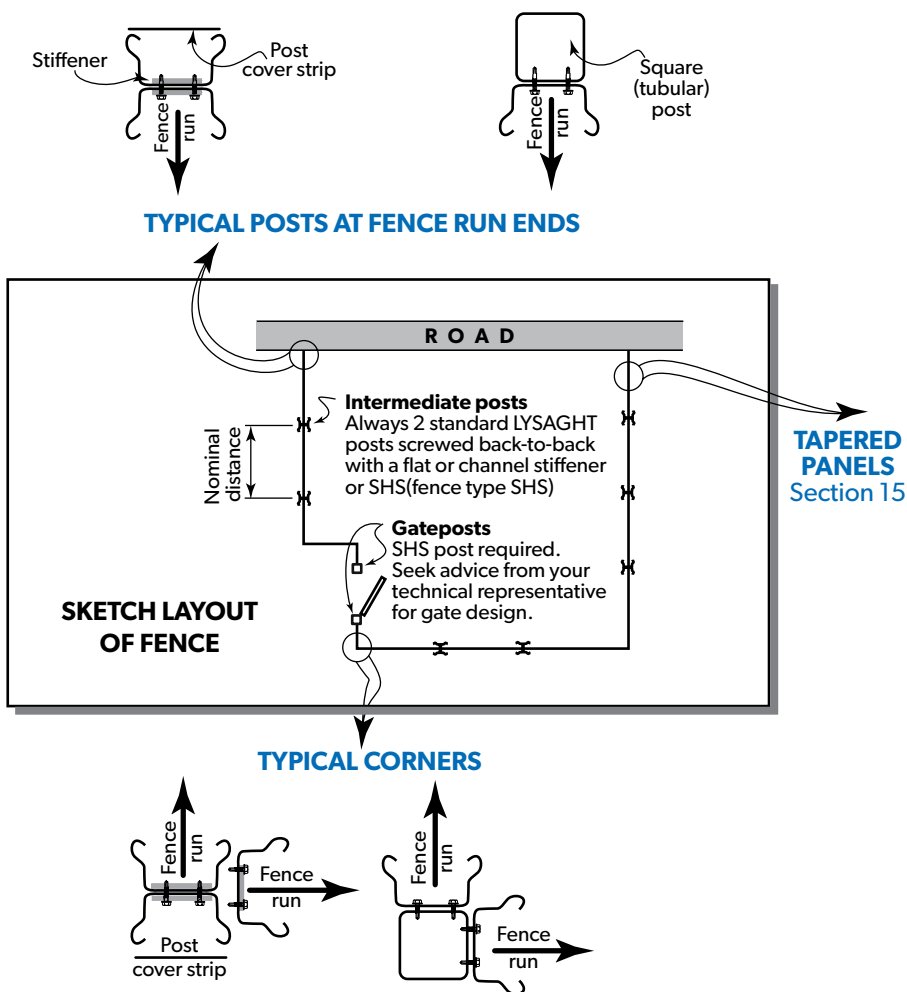

6.0 DETERMINE POST LENGTHS

FIGURE 6.1:

Fence installations.

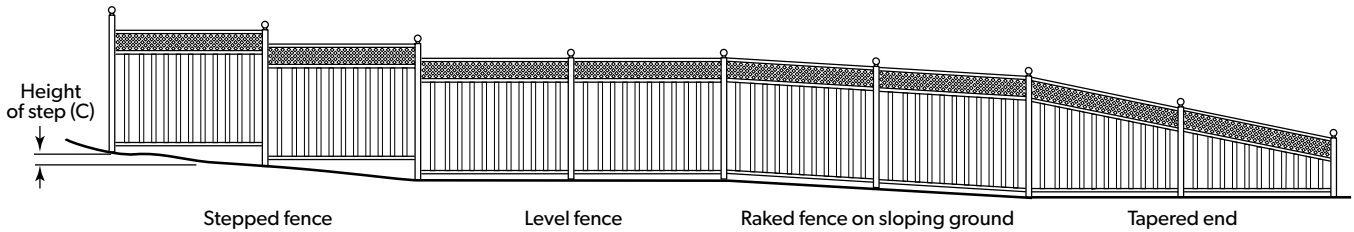

If the ground is not all level, consider whether the fence will be stepped or raked (Figure 6.1). For aesthetic reasons, people often choose to step rather than to rake when using a lattice.

Fences may be installed raked on slopes of 1 in 20 without cutting components to fit. Refer to Table 10.1 for lengths.

For steeper slopes you will need to:

- step your fence; or
- cut the infill sheets, lattices and rails (Section 10).

If some of the ground is level and some sloping, or if the slope varies markedly, you might need posts of different lengths.

DETERMINE BASIC POST LENGTHS (3 INFILL SHEETS/ PANEL FENCES)

Refer to Table 6.2. For data on tapered ends (Section 14).

Basic post length = (Footing depth – 40) + (Height above ground) (NOTE: Cyclonic fences must not exceed 1800mm).

Get the footing depth from Section 7 and height above ground from:

$$\text{Height of post above ground} = A + B + C$$

Where:

A = Nominal fence height (Figure 6.2).

B = 50mm ground clearance (Figure 6.2).

C = If a stepped installation: height of the step (Figure 6.1).

SELECT STANDARD LENGTHS

Use the table below to select the lengths you need to order. The standard lengths are 2100, 2400 and 2700mm.

TABLE 6.1:

Panel width.

	3 Infills	2 Infills
NEETASCREEN®	2350	1582

TABLE 6.2:

Length of posts.

Calculated basic post length		Length of standard post to use (mm)
Minimum (mm)	Maximum (mm)	
2100	2210	2100
2211	2399	2400*
2400	2510	2400
2511	2699	2700*
2700	2810	2700
2811	2999	3000*
3000	3110	3000

*Cut so that dimension E in Figure 6.2 is between 40 and 150mm.

* 3000mm posts are subject to enquiry.

FIGURE 6.2:

Panel arrangement (NEETASCREEN® shown).

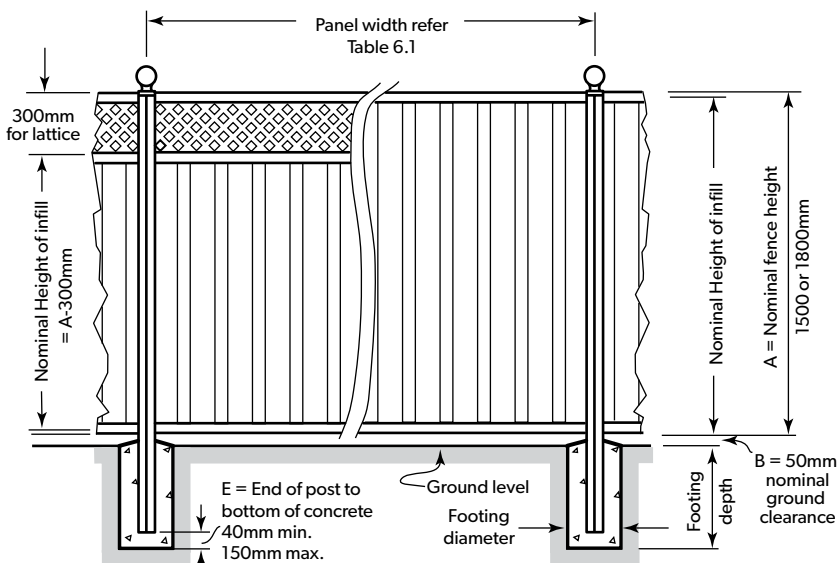

7.0 FOOTINGS

SELECT YOUR MINIMUM FOOTING DEPTH

Your fence posts must be embedded in concrete footings of adequate size. All footings in Table 7.1 are 250mm diameter.

DEPTH OF FOOTINGS

Table 7.1:

Footings depth for fencing by wind region (mm).

Nominal Fence Height	Wind Region	Terrain Category	Soft Clay, Loose Sand		Medium Dense Sand & Gravel, Stiff Clay		Rock	
			Fence length (panels)		Fence length (panels)		Fence length (panels)	
			2	3	2	3	2	3
1500 & 1800mm	C	2	900	1100	500	700	300	400
		2.5	700	900	400	600	300	400
		3	500	700	300	400	200	300
	D	2	1100	1500	700	900	400	600
		2.5	-	-	-	-	-	-
		3	-	-	-	-	-	-

Footing depth = mm for 1800mm fence height
 Footing diameter = 250mm for Regions C and D.

EXAMPLE

Givens

1. Site in a Mackay built-up suburb.
2. Wind region: Region C
3. Terrain category: Established residential area – Terrain Category 3
4. Soil type: Soft clay
5. Fence height: 1800mm

Solution

Fence Type FS3 may be used at this site (Section 4)
 Footing required is: 250mm diameter x 700mm deep

Soil around posts footings shall be compacted as necessary to achieve minimum allowable bearing capacity:

- Soft clay, loose sand = 100kPa
- Medium dense sand and gravel, stiff clay = 200kPa
- Rock = 400kPa

FIGURE 7.1:

Footing dimensions.

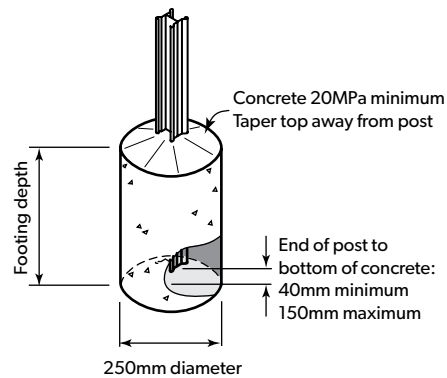
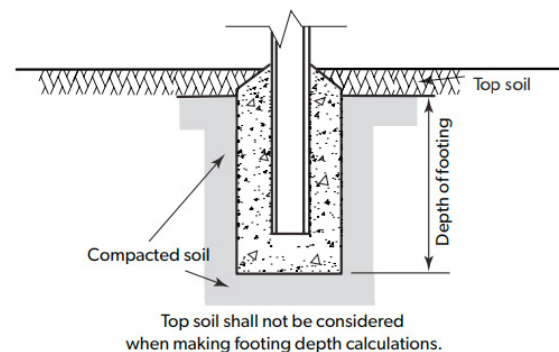

FIGURE 7.2:

Calculating footing depth.



8.0 INSTALLING A FENCE: STEP BY STEP

So far we have talked about selecting your fence. The following section discusses step by step, how to prepare and install your LYSAGHT® fence.

WHAT KIND OF SITE DO YOU HAVE?

Work out your levels. Is it one straight run, or are there raked or stepped sections?

MAKING UP POSTS

Start by making up posts by screwing them together. Screwing the posts together requires seven staggered screws. (Figure 8.1).

As a tip, bring your top screw down so it sits below your top rail. Otherwise your top rail is going to get stuck on it every time you go to fit it in. (Figure 8.1.)

Tip: Use 'G' clamps to hold stiffeners and post in place.

Make up the required number of posts. For Fence Type FS2, FS3, CS2 and CS3, post stiffeners must be fitted (Figure 8.1).

FS = Flat stiffener, CS = Channel stiffener.

If using stiffeners, screw into place while making up posts.

FIGURE 8.1:

Fastening posts together.

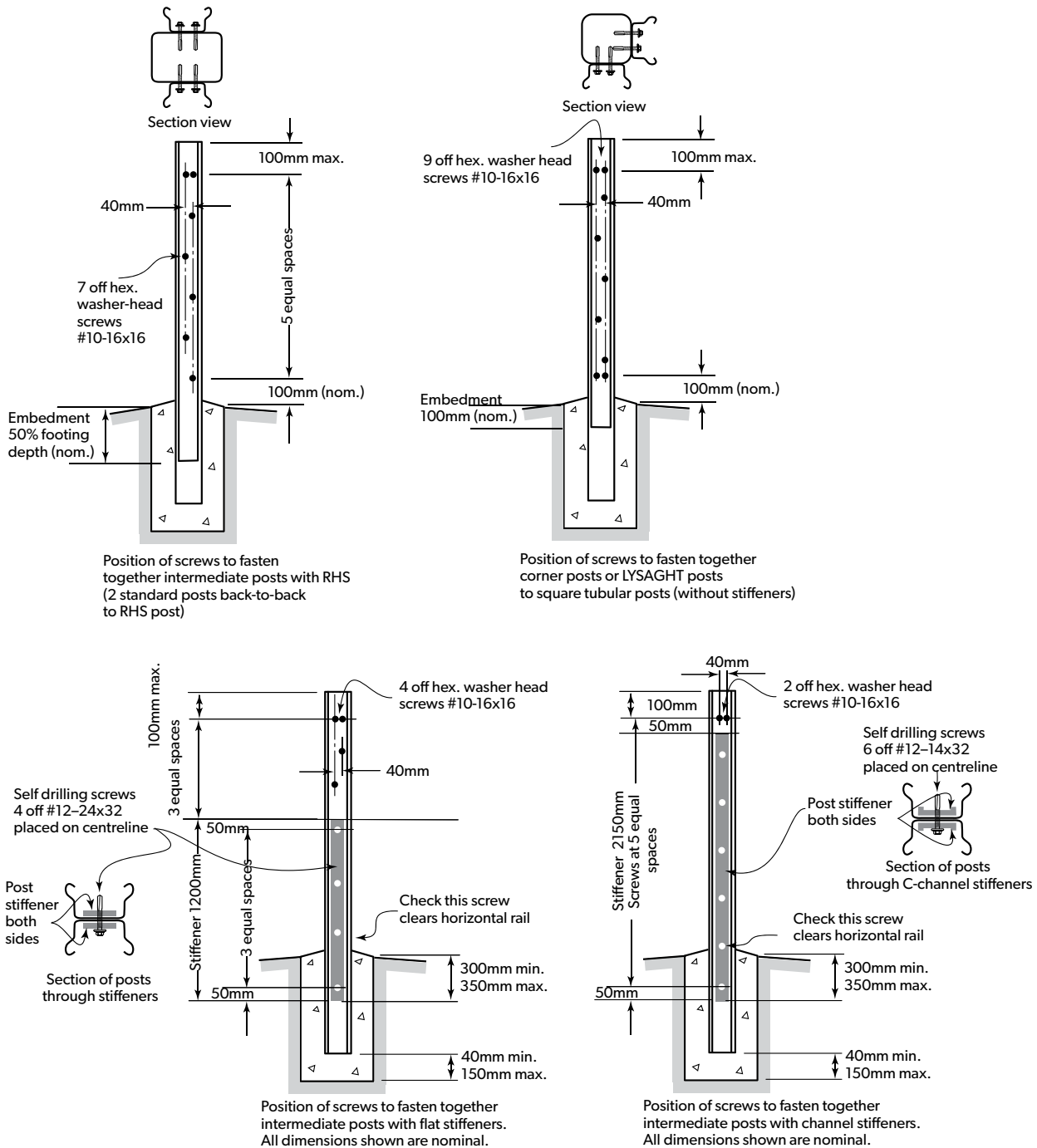

NOTE: Details shown above are for 1800mm fence height. Contact your local sales representative for 1500mm fence height.

9.0 INSTALLING FENCE POSTS

FIGURE 9.1:

Stringline layout.

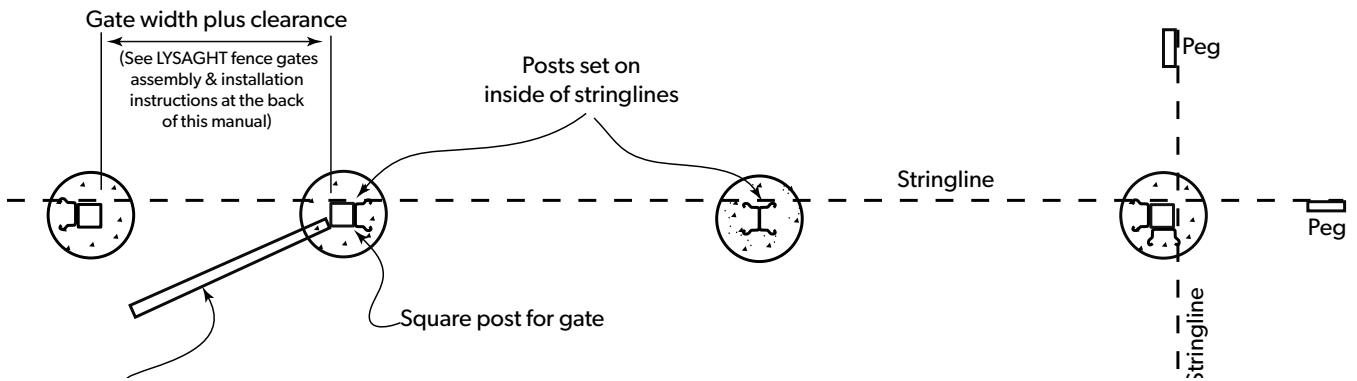

1. LAYOUT STRINGLINES TO POSITION YOUR FENCE

Stringlines mark the outside line of your fence posts (Figure 9.1), and help to set your fence posts at a uniform height.

Determine the exact location of your fence and setup a stringline. Keep the stringline taut and set at the top of two end posts. Place the stakes 500mm beyond the corners of the fence, so as not to obstruct the holes.

2. LAYOUT POSTS AND DIG HOLES

Mark the position of fence posts. Lay the rails on the ground butting end to end between the two end posts so you can see exactly where your posts are going to go. For raked sites, longer rails may need to be used. Refer to the raked section on page 14 and Table 10.1.

If there is to be a gate, seek advice from a suitably qualified engineer or consult your technical sales representative for design advice.

A fence panel can be reduced from the nominal width, without cutting infill sheets, by the increments shown in Figure 12.2. Rails and lattices must be cut to suit a narrow fence panel.

Dig the holes using the hole sizes determined from Section 7.

3. PLACE THE FIRST POST

If the ground slopes, start at the high end.

Lay a minimum of 40mm concrete under the end of the post and set your post into the hole. This should be done for every post. Fill the hole with concrete and use your spirit level to get the post plumb. Tamp the concrete down. Ensure that the concrete tapers away from the post. (Figure 7.1). Be careful that concrete doesn't contact the rails above ground.

FIGURE 9.2:

Placing remaining posts.

4. PLACE REMAINING POSTS

Place the second post in its hole and engage a bottom rail with the first and second post. Make sure the bottom rail is 50mm above the ground.

A tip is to give the rails a squeeze when you're putting them into or out of your post. This helps prevent scratching.

Fasten the bottom rail with one hex. head screw (#10-16x16) from both sides of each post.

Use the stringline to ensure your posts are all the correct height, plumb and in line, before concreting into position.

Wait at least 24 hours for the concrete to dry before installing infill sheets.

Continue installation of posts and bottom rails for the remainder of the run.

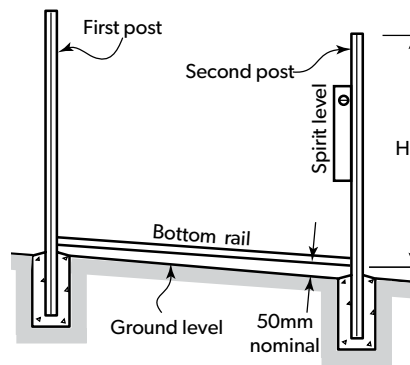

MIXING YOUR CONCRETE

Thoroughly mix ingredients: 3 parts 20mm blue metal; 2.5 parts sand; 1 part cement. Add water and mix well before use. Premixed concrete (20MPa min.) may also be used.



Use stringline to set post heights.



Lay the rails along the string line to determine positions of posts.

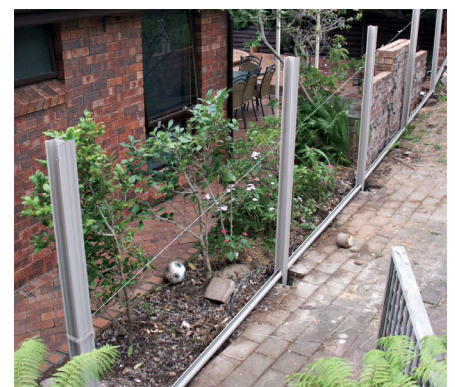

Set all the bottom rails into position ensuring a 50mm ground clearance. PAGE 13
LYSAGHT® FENCING - CYCLONIC

10.0 PREPARING RAKED SECTIONS

If your fence requires raked sections, you may need to prepare the rails and infill sheets. If your fence is level or stepped, skip ahead to the infill installation instructions.

PREPARING RAILS

For small rakes, the increase in the length of top and bottom rails can be ignored. An approximate length of raked rail is shown in Table 10.1. A longer rail and a 'PLUS Option' are available for this purpose.

The length to cut these raked sections is detailed in the table at right, once you have determined the height of the cut.

FIGURE 10.1:

Cutting infill sheets for a raked fence (Refer to Section 6 for calculation. - Fence type RHS3 shown).

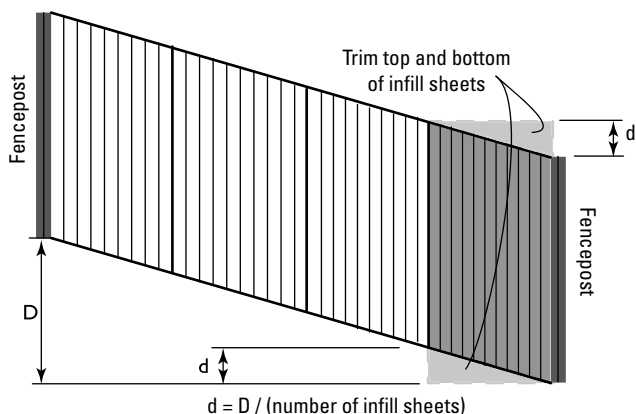

PREPARING INFILL SHEETS

Work out the measure of the cut by resting your spirit level inside the rail (at least the width of a sheet) at the high end of the rail (Refer photo). Measure the width of a sheet, and measure the distance with your tape between the bottom of the level and the inside of the rail. That will show you the angle of your cut. Wherever possible, make the rake on the bottom rail the same as the top.

Measure the height of your fence up from your cut edge and cut at the same angle at the top of the sheet.

Use a coloured pencil, marker or chalk to mark the cut, as a pencil may cause corrosion.

Fine tune rails before screwing them into position.

Ensuring the rails are aligned, and the sheets are neat vastly improves the appearance of your fence.

Once you have installed all the bays, stand back from the fence and have a look at the fence as a whole.

Make sure the lines on your sheets run parallel to your posts. Make sure the joint of the overlap looks flush, without a big gap. Adjust where required.

Screw the rails into position.

Remove any swarf from the installation.

TABLE 10.1:

Measurements for a raked fence.

(3 Infill Sheets/Panel) Fence Types

Raked Rail Length Approx.	Infill Sheet Cut (d)		
	Height of Step	NS (mm)	NS (mm)
0	2350	-	
150	2354	50	
250	2363	83	
300	2369	100	
350	2375	117	
400	2383	117	

(2 Infill Sheets/Panel) Fence Types

Raked Rail Length Approx.	Infill Sheet Cut (d)		
	Height of Step	NS (mm)	NS (mm)
0	1582	-	
150	1589	75	
250	1602	125	
300	1610	150	
350	1620	175	
400	1632	200	

NS = NEETASCREEN®
Measurements in mm.



Measure the fall on the rail. This will allow you to position the top rail parallel and also to correctly cut the infill sheets.



Measure the amount to be cut and mark the sheet. Ensure you measure edge to edge, not rib to rib.



Cut the infill sheets two or three at a time. This equals a single bay and ensures uniformity. Measure twice, cut once.

11.0 INSTALLING INFILL SHEETS

Installing the infill sheets is where the art is in fencing. It requires getting a few things to line up all at the same time. It's preferable to treat this as a one person job. Two people get in each other's way.

The following steps assume a standard fence style, however the steps are similarly applied to a 'PLUS' fence option. For the installation of the lattice for a 'PLUS Option' style, refer to Section 13.

Start at the high side. Insert the first sheet flush into the bottom rail, usually about 200mm out from the post. Lift the top rail and slowly slide the sheet into the top rail. Using your knee near the bottom of the sheet and your hand near the top, slowly ease the first sheet along the rails until they contact the post. Remember to move the sheet square or it might kick out of one of the rails.

When the second infill sheet (in a three panel fence) is placed, make sure you place the sheet to allow for the overlap (Figure 12.2). At this stage some minor adjustments may be necessary to get the lap to sit correctly or to fit the sheet into the rail. Gently bump the fence sheet into position as required.

The last sheet is the most difficult, only because there are a few things to get right. Place the bottom of the sheet into the rail, ensuring there is overlap to the previous sheet.

It is usually necessary to gently bump, and push this final sheet into position. Roll the top rail away from you and this will assist feeding the top of the sheet into the rail channel. Get the side facing away from you in the bottom rail and then you can push the ridges of the side facing towards you into position with both the rail and the post. Once the sheet is in position, gently tap the top rail down onto the sheets using the heel of your gloved hand.

Do not screw off the top rail until you have 'fine-tuned' the rails by standing back and looking at the whole of the fence. This allows you to make minor adjustments to get the rails aligned.



Lift top rail and place 1st sheet into bottom rail. Slide to end position.



Lifting top rail helps ease 1st sheet into end position.

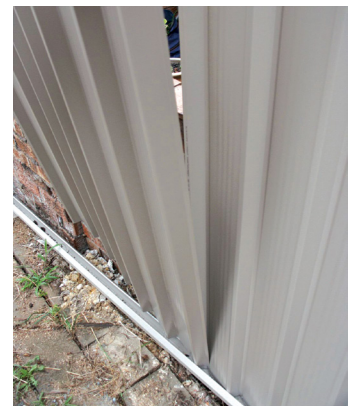

Place 2nd sheet into bottom rail, ensuring there is sufficient overlap.



Position last sheet. Gentle force can be used.



Lift top rail and rotate until infill sheet slides into rail. Tap top rail down into position.

12.0 FINISHING OFF THE FENCE INSTALLATION

ALIGN AND FINE TUNE RAILS BEFORE SCREWING THEM INTO POSITION

Do not screw off the rail yet.

Ensuring the rails are aligned, and the sheets are neat vastly improves the appearance of your fence.

Once you have installed all the bays, stand back from the fence and have a look at the fence as a whole.

Make sure the lines on your sheets run parallel to your posts. Make sure the joint of the overlap looks flush, without a big gap. Adjust where required.

Once you have made these adjustments, screw the rails into position. (Figure 12.3) Screws are required top and bottom on all cyclonic fences at every rib. (Figure 12.1).

Remember to wipe off the fence to remove any swarf from the installation.



Screw off top rail and make it as close to parallel with the bottom rail as possible. Stand back and look at your work as you go along.

FIXING INFILL SHEETS TO RAILS FOR CYCLONIC FENCES

From one side, fasten infill sheets to both top and bottom rails with screws at every rib; the screws must penetrate the rails and both infill sheets.

FIGURE 12.1:

Fixing infill sheet to rail on cyclonic fence.

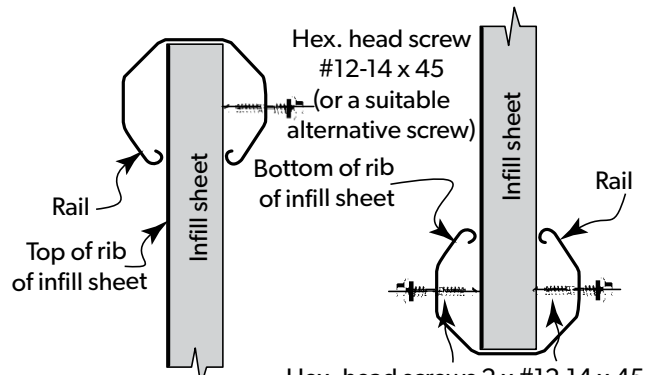

FIGURE 12.2:

Sheet overlaps.

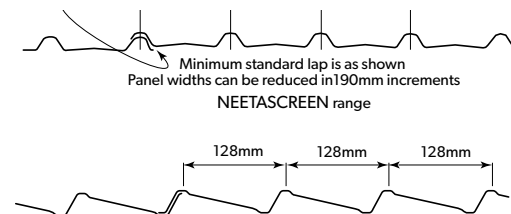
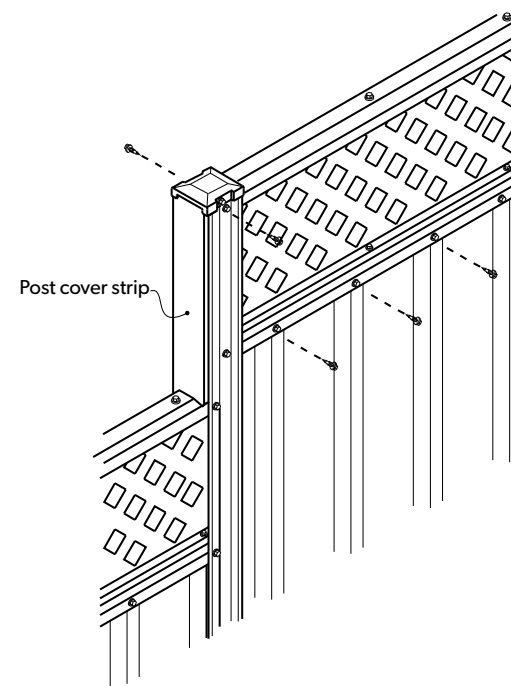

FIGURE 12.3:

Install infill sheets.



13.0 INSTALLING 'PLUS OPTION'

INSERTING THE LATTICE OR SLATS

Engage a top rail onto the top of a lattice or slats (Figure 13.2 for correct orientation).

Lower the rail and lattice or slats onto the top of a fence panel, engaging the ends of the rail with the posts (Figure 13.1).

Fix with three screws (#10-16x16) along the bottom flange of the lattice or slats (Figure 13.2). Protect the paintwork with a piece of cardboard between the drill and the lattice.

Fix the top rail to the lattice or slats with three screws (Figure 13.2).

Fasten the top rail to the posts with one hex. head screw (#10-16x16) on both sides of each post.

A component (Edge cover strips used for gates) is available to cover edges of the lattice or slats if it is trimmed in length.

FIGURE 13.1:

- 1 Rail installation at top of infill panel
- 2 Installation of lattice

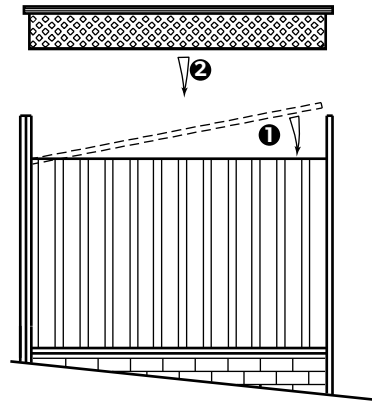
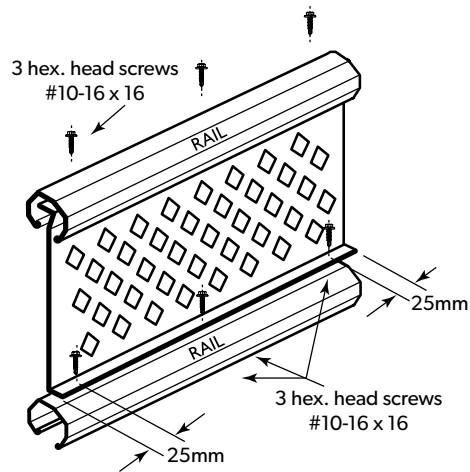

FIGURE 13.2:

Fastening of lattice. (NEETASCREEN® rails shown)



14.0 TAPERING ENDS OF FENCES

At the end of a fence run, where the fence doesn't form a corner (sometimes called a free end), the panels experience increased wind loadings—particularly where your fence extends beyond the alignment of your house.

In all cyclonic areas, your fence must be tapered in height over the last two panels (Figure 14.1).

Cut the top of the infill sheets in a manner similar to that shown for a raked fence (Figure 14.1).

A longer rail and a lattice are available for this purpose.

FIGURE 14.1:

Tapering ends of fences over two panels.

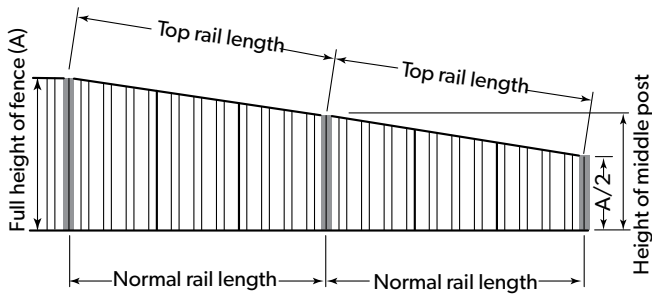

TABLE 14.1:

Tapering ends of fences.

3 Infill Sheets/Panel

Fence Style	Half Fence Height	Height of Middle Post	Normal Rail Length	Top Rail Length
1500 NEETASCREEN®	750	1125	2350	2380
1800 NEETASCREEN®	900	1350	2350	2393

2 Infill Sheets/Panel

Fence Style	Half Fence Height	Height of Middle Post	Normal Rail Length	Top Rail Length
1500 NEETASCREEN®	750	1125	1582	1626
1800 NEETASCREEN®	900	1350	1582	1645

15. INSTALLING INFILL STRIPS AND POST CAPS

POST COVER STRIPS

Cover strips are used to complete the open side of two standard LYSAGHT® posts screwed back-to-back (Figure 15.4).

Cut the strips to an appropriate length and slide vertically in place. Some posts require a strip for the full length of the post. Short pieces are needed on stepped fences (Figure 15.4).

POST CAPS

All post caps must be positively secured to your fence with either neutral cure silicone sealant or hex. head screws (Figure 15.3).

For a single standard post, it is easy to cut a cap in half with a sharp knife in the groove moulded into the underside — trim the edges straight. (Figure 15.2).

FIGURE 15.1:
LYSAGHT® Post Cap.

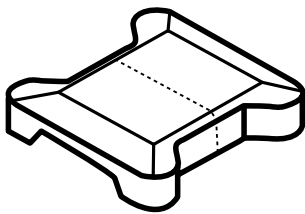

FIGURE 15.2:
NEETASCREEN® (& 'PLUS')
using universal rail.

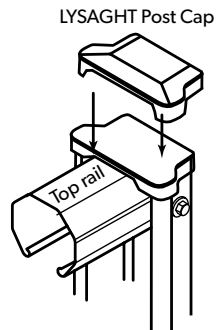

FIGURE 15.3:
LYSAGHT® Post Cap.

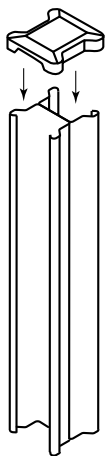
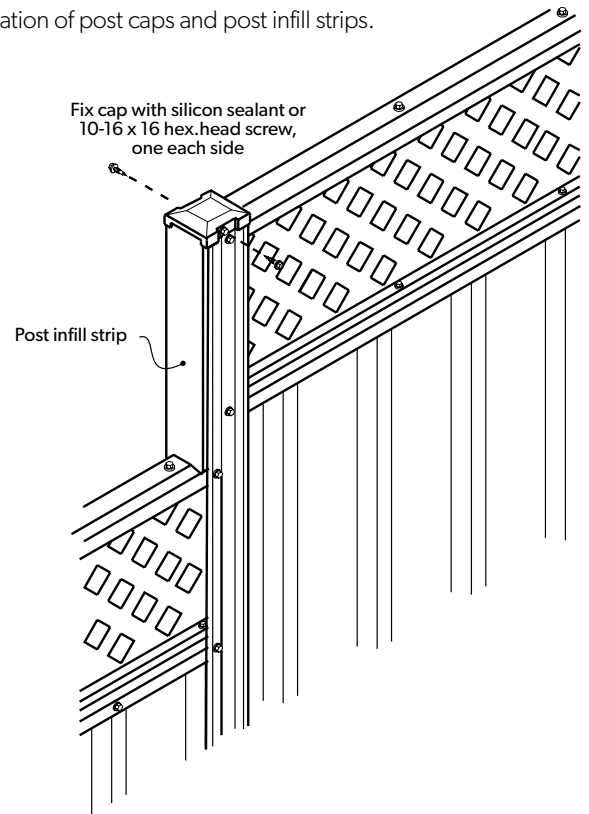

FIGURE 15.4:
Installation of post caps and post infill strips.



PRODUCT DESCRIPTIONS

All descriptions, specifications, illustrations, drawings, data, dimensions, and weights contained in this publication and websites containing information from Lysaght are approximations only. They are intended by Lysaght to be a general description for information and identification purposes and do not create a sale by description. Lysaght reserves the right at any time to:

- (a) Supply goods with such minor modifications from its drawings and specifications as it sees fit, and
- b) Alter specifications shown in its publications and websites to reflect changes made after the date of publication.

DISCLAIMER, WARRANTIES AND LIMITATION OF LIABILITY

- This publication is intended to be an aid for all trades and professionals involved with specifying and installing LYSAGHT® products and not be a substitute for professional judgement.
- Terms and conditions of sale are available at lysaght.com/content/terms-conditions-sale
- Except to the extent to which liability may not lawfully be excluded or limited, BlueScope Steel Limited will not be under or incur any liability to you for any direct or indirect loss or damage (including, without limitation, consequential loss or damage such as loss of profit or anticipated profit, loss of use, damage to goodwill and loss due to delay) however caused (including, without limitation, breach of contract, negligence and/or breach of statute), which you may suffer or incur in connection with this publication.

AUSTRALIAN STANDARDS

Australian Standard	Definition
AS/NZS 1170.2:2021	Structural design actions, Part 2: Wind actions

LYT0041 - 01/2024

FOR DETAILED PRODUCT INFORMATION,
MANUALS AND PROJECT CASE STUDIES VISIT:

[WWW.LYSAGHT.COM](https://www.lysaght.com)

COLORBOND®, LYSAGHT® and ® product names are registered trademarks of BlueScope Steel Limited and ™ product names are trademarks of BlueScope Steel Limited. © 2023 BlueScope Steel Limited. ABN 16 000 011 058. All rights reserved.

INSPIRATION TO BUILD BETTER

