

LYSAGHT® PURLINS



ZEDS AND CEES
DESIGN AND INSTALLATION GUIDE



INSPIRATION TO BUILD BETTER

Contents

1.0	General Data	
1.1	Limit State Capacity Tables & Product Information	4
2.0	LYSAGHT® Zed & Cee Sections	
2.1	General Data for LYSAGHT® Zed & Cee Sections	5
2.2	Zed & Cee Sections - Dimensions and Properties	7
2.3	Section Properties	8
3.0	HOOK-LOK® II Bridging System	9
3.1	HOOK-LOK® II Bridging Installation	11
4.0	LYSAGHT® Series 300 & 350 Bridging System	12
5.0	Purlin & Girt Accessories	13
6.0	Typical Assemblies	14
6.1	Using Purlin & Girt Accessories	14
6.2	Typical Assemblies - Zeds	15
6.3	Typical Assemblies - Cees	16
7.0	Holes & Cleats	17
8.0	Design Notes for Capacity Tables	19
9.0	Limit State Capacity Tables	22
	Single Spans	22
	Double Continuous Spans	28
	Double Lapped Spans	32
	Three Continuous Spans	40
	Three Lapped Spans	43
	Four Continuous Spans	53
	Four Lapped Spans	54
	Cantilever Spans	62

LYSAGHT® ZEDS & CEES FOR PURLINS & GIRTS

LYSAGHT® Zeds and Cees are used in commercial and domestic applications because they are the economical, lightweight alternative to timber purlins and girts. They are quick and easy to install using standard metal fasteners. Zeds can be lapped, eliminating the time-consuming process of cutting to length and consistent straightness simplifies alignment.

PURLINS WARRANTY

Lysaght has always had the most comprehensive product warranties on the market that cover not only the corrosion performance of the material but also the structural and serviceability performance of a wide range of products. Lysaght can back their products with over 150 years experience and credibility. The Lysaght brand is widely recognised as setting the benchmark on quality products, and is trusted and respected by our customers and competitors nationwide.

Warranty protection is available on the range of LYSAGHT® Zed and Cee profiles. This warranty complements the warranties available for the LYSAGHT® roof and wall cladding profiles that are commonly fixed to the purlins.

Application for a warranty must be lodged on our 'Lysaght Request For Warranty' form, available by contacting the nearest Lysaght Service Centre. The warranty is available subject to application and project size.

Additional warranty periods with additional coating treatments are available subject to enquiry.



1.0 General Data

1.1 LIMIT STATE CAPACITY TABLES & PRODUCT INFORMATION

BACKGROUND

Pursuing the commitment of Lysaght to constant improvement, this edition of LYSAGHT® Zeds and Cees Users Guide reflects the move to limit state design principles.

Since 1987, in conjunction with the University of Sydney, we have intensively researched the behaviour of purlin and girt systems using the vacuum test rig at the University, which is the only one of its type in Australia and the largest in the world. In our NATA-registered laboratory we have tested full-scale purlin and girt systems on single, double and lapped continuous configurations for both inward and outward loading.

It has been possible to gain a sound understanding of their behaviour. This knowledge allows us to remain at the forefront of technology, in Australia and overseas.

Since the last edition of this manual, the results of this research has been used in the development of AS/NZS 4600.

LYSAGHT® PRODUCTS DETAILED IN THIS MANUAL

Product	Use	Code Prefix
LYSAGHT® Zeds	General purpose purlins and girts	Z
LYSAGHT® Cees	General purpose purlins and girts	C
HOOK-LOK® II Bridging	Flexible bridging system for bracing Zeds and Cees	H2
Series 300 & 350 Bridging	Bridging system for larger spans and greater loads	

This manual incorporates the traditional range of LYSAGHT® purlins and girts in a much wider range of spanning and bridging configurations than before.

The data is intended for specifiers, engineers, builders and erectors for the specification, detailing and erection of LYSAGHT® purlin and girt systems. Included are details of material specifications, dimensions, packing, storage, holes, and bridging location; together with limit state capacity tables.

PRODUCT CODING

A prefix letter for the section shape, and a number indicating the section depth in millimetres designates profiles. For example Z250, or C250; or, where reference is made to both sections of a given size, Z/C250.

NOTE: Not all purlins are available in all States. Some specifications may vary slightly from region to region.

2.0 LYSAGHT® Zed & Cee Sections

2.1 GENERAL DATA FOR LYSAGHT® ZED AND CEE SECTIONS

LYSAGHT® Zed and Cee sections are accurately roll-formed from high-strength zinc-coated steel to provide an efficient, lightweight, economical roofing and cladding support system for framed structures.

The system, which includes HOOK-LOK® II bridging, Series 300 and 350 bridging, and a comprehensive range of accessories, is supplied ready for erection.

APPLICATIONS

LYSAGHT® Zed sections may be used over single spans, lapped continuous and unlapped continuous spans in multi-bay buildings. Lapped continuous spans result in a considerable capacity increase in the system.

LYSAGHT® Cee sections may be used in single spans and unlapped continuous spans in multi-bay buildings. Cee sections are ideal as eave purlins or where compact sections are required for detailing. Cee sections cannot be lapped.

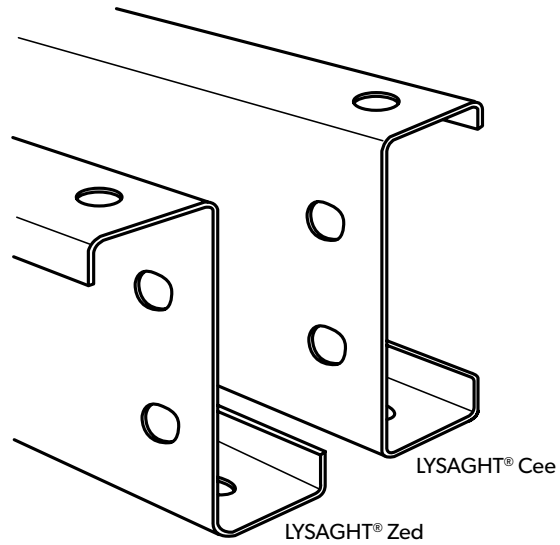

RANGE OF PRODUCTS & SERVICES

Our wide range includes:

- A full range of LYSAGHT® Zeds and Cees;
- A selected range of LYSAGHT® Zeds and Cees with downturned-lip;
- Section sizes from 100mm to 350mm;
- HOOK-LOK® II bridging systems;
- Bolting systems to suit project needs;
- The Lysaght Corrosion Warranty;
- Advice on improving the life expectancy of purlin systems in corrosive environments;
- Access to a national network of experienced engineers.

PERFORMANCE

In accordance with the provisions of AS/NZS 4600, load capacities have been calculated for LYSAGHT® sections using approved LYSAGHT® bridging systems, bolting and other accessories.

Sections chosen using the data provided in the tables will perform as specified when the design, fabrication and erection are carried out in accordance with Lysaght recommendations and accepted building practice.

NON-STANDARD SECTIONS

We can supply a wide range of non-standard sizes (up to 350mm) and shapes, including Cees and Zeds with downturned lip – the Zeds can also be made to lap. Non-standard sections are not stocked in every region.

STANDARD RANGE OF LYSAGHT® ZED & CEES

Nominal Section Size (mm)	BMT (mm)
100	1.0, 1.2, 1.5, 1.9
150	1.2, 1.5, 1.9, 2.4
200	1.5, 1.9, 2.4
250	1.9, 2.4
300	2.4, 3.0
350	3.0

CORROSION WARRANTY

LYSAGHT® purlins and girts are manufactured from GALVSPAN® steel. Subject to design, location and intended use, they are covered by the Corrosion Warranty.

CORROSION PROTECTION & MATERIAL COMPATIBILITY

Some building materials and environmental conditions can be detrimental to coated steel products. These include contact with or exposure to run-off from:

- industrial, agricultural, marine or other aggressive atmospheric conditions;
- incompatible metals, like lead or copper;
- building materials subject to cycles of dryness and wetness, or which have excessive moisture content such as improperly seasoned timber.
- materials which have been treated with preservatives, like CCA or tanalith-treated timber.

A zinc coating of Z350 (350 g/m² minimum coating mass) is the standard coating class provided with LYSAGHT® Zed and Cee sections. This will provide a long and trouble-free life for enclosed buildings and open-sided rural buildings, in a non-aggressive environment.

A non-aggressive environment is 1000m from rough surf, 750m from industrial emission and fossil fuel combustion, and 300m from calm salt waters. Consideration must be given to the nature of activities performed within the building.

For more severe corrosive environments a Z450 (450 g/m² minimum coating mass) will be required. This heavier coating mass will be available in special circumstances and is subject to a minimum order quantity and extended lead times.

Direct contact of incompatible materials with the coating must be avoided.

In such applications, and in very corrosive environments, suitable paint systems can be obtained from paint manufacturers: you can seek advice from our Information Line.

In applications where particular attention is required for corrosion, or the buildup of substances like dust or grain, then consideration should be given to the shape of the sections (either Zed, or Cee, or Zed with downturned lip); orientation of the sections; and coating class. Further information is available from your nearest Lysaght Service Centre.

BOLT SPECIFICATION

LYSAGHT® purlin bolts and nuts have an integrated washer.

Tighten all bolts to 55 Nm torque.

Nominal section size (mm)	Bolt specification
100, 150, 200, 250	M12 LYSAGHT® purlin bolt: standard (grade 4.6) or high strength (grade 8.8)
300, 350	M16 LYSAGHT® purlin bolt: standard (grade 4.6) or high strength (grade 8.8)

AVAILABLE LENGTHS

LYSAGHT® purlins are available custom-cut in any transportable length, however there are some limitations.

For minimum lengths, and lengths over 12000mm, contact your nearest Lysaght office.

For normal deliveries nominal lengths should not exceed 12000mm. Lengths greater than 12000mm require special transportation and on-site handling facilities. Law restricts the hours of transportation and permits may be required in some states. Lengths greater than 19500mm require a special transportation permit.

Length tolerance for all sections is ±5mm.

PACKING

LYSAGHT® Zed and Cee sections are delivered in strapped bundles. The actual quantity in each bundle will vary with section size, order and length. The bundle mass is generally approximately one tonne.

LYSAGHT® accessories are delivered in strapped or wired bundles, bags, or packages as appropriate.

STORAGE ON-SITE

If not required for immediate use, sections should be neatly stacked off the ground and on a slight slope so that water can drain away. Sections and accessories should not be left exposed in the open for extended periods.

ORDERING

To make ordering of the full purlin and girt system easier, every Lysaght Sales Office has order pads available on request.

MATERIAL SPECIFICATIONS

LYSAGHT® Zed and Cee sections are roll-formed from GALVSPAN® steel complying with AS 1397. In the grades shown, the number prefixed with G indicates minimum yield stress in MPa; and the number prefixed with Z indicates minimum coating mass in g/m².

- 1.0 mm BMT: G550, Z350*
- 1.2 mm BMT: G500, Z350*
- 1.5, 1.9, 2.4 and 3.0 mm BMT: G450, Z350*

*All BMTs in Townsville have Z450 coating.

Further information is available from lysaght.com, our Steel Direct Information Service on 1800 641 417 or the local Lysaght Service Centre.

2.2 ZED & CEE SECTIONS - DIMENSIONS AND PROPERTIES

LYSAGHT® ZED SECTIONS

LYSAGHT® Zed sections feature one broad and one narrow flange, sized so that two sections of the same size fit together snugly, making them suitable for lapping.

Continuous lengths of purlin result in better economy, but lapping provides two thicknesses of metal over interior supports. Lapping increases the strength of the sections where bending moments and shear are at a maximum, thus improving the load capacity and rigidity of the system.

LYSAGHT® Zed sections of the same depth and different thicknesses can be lapped in any combination.

LYSAGHT® Zed sections may also be used over simple spans. For shorter spans they may be used continuously over two or more spans without laps – thus producing reduced deflection compared with simple spans – but it does not give the strength of a fully lapped system.

LYSAGHT® Zed sections with one lip turned outward (called downturned lip purlins) may be used in simple or continuous spans with the ends butted.

Typical assemblies are shown later in this manual.

LYSAGHT® CEE SECTIONS

LYSAGHT® Cee sections have equal flanges and are suitable for simply supported spans. For shorter spans they may be used continuously over two or more spans with the ends butted, thus producing reduced deflection compared with simple spans. They cannot be lapped.

Typical assemblies are shown later in this manual.

Zed section

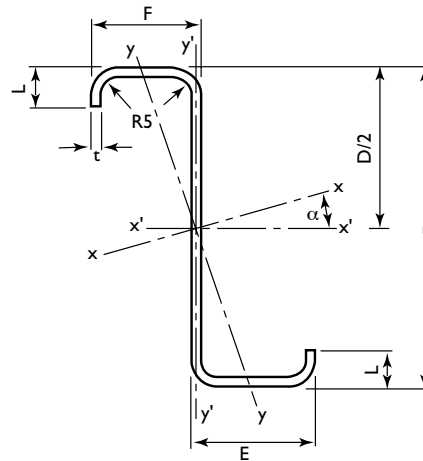

Cee section

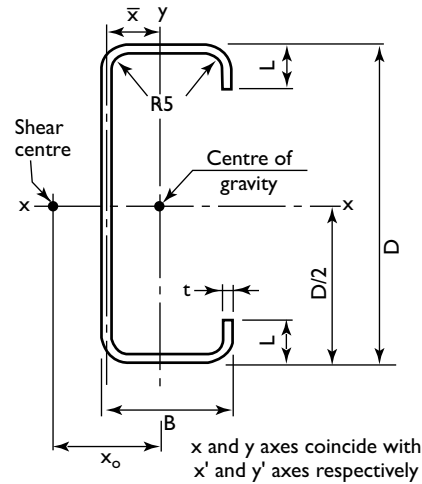

DIMENSIONS OF ZEDS & CEES

Catalogue number	t mm	D mm	Mass per unit length kg/m	Zeds			Cees	
				E mm	F mm	L mm	B mm	L mm
Z/C10010	1.0	102	1.78	53	49	12.5	51	12.5
Z/C10012	1.2	102	2.10	53	49	12.5	51	12.5
Z/C10015	1.5	102	2.62	53	49	13.5	51	13.5
Z/C10019	1.9	102	3.29	53	49	14.5	51	14.5
Z/C15012	1.2	152	2.89	65	61	15.5	64	14.5
Z/C15015	1.5	152	3.59	65	61	16.5	64	15.5
Z/C15019	1.9	152	4.51	65	61	17.5	64	16.5
Z/C15024	2.4	152	5.70	66	60	19.5	64	18.5
Z/C20015	1.5	203	4.49	79	74	15.0	76	15.5
Z/C20019	1.9	203	5.74	79	74	18.5	76	19.0
Z/C20024	2.4	203	7.24	79	73	21.5	76	21.0
Z/C25019	1.9	254	6.50	79	74	18.0	76	18.5
Z/C25024	2.4	254	8.16	79	73	21.0	76	20.5
Z/C30024	2.4	300	10.09	100	93	27.0	96	27.5
Z/C30030	3.0	300	12.76	100	93	31.0	96	31.5
Z/C35030	3.0	350	15.23	129	121	30.0	125	30.0

2.3 SECTION PROPERTIES

LYSAGHT® ZEDS

Product Code	Area	Principal Axes					Axes Perpendicular & Parallel To Web						Column Properties		Effective Section Properties At Yield Stress		
		Second Moment Of Area		Section Modulus	Radius Of Gyration		Second Moment Of Area		Product Moment Of Area	Section Modulus		Radius Of Gyration		Torsion Constant	Warping Constant	Section Modulus In Bending	Area In Compression
		A mm ²	I _x 10 ⁶ mm ⁴	I _y 10 ⁶ mm ⁴	Z _y 10 ³ mm ³	r _y mm	a (°)	I _x ¹ 10 ⁶ mm ⁴	I _y ¹ 10 ⁶ mm ⁴	I _x ¹ ^y 10 ⁶ mm ⁴	Z _x ¹ 10 ³ mm ³	Z _y ¹ 10 ³ mm ³	r _x ¹ mm	r _y ¹ mm	J mm ⁴	I _w 10 ⁶ mm ⁶	Z _x ^e 10 ³ mm ³
Z10010	216	0.451	0.0437	1.55	14.2	27.6	0.364	0.131	0.168	7.00	2.56	41.1	24.7	71.9	215	5.33	113
Z10012	258	0.536	0.0516	1.84	14.2	27.5	0.432	0.155	0.198	8.32	3.02	41.0	24.5	124	253	6.73	153
Z10015	323	0.668	0.0652	2.32	14.2	27.8	0.537	0.197	0.249	10.3	3.84	40.8	24.7	242	321	8.82	217
Z10019	409	0.840	0.0829	2.94	14.2	28.1	0.673	0.250	0.314	13.0	4.92	40.6	24.7	492	409	12.4	329
Z15012	354	1.47	0.115	3.14	18.1	21.8	1.28	0.303	0.469	16.7	4.78	60.3	29.3	170	1160	11.9	169
Z15015	443	1.84	0.145	3.96	18.1	22.0	1.60	0.383	0.588	20.8	6.06	60.1	29.4	332	1460	17.2	248
Z15019	561	2.32	0.184	5.02	18.1	22.1	2.01	0.487	0.744	26.1	7.73	59.9	29.5	675	1860	22.4	347
Z15024	712	2.92	0.238	6.38	18.3	22.5	2.53	0.632	0.950	32.6	10.0	59.6	29.8	1370	2410	31.4	535
Z20015	555	3.89	0.255	5.53	21.4	18.5	3.53	0.621	1.09	34.3	8.05	79.7	33.4	416	4260	23.8	248
Z20019	713	5.02	0.342	7.45	21.9	19.1	4.52	0.843	1.45	43.9	11.0	79.6	34.4	858	5830	36.4	378
Z20024	907	6.36	0.443	9.64	22.1	19.4	5.70	1.10	1.86	55.3	14.4	79.3	34.8	1740	7630	48.4	546
Z25019	808	8.08	0.381	7.82	21.7	14.0	7.62	0.833	1.81	59.3	10.8	97.1	32.1	972	9480	45.7	379
Z25024	1030	10.2	0.493	10.2	21.9	14.3	9.64	1.08	2.33	74.9	14.2	96.9	32.5	1970	12400	66.0	547
Z30024	1260	18.3	1.01	16.8	28.3	16.0	17.0	2.32	4.57	112	23.8	116	42.8	2430	36600	89.9	628
Z30030	1600	23.1	1.32	21.9	28.7	16.3	21.3	3.04	5.88	140	31.4	116	43.6	4790	48200	125	908
Z35030	1910	39.2	2.49	32.8	36.1	17.8	35.8	5.93	10.7	202	47.2	137	55.7	5730	124000	159	940

Properties have been computed on the basis of mean flange width. The introduced error is negligible. The shear centre and monosymmetry constant deviations can be disregarded, that is, taken as zero.

LYSAGHT® CEES

Product Code	Area	Full Section Properties						Column Properties					Effective Section Properties At Yield Stress	
		Second Moment Of Area		Section Modulus		Radius Of Gyration		Centroid	Shear Centre	Torsion Constant	Warping Constant	Monosymmetry Section Constant	Section Modulus In Bending	Area In Compression
		A mm ²	I _x 10 ⁶ mm ⁴	I _y 10 ⁶ mm ⁴	Z _x 10 ³ mm ³	Z _y 10 ³ mm ³	r _x mm	r _y mm	\bar{x} mm	x ₀ mm	J mm ⁴	I _w 10 ⁶ mm ⁶	b _y mm	Z _x ^e 10 ³ mm ³
C10010	216	0.364	0.0755	713	2.19	41.1	18.7	16.1	39.9	71.9	160	123	5.37	113
C10012	258	0.432	0.0892	8.48	2.59	41.0	18.6	16.0	39.7	124	188	123	6.74	153
C10015	323	0.537	0.112	10.5	3.29	40.8	18.7	16.1	40.1	242	241	122	8.73	217
C10019	409	0.673	0.142	13.2	4.21	40.6	18.7	16.2	40.4	492	311	122	12.3	329
C15012	354	1.29	0.188	17.0	4.17	60.4	23.1	18.3	46.5	170	842	171	11.8	165
C15015	443	1.61	0.237	21.1	5.29	60.2	23.1	18.4	46.9	332	1070	171	17.1	244
C15019	561	2.02	0.300	26.6	6.74	60.0	23.1	18.5	47.1	675	1370	170	21.8	340
C15024	712	2.54	0.386	33.5	8.79	59.8	23.3	18.9	48.0	1370	1810	169	30.9	527
C20015	555	3.53	0.396	34.7	7.7	79.7	26.7	19.9	51.6	416	3060	223	24.1	251
C20019	713	4.51	0.531	44.4	9.77	79.6	27.3	20.8	53.6	858	4240	221	36.6	381
C20024	904	5.69	0.681	56.0	12.7	79.3	27.4	21.1	54.4	1740	5540	219	47.5	541
C25019	808	7.62	0.561	60.0	9.86	97.1	26.4	18.1	48.5	972	6860	276	46.2	381
C25024	1020	9.62	0.721	75.7	12.8	96.9	26.5	18.4	49.3	1970	8920	274	64.9	543
C30024	1260	17.0	1.51	113	21.7	116	34.6	25.0	66.0	2430	26800	320	91.1	632
C30030	1600	21.3	1.96	142	28.5	116	35.0	25.8	67.9	4790	35700	316	124	897
C35030	1910	35.8	3.82	205	42.3	137	44.7	33.2	86.3	5730	90000	378	159	940

3.0 HOOK-LOK® II Bridging System

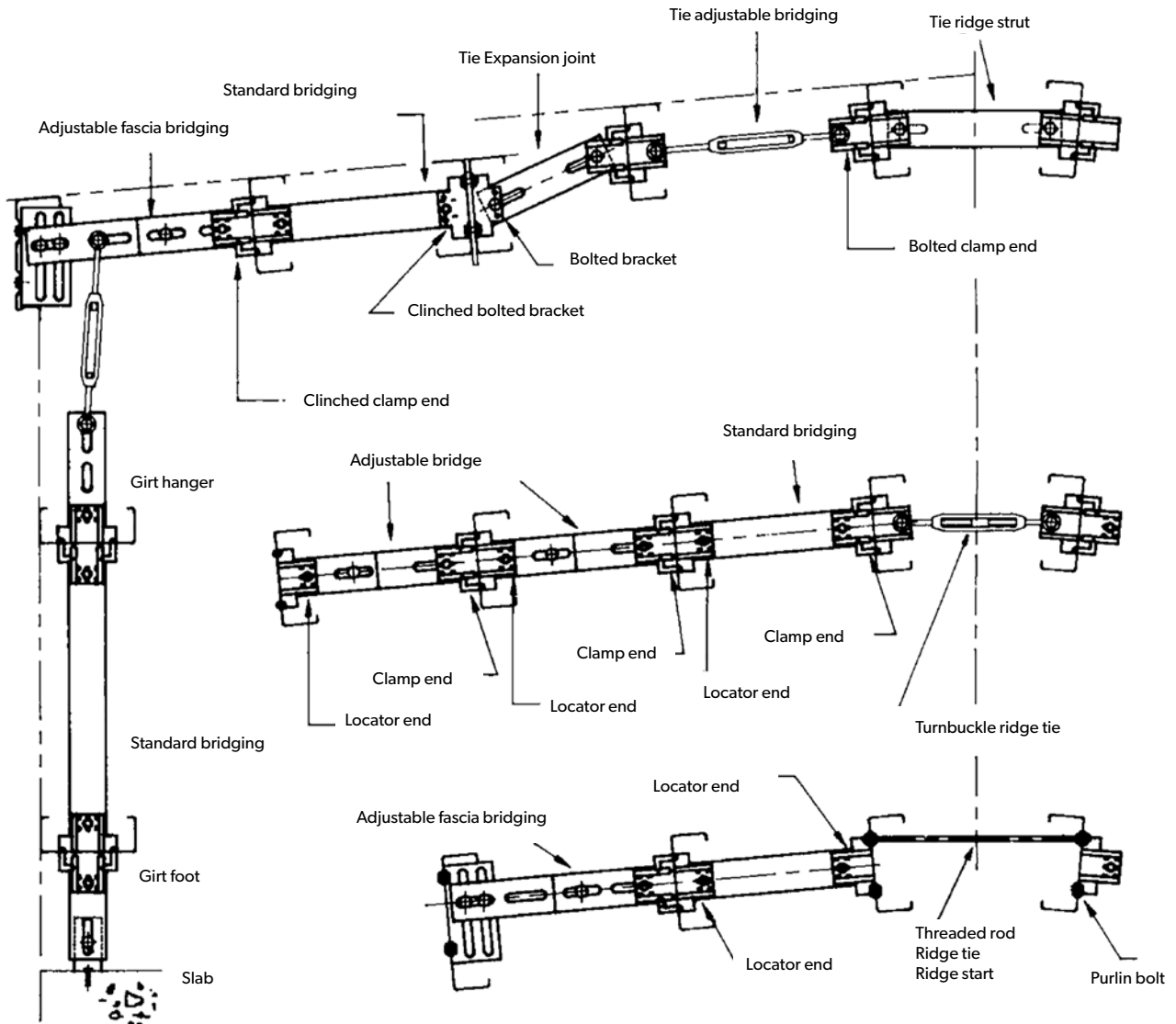

The LYSAGHT HOOK-LOK® II bridging system is the most adaptable and flexible bridging system available, to securely brace both Zed and Cee purlins and girts of depths 100, 150, 200 and 250mm. It is also fast and easy to install and can accommodate most construction configurations.

The system consists of solid bridging assemblies between purlins and girts, and adjustable bridging assemblies at locations such as eaves, ridge and girt foot.

Purlins and girts display two types of lateral instability: lateral deflection and twist (rotation or roll). It is necessary to control these instabilities by providing suitable bracing as close as possible to the flanges of the section.

Bracing can be continuous (such as rigid cladding suitably fastened to the flange), or point bracing at the midspan region (or at a point of maximum bending), or several points at the midspan region.

In practice, LYSAGHT® claddings with screw fasteners are a suitable lateral bracing when attached to the flange. However, as with all thin-walled claddings, the twisting resistance is difficult to quantify. Consequently, point bracing is still required to resist twist of the section and lateral deflection of the free flange. Point bracing is also required to stabilise and straighten the purlins and girts prior to fixing of the cladding in order to facilitate the fixing operations.

Point bracing types are 'ties' and 'bridging'. Ties can be loaded in tension only. Bridgings are solid members secured to the webs of the purlins and girts. They can be loaded in tension, compression and bending.

For this reason, a continuous run of bridging is the most effective stabiliser for both wall and roof, and is the most widely accepted.

FASCIA BRIDGING SYSTEM

In certain configurations of wall design, the loads imposed on the fascia system by the girt hanger may be large. This demands an increase in the fascia system capacity to prevent excessive twisting.

COMPONENTS

The basic parts of each HOOK-LOK® II bridging assembly are the locators and clamps. They firmly lock each purlin or girt in position when simply located and hooked into the bridging holes from opposite sides of the web.

Locators and clamps have hook centres to match the holes punched in the webs of LYSAGHT® purlins and girts. The hole punching in the purlins and girts match the holes for cleat supports of the purlin and girts.

HOOK-LOK® II components are not sold individually, only as part of a bridging assembly.

The examples show assemblies with the ends of equal size, however the system works well for assemblies with unequal ends.

BRIDGING ASSEMBLY





Bridging assemblies are supplied in lengths to suit the nominated purlin or girt spacing. There are some limitations on minimum lengths.

With the flexibility of component combinations it is possible to make many bridging assemblies. The HOOK-LOK® overview shows bridging configurations.

Typical bridging assemblies include:

- Standard bridging assembly
- Ridge bridging assembly
- Girt foot/hanger bridging assembly
- Fascia bridging assembly
- Adjustable bridging assembly
- Expansion joint

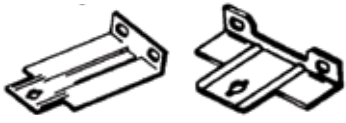
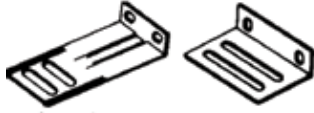
PRODUCT CODES FOR HOOK-LOK® II PARTS

Ends	Mark No.	
Clamp end CODE C	C10 C15 C1V* C20 C25	
Locator End CODE L	L10 L15 L1V* L20 L25	
Bolted bracket ends CODE B	B10 B15 B20 B25	
Fascia brackets CODE F	F20 F25	
Girt bracket end CODE G	G	

PRODUCT CODES

HOOK-LOK® II bridging assembly catalogue numbers indicate purlin size (nominal depth). Locators, clamps and other accessories are matched to the purlin size.

HOW TO SPECIFY

When specifying HOOK-LOK® II bridging assemblies:

1. Specify the HOOK-LOK® II prefix H2.
2. Specify left hand end component – always three characters (e.g. C20)
3. Specify the type of bridging channel – always one character (e.g. P)
4. Specify right hand end component – three characters (e.g. L20)

Putting these together, you would get: H2 C20 P L20.



EXAMPLE 1

An adjustable bridging, with clamp to suit a C15015 purlin at one end and a bolted bracket to suit a C20024 purlin at the other end would be: H2 C15 T B20.

(This assumes that the order was not for use in Victoria where the product code would be H2 C1V T B20 – see note to product codes table.)

EXAMPLE 2

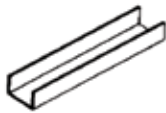
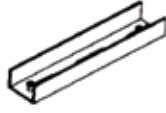
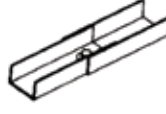
Fascia bridging, to span between a C20024 used as a fascia purlin and C20015 purlin, would be: H2 F20 D L20.

Channels & Turnbuckles	Mark No.	
Bridging channel: plain CODE P	P	
Bridging channel: socketed CODE S	S	
Bridging channel: double CODE D	D	
Turnbuckle CODE T	T10† T12†	
Tie Rods	Mark No.	
Tie rod CODE R	R12† R16†	

* For Victoria, 150 size bridging is specified using a 'V' instead of the '5'
† 10, 12 or 16 refer to rod diameter in mm

3.1 HOOK-LOK® II BRIDGING INSTALLATION

PURLIN BRIDGING

HOOK-LOK® II bridging into Zed or Cee purlins may be installed in numerous ways. The normal procedure is to commence from the eave or ridge.

A typical installation procedure is:

Step 1: Install the fascia bridging assembly by inserting the locator end into the holes of the first purlin, and bolting the fascia bracket to the fascia purlin.

Step 2: Install the standard bridging assemblies working towards, and finishing at, the ridge purlin. Standard assemblies are installed by fitting the clamp end over the previously-installed locator end and swinging the bridging around until the locator end engages in the holes of the next purlin.

Step 3: Where applicable, repeat Steps 1 and 2 for the opposite side of the roof. If appearance is a consideration, the bridging runs on both sides of the roof should be swung into position from the same end of the roof.

Step 4: Install the ridge bridging assembly by fitting the clamp ends over the previously installed locator ends and then tightening the bolts of the ridge assembly.

When a ridge bridging assembly is not used, the locator(s) of the standard bridging is secured into position with two bolts.

Step 5: Where turnbuckles are used in a bridging assembly, first align the purlins. Align the fascia purlin using the, adjustment bolts of the fascia bridging assembly.

GIRT BRIDGING

The recommended procedure is to commence at floor level and work towards the eaves. A typical installation procedure is:

Step 1: Install the girt foot assembly by engaging the locator into the holes of the bottom girt. Due to the loads transferred to the bridging from the girts, the girt foot assembly must be anchored to the slab.

Step 2: Adjust the girt foot assembly to level off the bottom girt. Where the slab is not yet poured, a temporary support is required to keep the bottom girt level.

Step 3: Install standard bridging assemblies as described in Step 2 for purlin bridging, working towards the eaves.

Step 4: At the top girt, the locator is secured into position with two bolts. If appearance is a consideration ensure the girt and purlin bridging are installed facing the same direction. Where a girt hanger is used it is installed by fitting the clamp end over the last installed locator end and swinging the bridging around, then bolting the turnbuckle to the fascia bridging.

In projects where no girt foot assembly is used, particular care in design and construction is required.

We recommended the following precautions during construction:

1. The roof sheeting should be installed before the turnbuckle of the girt hanger is used to level the girts, which would impose loads on the fascia system; and
2. Provide a temporary girt support under the bottom girt until the installation of the wall cladding is complete for that section.

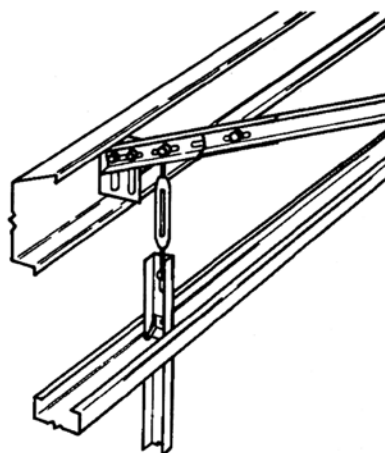
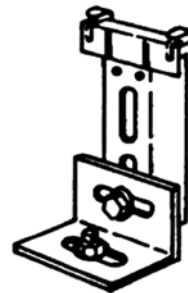
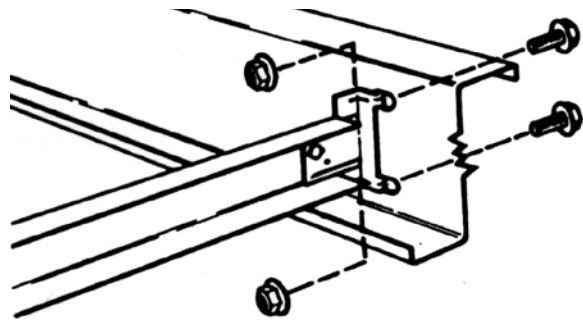
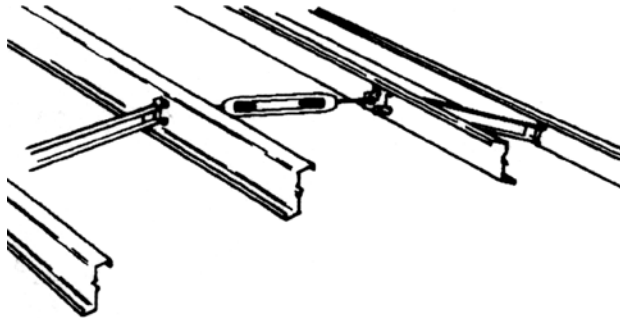
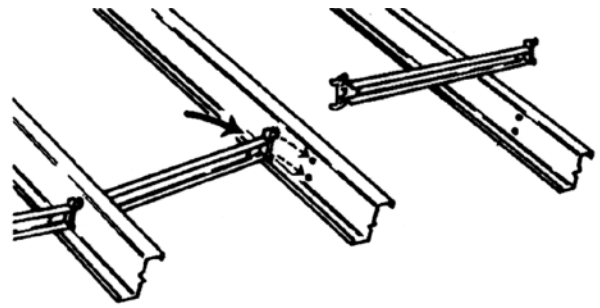

4.0 LYSAGHT® Series 300 & 350 Bridging System

For the larger sections, 300 and 350 series (LYSAGHT® Big Zeds and Big Cees), a more substantial bridging system is required, due to larger spans and greater loads.

The bridging components are bigger and have additional lip stiffening.

The components consist of a C15015 channel and bridging ends assembled with LYSAGHT® high-strength M12 x 30mm purlin bolts.

All components are galvanised for long life and can be assembled using the recommended bolts or by welding.

When ordering, the overall bridging length should be specified, i.e. purlin or girt spacing, less 3mm. Catalogue numbers for the bridging are:

- BZ300 or BZ350.

With regard to wall heights and girt spans, please contact Lysaght Steel Direct for guidance.

Typical Series 300/350 bridging

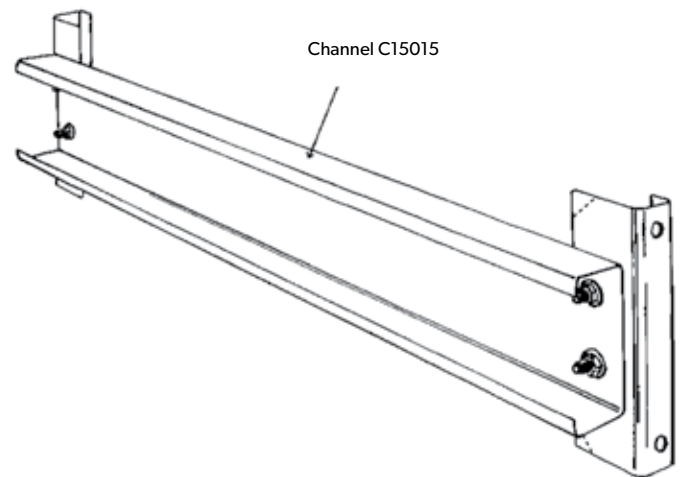

BRIDGING END DIMENSIONS

Depth of Purlin (mm)	Catalogue No.	Dimensions		
		A	B	E
300	300 EB	260	60	210
350	350 EB	310	60	260
300 (VIC Only)	300 EBV	260	70	210
350 (VIC Only)	350 EBV	310	70	260

Bridging end

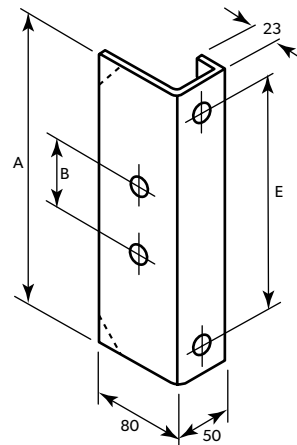

5.0 Purlin & Girt Accessories

Manufactured from zinc-coated steel, accessories are an integral part of LYSAGHT® purlin and girt systems.

PURLIN BOLTS

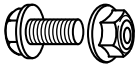

M12 SIZE

PB1230 LYSAGHT® standard purlin bolt (grade 4.6):
M12 x 30mm with nut.

PB1230HS LYSAGHT® high-strength purlin bolt (grade 8.8):
M12 x 30mm with nut.

PBS1230 LYSAGHT® shouldered purlin bolt (grade 4.6)
with 16mm shoulder: M12 x 30mm with nut.

M16 SIZE

PB1645 LYSAGHT® standard purlin bolt (grade 4.6):
M16 x 45mm with nut.

PB1645HS LYSAGHT® high-strength purlin bolt (grade 8.8):
M16 x 45mm with nut.

ANGLE CONNECTORS

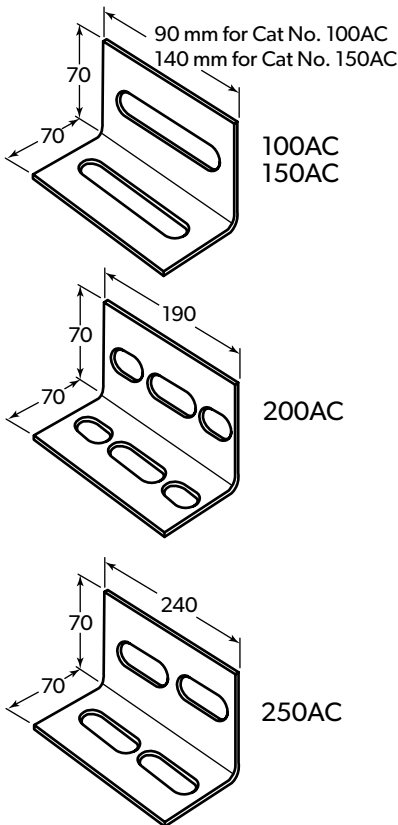

RAKING GIRT

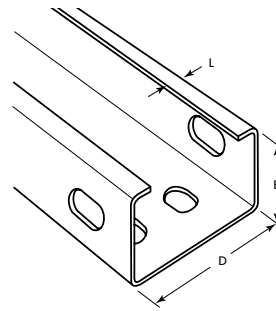

Cat. No	D (mm)	B (mm)	L (mm)
C10015	102	51	13.5
C15015	152	64	15.5

RAKING GIRT BRACKET

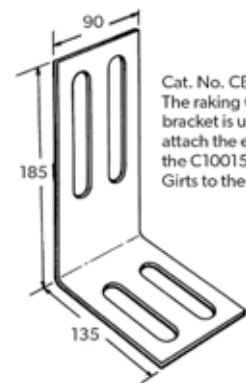

Cat. No. CB100RB
The raking Girt bracket is used to attach the ends of the C10015 Raking Girts to the fascia.

CLEATS

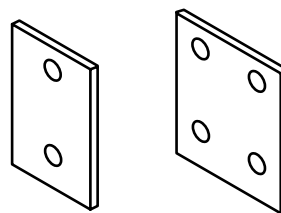

CLAMP PLATES

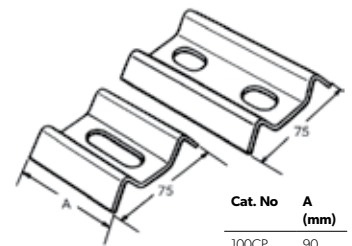

Cat. No	A (mm)
100CP	90
150CP	140
200CP	190
250CP	240

GENERAL PURPOSE BRACKETS

BRACKET DIMENSIONS

Bracket Product Code	G (mm)	H (mm)	I (mm)	J (mm)	K (mm)	L (mm)
100GPB	13	40	13	30	54	31
150GPB	22.5	60	22.5	30	67	28
200GPB	22	110	22	36	73	27
250GPB	20	160	20	36	73	27

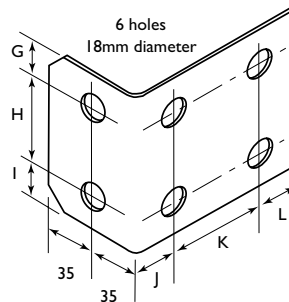

GPB100

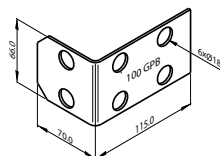

GPB150

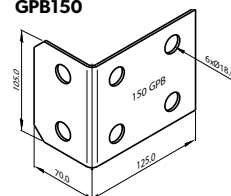

GPB200

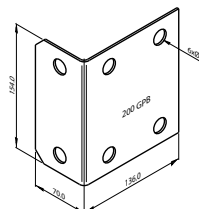

GPB250

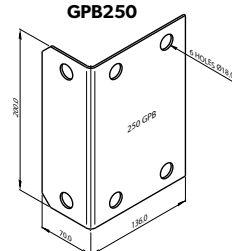

6.0 Typical Assemblies

6.1 USING PURLIN & GIRT ACCESSORIES

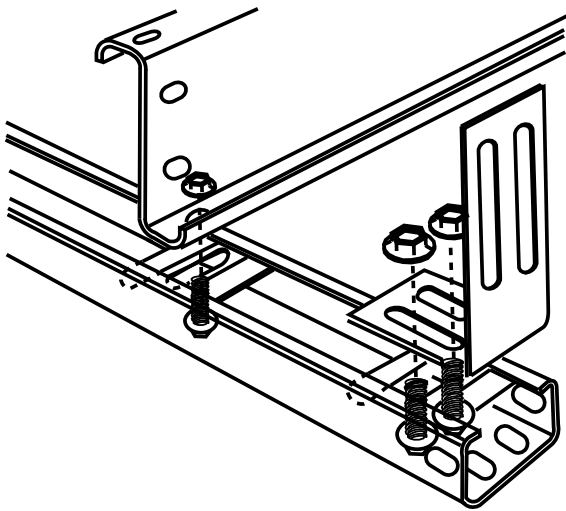

ANGLE CONNECTOR

The Angle Connector can be used in a variety of different ways. The holes allow connection between sections of the same size or one size smaller. Figure (a) shows the angle connector and clamp plate as a foot mounting for lightly loaded vertical members such as jambs for personnel access doors or windows. It can also be used as a column base in lightly loaded or internal applications. Figure (b) shows a closed end on a girt. This obviates the need for mitred girts at corners while still providing a satisfactory attachment point for the cladding and corner treatment. Figure (c) shows a simple mitred 90° joint. Figure (d) shows the angle connector and clamp plate used as an attachment for trimmers or non-load-bearing heads to openings.

RAKING GIRT ASSEMBLY

Shown is one method of fitting raking girts using bolts and clamp plates. The raking girt bracket is used to attach the end of a C10015 raking girt to the fascia purlin.

Alternatively the raking girt can be installed open face down. The clamp plates are deleted and the girt attached with bolts fitted through holes pre-punched in the web of the purlin.

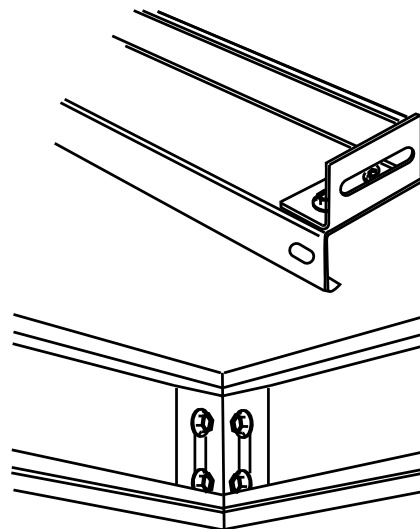
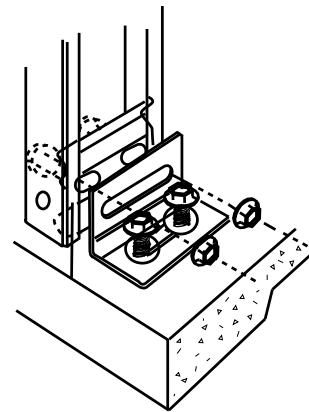
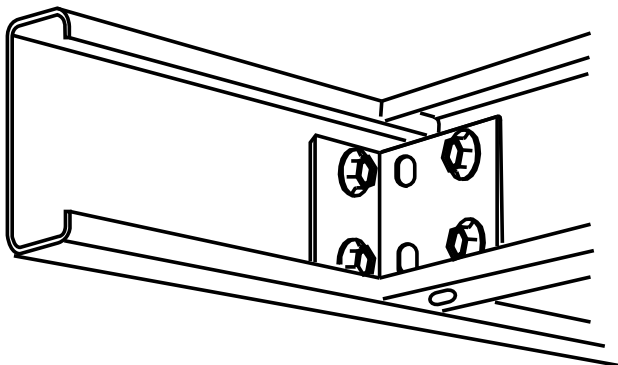

GENERAL PURPOSE BRACKET

The general purpose bracket is ideal for making joints of approximately 90° and is usually used for joining sections of the same web depth. Typical applications include lightly loaded heads to openings, trimmers and fascias at gable ends.

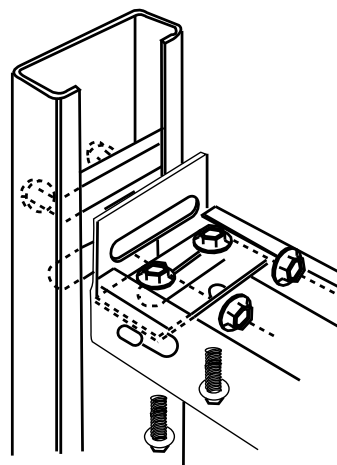

6.2 TYPICAL ASSEMBLIES - ZEDS

Typical assembly using LYSAGHT® Zed sections and HOOK-LOK® II bridging.

Where fly bracing is used in conjunction with lapped Zed sections it is important that the bolt requirements for lapping are not compromised.

Zed purlins

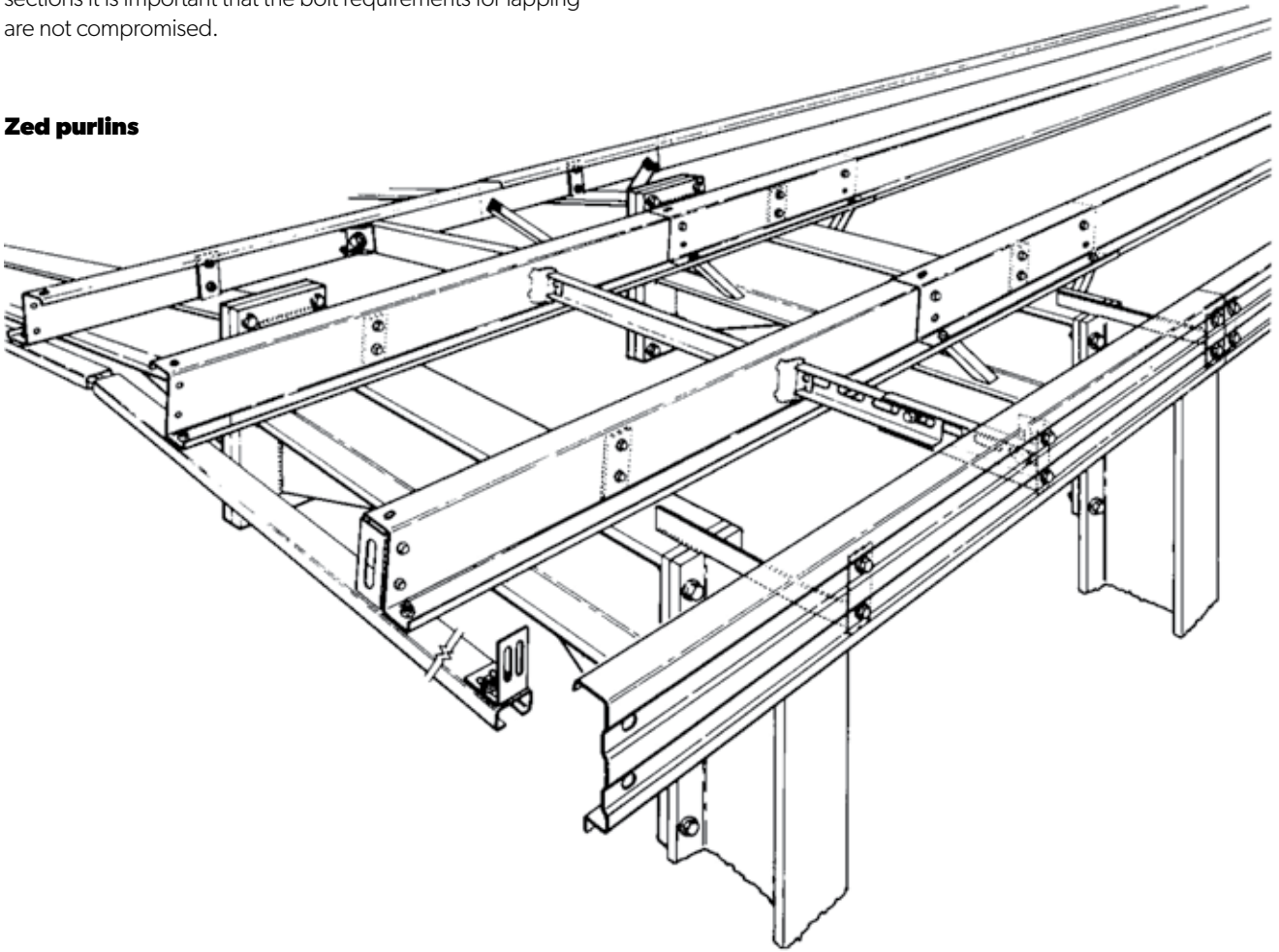

Zed girts

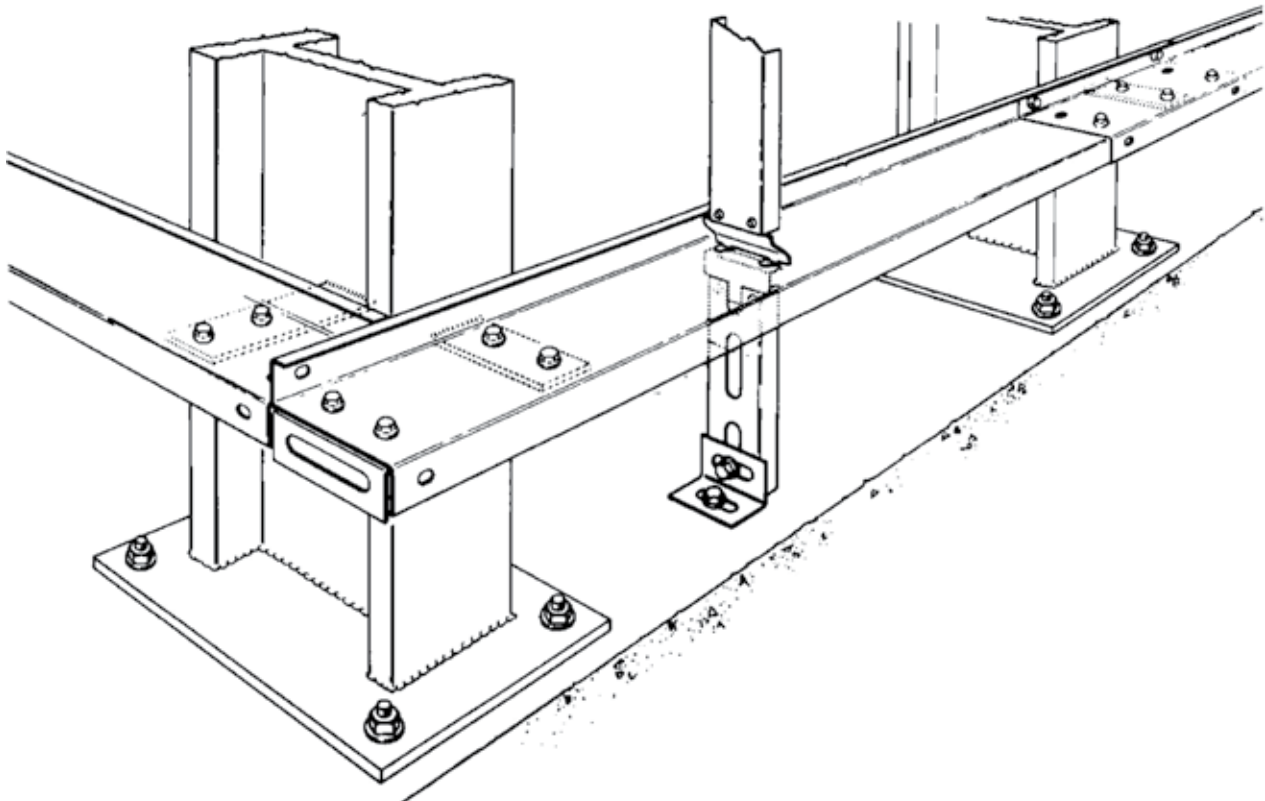

6.3 TYPICAL ASSEMBLIES - CEES

Typical assembly using LYSAGHT® Cee sections and HOOK-LOK® II bridging.

Cee purlins

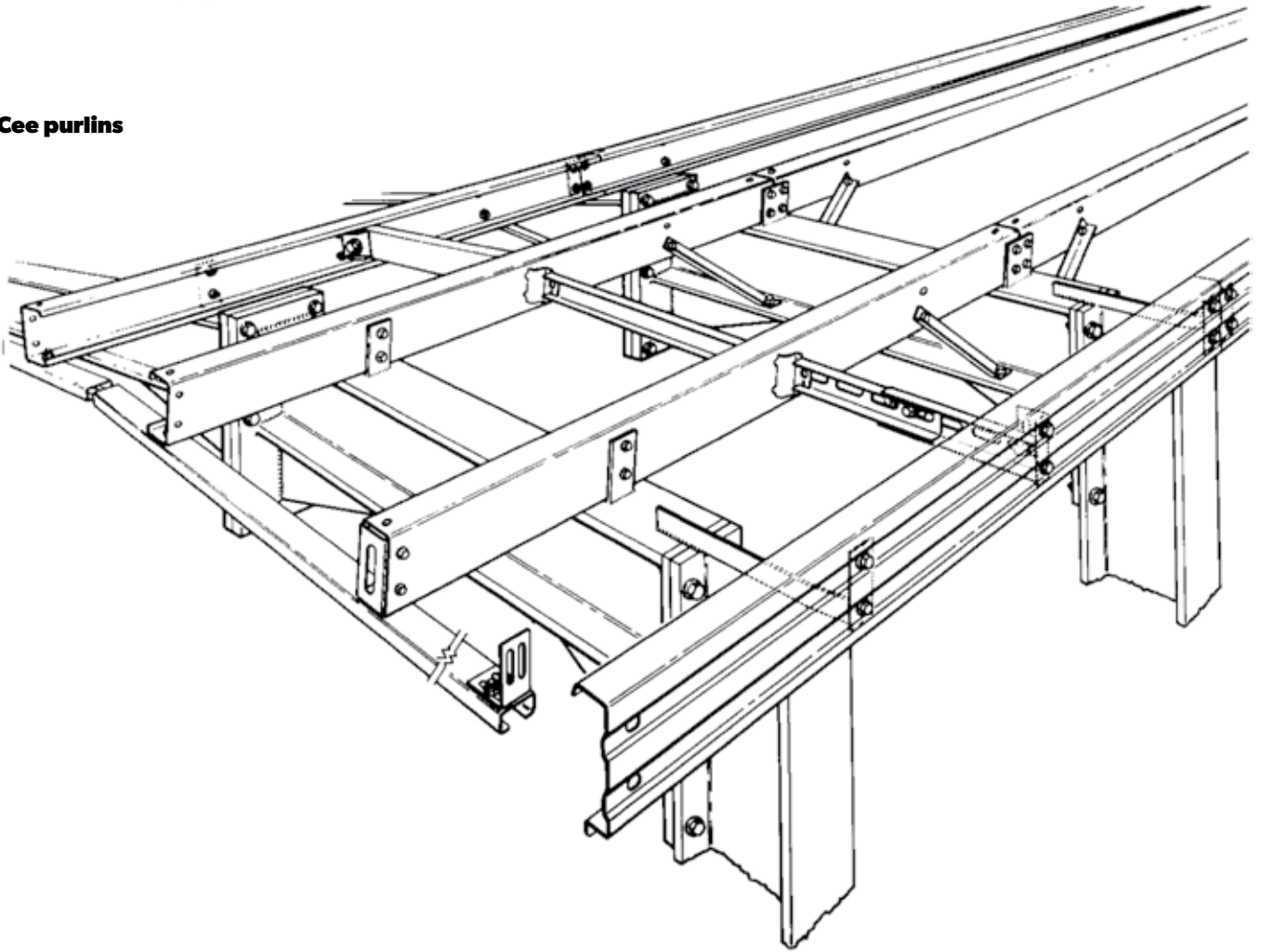

Cee girts

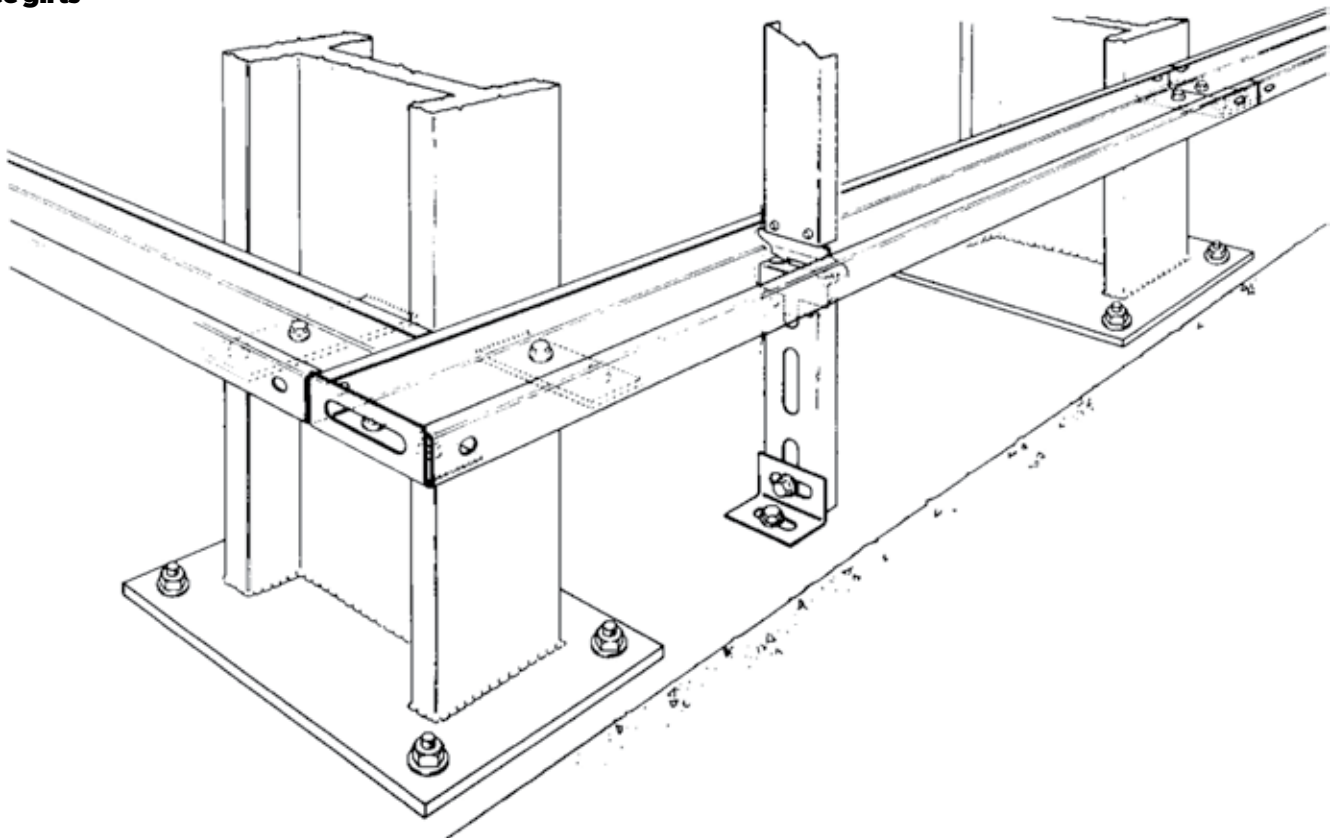

7.0 Holes & Cleats

LYSAGHT® Zed and Cee sections are normally supplied with holes punched to the Australian Institute of Steel Construction (AISC) gauge lines, except, in Victoria where the 150 series sections are punched to the Structural Steel Fabricators Association, Victoria, recommended gauge lines.

HOLE DETAILS AND GAUGE LINES FOR LYSAGHT® ZED & CEE SECTIONS

Dimensions in mm

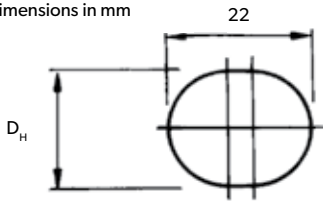

BlueScope Lysaght standard elongated punched hole. Holes equally spaced above and below centre line.

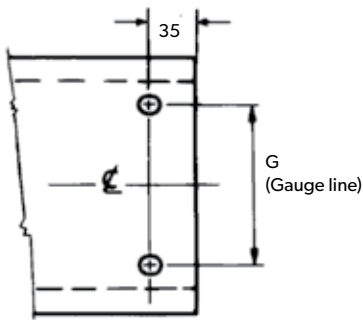

CENTRELINE HOLES FOR 300 AND 350 SECTIONS ONLY

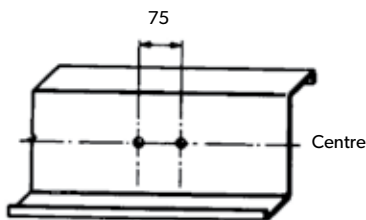

Nominal Section Size (mm)	G (mm)	D _H
100	40	18
150 (VIC only)	70	18
150 (Other States)	60	18
200	110	18
250	160	18
300	210	22
350	260	22

The holes are required at cleat supports at ends of laps and at bridging points.

For the webs of 300 and 350 sections (Big Zeds and Big Cees), centreline holes are also available on request, and may be combined with cleat holes to provide 3-bolt fastening to the cleats.

For the 100, 150, 200 and 250 deep sections the holes are elongated with dimensions of 18mm x 22mm suitable for M12 bolts. For the 300 and 350 deep sections the holes are 22mm diameter suitable for M16 bolts. Sections are also available unpunched if required.

For special projects the size of the hole, the number of holes, and the gauge lines may be modified by negotiation. These projects will be subject to minimum order quantities and extended lead times.

With regard to wall heights and girt spans, please contact Lysaght Steel Direct for guidance.

STANDARD HOLES FOR CEE SECTIONS

Simple Connection

Edge distance 35mm

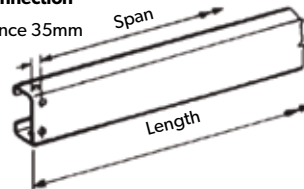

End Bay

Overhang varies

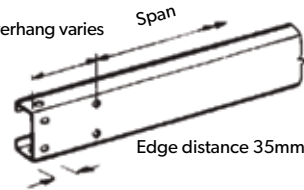

STANDARD HOLES FOR ZED SECTIONS

Lapped connection

Edge distance 35mm

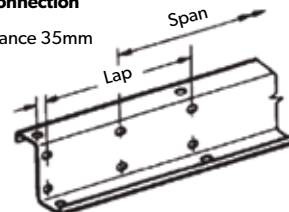

End Bay

Overhang varies

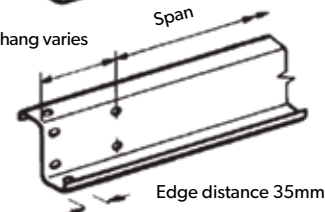

Simple connection

Edge distance 35mm

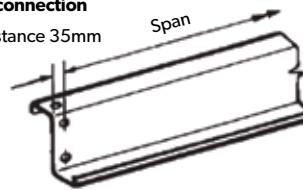

BRIDGING HOLES AND CLEAT HOLES

Gauge lines

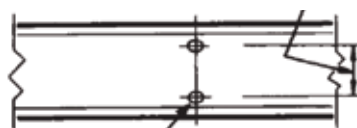

Holes for bridging and cleats

HOLE DETAILS OF CLEATS

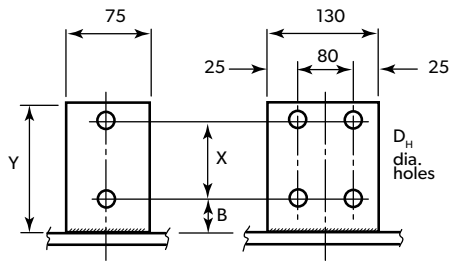

CLEAT NOMINAL DIMENSIONS (MM)

Nominal Section Size (mm)	X	B	Y	t (thickness)	Gap	D_H
100	40	40	105	8	10	18
150 (VIC only)	70	50	145	8	10	18
150 (Other States)	60	55	145	8	10	18
200	110	55	195	8	10	18
250	160	55	245	8	10	18
300	210	65	305	12	20	22
350	260	65	355	12	20	22

When using Zed sections with downturned lips, longer cleats are required to give clearance from the main supports.

FASTENING TO CLEATS

Zed purlins lapped

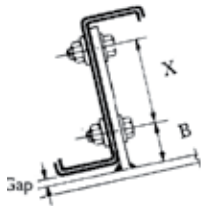

Zed girts standard mode

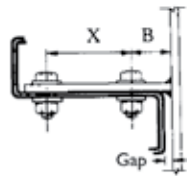

Zed girts optional mode

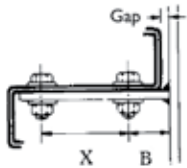

Cee purlins

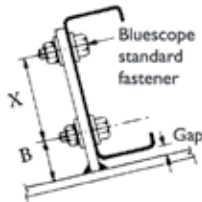

Cee girts standard mode

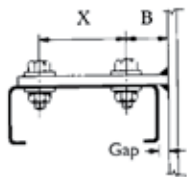

Cee girts optional mode

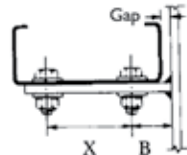

NOTE: To minimise the tendency of Zeds and Cees to rotate when used as purlins, it is necessary to have the top flange pointing up the slope. Purlin orientation may be a consideration in certain projects.

LOCATION OF BRIDGING HOLES

SINGLE SPANS

Simple spans

One row of bridging

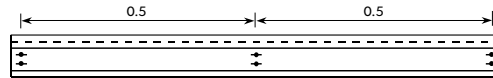

Two rows of bridging

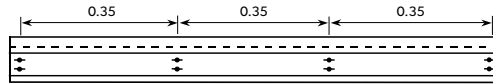

Three rows of bridging

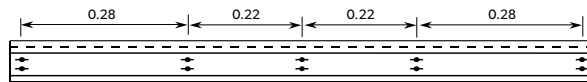

End spans (continuous)

One row of bridging

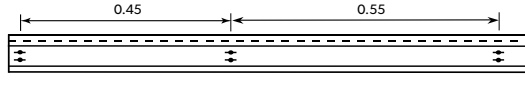

Two rows of bridging

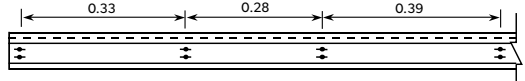

Three rows of bridging

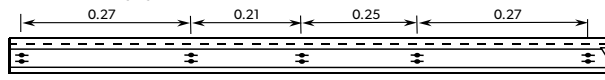

End spans (lapped)

One row of bridging

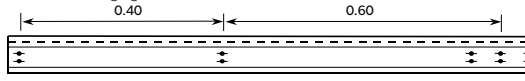

Two rows of bridging

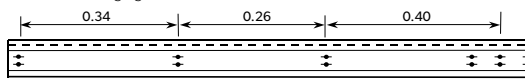

Three rows of bridging

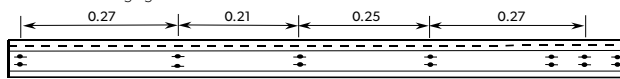

INTERIOR SPANS (LAPPED AND UNLAPPED)

One row of bridging

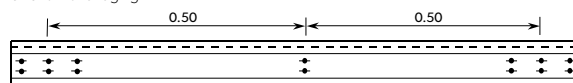

Two rows of bridging

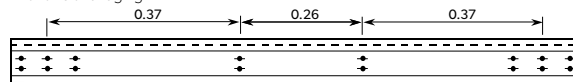

Three rows of bridging

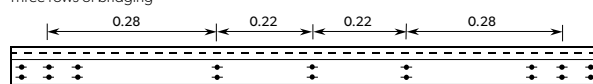

8.0 Design Notes for Capacity Tables

When determining a design, consideration should be given to load combinations for both strength and for serviceability.

DESIGN PHILOSOPHY

The limit state capacity tables have been compiled using a finite element flexural torsional buckling analysis for modelling the whole purlin system. The model considers both in-plane distribution of axial force, shear force and bending moments, as well as out of plane buckling modes.

The finite element flexural torsional buckling analysis assumes that:

- all purlins bend about the axis which is perpendicular to the web;
- there is continuity at the laps;
- there is minor axis translation and twisting restraint at the bridging points;
- there is lateral stability in the plane of the roof at internal supports and the ends of cantilevers; and
- both screw-fastened and concealed-fixed claddings provide restraint.

All design calculations for both strength and serviceability are in accordance with AS/NZS 4600.

DEFLECTION

There are no specific rules governing acceptable deflections, though structural codes give guidance. You need to consider the specific requirements of any structure. It may be necessary to design for deflection under more than one load combination. See also Assumptions used in tables.

AXIAL LOADS

Where a section is not loaded to its full capacity in bending, it has a reserve of strength to carry some axial load. This reserve in purlins and girts can be used to transmit forces due to wind loading on end walls, or to resist forces due to bracing of wall and roof structures.

Where required, the combined bending and axial load capacity should be calculated using AS/NZS 4600.

POINT LOADS

The values in this publication assume uniformly distributed loading. However, in many applications (like the mounting of services and maintenance equipment) the loads applied to a structure are point loads. Thus, to use these tables for point loadings, the loads must be converted to equivalent distributed loads.

The table on the following page gives conversion formulae for loads on simple spans and lapped spans. They have been derived from commonly published moment and shear data, and give conservative conversions.

For simple spans the formulae are straight forward. For non-continuous lapped spans the formulae depend on the number of spans, the position of the span and the lapping ratio; thus the worst-case configuration has been used, and the values may be safely used for end spans, interior spans and any lapping ratio greater than 10%.

Formulae for loads on continuous unlapped configurations, and for deflections in all configurations, are not given but may be derived similarly.

Symbols used in table for conversion of point loads

P = single point load (kN)

L = span (m)

a = larger distance from support (m)

b = smaller distance from support (m)

w = equivalent uniform load (kN/m)

N = number of point loads over one span (for 6 or more loads)

DESIGN OPTIMISATION

The capacity tables provide economical design solutions for most projects. Designs can be optimised by varying:

- Material specifications
- Bolt specifications and number
- Non-standard purlin profile
- Reduced or enlarged end spans
- Span range
- Cantilevers at one or both ends
- Lap length
- Bridging quantity
- Load distribution

BRIDGING

The capacity tables give solutions for an equal number of rows of bridging in each span. Provision is made for 0, 1, 2 or 3 rows of bridging.

With regard to wall heights and girt spans, please contact Lysaght Steel Direct for guidance.

In practice it may be necessary to use at least one row of bridging in each span. We suggest that unbridged lengths be limited to 20 times the section depth.

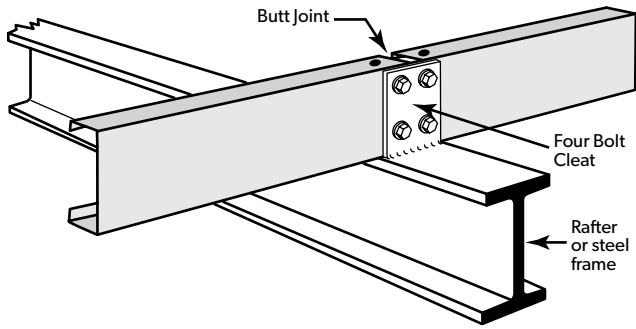

CLEAT CONNECTIONS

The capacity tables are based on the sections being fastened using two bolts through the web to cleats (cleat connection) so that the load path is via the web of the sections.

The connections may be single section thickness such as in end connections, or the internal support connection of continuous configurations. Connections with double section thickness occur at the internal support of lapped configurations.

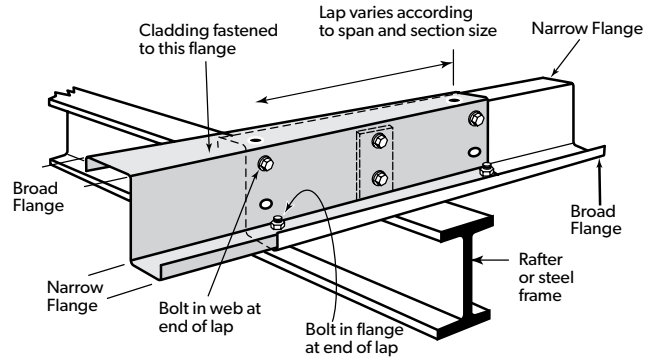

CLEATLESS CONNECTIONS

Fixing of purlins through the bottom flange of the purlin (cleatless connection) is used in some forms of construction. The purlin capacity tables should not be used for these types of connections. For these types of connections there are other design issues (both strength and serviceability) and construction issues that need to be considered.

CONVERSION OF POINT LOADS INTO EQUIVALENT UNIFORM LOADS

Symmetrical equidistant point loads

Loading condition			Conversion formula
SINGLE LOAD	Simple		$w = 2P/L$
	Lapped		$w = 2.22P/L$
2 LOADS	Simple		$w = 2.67P/L$
	Lapped		$w = 3.16P/L$
3 LOADS	Simple		$w = 4P/L$
	Lapped		$w = 3.78P/L$
4 LOADS	Simple		$w = 4.80P/L$
	Lapped		$w = 5.12P/L$
5 LOADS	Simple		$w = 6P/L$
	Lapped		$w = 6.65P/L$
6 OR MORE LOADS	Simple		$w = 1.14NP/L$
	Lapped		$w = 1.22NP/L$

Single eccentric and two symmetrical point loads

Loading condition			Conversion formula
SINGLE ECCENTRIC POINT LOAD	Simple		$w = 8abP/L^3$
	Lapped		$w = 17.76ab^2P/L^4$
2 SYMMETRICAL POINT LOADS	Simple		$w = 8bP/L^2$
	Lapped		$w = 9.45b(2L-3b)P/L^3$

LAPPING

The structural lap at the interior supports of lapped configurations must be detailed to provide adequate structural continuity.

Each end of the lap must have one bolt through the flange furthest from the cladding, and one bolt through the webs near the flanges connected to the cladding.

The nominal lap length is the distance between the bolt centres at the end of the laps. Laps vary in length with both section size and span as shown in the table below. In no situation must the lap be less than 10% of the span.

LAP LENGTHS

Nominal section size (mm)	Span (mm)	Lap length (mm)
100	≤ 6000	600
	> 6000	900
150,200,250	≤ 9000	900
	> 9000 ≤ 12000	1200
	> 12000*	1800
300,350	≤ 9000	900
	> 9000 ≤ 12000	1200
	> 12000 ≤ 18000	800
	> 18000*	2400

* Load capacities for these spans are beyond the scope of this publication.

INTERMEDIATE VALUES

Within a given bridging configuration, capacities for intermediate spans may be interpolated linearly.

NOTES TO CAPACITY TABLES

1. Loads are assumed to be uniformly distributed (see also Point Loads).
2. The capacities assume the use of approved Lysaght’s sections, bridging system and bolts.
3. The column, Load for deflection span/150, is the load that will produce this deflection. It is not a design capacity.
4. All connections use LYSAGHT® purlin bolts grade 4.6, except for boldened capacities which require grade 8.8.
5. Forces acting to hold cladding against a structure are defined as inward. Forces acting to remove cladding from a structure are defined as outward.

Loading condition

Outward Load

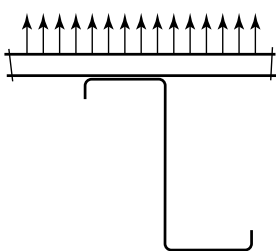

Inward Load

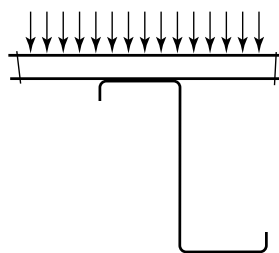

9.0 Limit State Capacity Tables

SINGLE SPANS

Span mm	Z/C 10010 (kN/m)						Z/C 10012 (kN/m)							
	INWARD		OUTWARD				L/150	INWARD		OUTWARD				L/150
	0, 1, 2, 3	0	1	2	3	0, 1, 2, 3		0	1	2	3			
2100	3.97	3.39	3.97	3.97	3.97	3.56	4.84	4.11	4.84	4.84	4.84	4.34		
2400	3.04	2.18	3.04	3.04	3.04	2.42	3.70	2.58	3.70	3.70	3.70	2.96		
2700	2.40	1.47	2.40	2.40	2.40	1.72	2.93	1.79	2.93	2.93	2.93	2.12		
3000	1.95	1.01	1.95	1.95	1.95	1.27	2.37	1.29	2.37	2.37	2.37	1.57		
3300	1.61	0.75	1.59	1.61	1.61	0.97	1.96	0.94	1.88	1.96	1.96	1.20		
3600	1.35	0.57	1.21	1.35	1.35	0.76	1.65	0.70	1.47	1.65	1.65	0.93		
3900	1.15	0.43	0.93	1.15	1.15	0.60	1.40	0.53	1.13	1.40	1.40	0.73		
4200	0.99		0.72	0.99	0.99	0.49	1.21		0.86	1.21	1.21	0.59		
4500	0.87		0.57	0.87	0.87	0.40	1.05		0.69	1.05	1.05	0.48		
4800	0.76		0.46	0.76	0.76	0.33	0.93		0.56	0.90	0.93	0.40		
5100	0.67			0.63	0.67	0.28	0.82		0.46	0.76	0.82	0.33		
5400	0.60			0.52	0.60	0.24	0.73			0.64	0.73	0.28		
5700	0.54			0.44	0.54	0.20	0.66			0.53	0.66	0.24		
6000	0.49				0.49	0.17	0.59			0.43	0.59	0.21		
6300	0.44				0.44	0.15	0.54				0.53	0.18		
6600	0.40					0.13	0.49				0.46	0.15		

Span mm	Z/C 10015 (kN/m)						Z/C 10019 (kN/m)							
	INWARD		OUTWARD				L/150	INWARD		OUTWARD				L/150
	0	1, 2, 3	0	1	2	3		0	1, 2, 3	0	1	2	3	
2100	6.20	6.30	5.35	6.30	6.30	6.30	5.71	8.44	8.79	7.37	8.79	8.79	8.79	7.34
2400	4.67	4.83	3.62	4.83	4.83	4.83	3.89	6.30	6.73	4.90	6.73	6.73	6.73	4.99
2700	3.65	3.81	2.47	3.81	3.81	3.81	2.74	4.88	5.32	3.35	5.32	5.32	5.32	3.50
3000	2.92	3.09	1.73	2.99	3.09	3.09	2.01	3.89	4.31	2.34	4.24	4.31	4.31	2.55
3300	2.39	2.55	1.26	2.35	2.55	2.55	1.52	3.17	3.56	1.70	3.32	3.56	3.56	1.92
3600	2.00	2.15	0.93	1.87	2.15	2.15	1.18	2.63	2.99	1.27	2.61	2.99	2.99	1.48
3900	1.69	1.83	0.71	1.51	1.83	1.83	0.93	2.22	2.55	0.97	2.08	2.55	2.55	1.16
4200	1.45	1.58	0.55	1.20	1.56	1.58	0.74	1.89	2.20	0.76	1.65	2.20	2.20	0.93
4500	1.25	1.37	0.43	0.97	1.31	1.37	0.60	1.64	1.91	0.61	1.32	1.87	1.91	0.76
4800	1.10	1.21		0.78	1.12	1.21	0.50	1.43	1.68	0.50	1.06	1.58	1.68	0.62
5100	0.97	1.07		0.63	0.96	1.07	0.42	1.26	1.49	0.41	0.86	1.34	1.49	0.52
5400	0.86	0.95		0.52	0.82	0.95	0.35	1.11	1.33		0.71	1.14	1.33	0.44
5700	0.77	0.86		0.43	0.71	0.84	0.30	0.99	1.19		0.58	0.98	1.19	0.37
6000	0.69	0.77			0.61	0.74	0.26	0.89	1.08		0.49	0.84	1.05	0.32
6300	0.62	0.70			0.52	0.65	0.22	0.81	0.98		0.41	0.71	0.93	0.28
6600	0.57	0.64			0.45	0.58	0.19	0.73	0.89			0.61	0.82	0.24
6900	0.52	0.58				0.52	0.17	0.67	0.81			0.53	0.72	0.21
7200	0.47	0.54				0.46	0.15	0.61	0.75			0.46	0.64	0.19
7500	0.44	0.49					0.13	0.56	0.56				0.57	0.16

Bold capacities require grade 8.8 purlin bolts.

Values above dotted horizontal line in body of table are governed by the strength of the grade 8.8 bolt.

INWARD = Inward load capacity. OUTWARD = Outward load capacity. L/150 = Load for deflection span/150.

See also: Design notes for capacity tables.

Single Spans

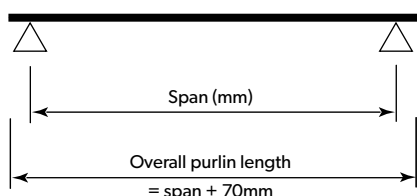

SINGLE SPANS

Span mm	Z/C 15012 (kN/m)							L/150	Z/C 15015 (kN/m)							L/150
	INWARD			OUTWARD					INWARD			OUTWARD				
	0	1, 2, 3		0	1	2	3		0	1, 2, 3		0	1	2	3	
2100	8.46	8.46		8.46	8.46	8.46	8.46	11.50	11.12	11.12		11.12	11.12	11.12	11.12	15.62
2400	6.48	6.48		6.40	6.48	6.48	6.48	7.88	8.51	8.51		8.17	8.51	8.51	8.51	10.50
2700	5.12	5.12		4.45	5.12	5.12	5.12	5.73	6.73	6.73		5.79	6.73	6.73	6.73	7.48
3000	4.15	4.15		3.14	4.15	4.15	4.15	4.28	5.41	5.45		4.02	5.45	5.45	5.45	5.52
3300	3.43	3.43		2.28	3.43	3.43	3.43	3.26	4.39	4.50		3.00	4.50	4.50	4.50	4.19
3600	2.88	2.88		1.70	2.88	2.88	2.88	2.53	3.64	3.78		2.29	3.78	3.78	3.78	3.27
3900	2.45	2.45		1.27	2.45	2.45	2.45	2.01	3.06	3.22		1.75	3.22	3.22	3.22	2.61
4200	2.12	2.12		1.01	2.12	2.12	2.12	1.63	2.61	2.78		1.36	2.73	2.78	2.78	2.12
4500	1.84	1.84		0.81	1.76	1.84	1.84	1.33	2.25	2.42		1.06	2.25	2.42	2.42	1.74
4800	1.62	1.62		0.65	1.42	1.62	1.62	1.11	1.96	2.13		0.84	1.85	2.13	2.13	1.45
5100	1.44	1.44		0.52	1.16	1.44	1.44	0.93	1.72	1.89		0.67	1.52	1.89	1.89	1.21
5400	1.28	1.28		0.42	0.95	1.28	1.28	0.79	1.52	1.68		0.55	1.23	1.68	1.68	1.03
5700	1.15	1.15			0.79	1.15	1.15	0.68	1.36	1.51		0.45	1.04	1.51	1.51	0.88
6000	1.03	1.04			0.67	1.04	1.04	0.58	1.21	1.36			0.89	1.36	1.36	0.76
6300	0.93	0.94			0.56	0.93	0.94	0.51	1.09	1.24			0.76	1.19	1.24	0.66
6600	0.84	0.86			0.48	0.82	0.86	0.45	0.98	1.13			0.65	1.05	1.13	0.57
6900	0.77	0.78			0.41	0.71	0.78	0.39	0.89	1.03			0.56	0.92	1.03	0.50
7200	0.70	0.72				0.61	0.72	0.35	0.82	0.95			0.48	0.80	0.95	0.44
7500	0.65	0.66				0.54	0.66	0.31	0.75	0.87			0.42	0.70	0.87	0.39

Span mm	Z/C 15019 (kN/m)							L/150	Z/C 15024 (kN/m)							L/150
	INWARD			OUTWARD					INWARD			OUTWARD				
	0	1	2, 3	0	1	2	3		0	1	2, 3	0	1	2	3	
3000	6.79	7.68	7.68	5.67	7.68	7.68	7.68	7.33	8.82	10.82	10.82	7.71	10.82	10.82	10.82	9.58
3300	5.51	6.35	6.35	4.12	6.35	6.35	6.35	5.59	7.04	8.94	8.94	5.54	8.94	8.94	8.94	7.22
3600	4.56	5.33	5.33	3.09	5.33	5.33	5.33	4.32	5.70	7.52	7.52	4.09	7.52	7.52	7.52	5.56
3900	3.82	4.55	4.55	2.32	4.37	4.55	4.55	3.42	4.71	6.40	6.40	3.09	6.20	6.40	6.40	4.37
4200	3.24	3.92	3.92	1.78	3.62	3.92	3.92	2.76	3.95	5.52	5.52	2.39	5.09	5.52	5.52	3.50
4500	2.78	3.41	3.41	1.39	3.02	3.41	3.41	2.26	3.36	4.81	4.81	1.88	4.22	4.81	4.81	2.85
4800	2.41	3.00	3.00	1.11	2.53	3.00	3.00	1.86	2.89	4.23	4.23	1.51	3.52	4.23	4.23	2.35
5100	2.11	2.66	2.66	0.90	2.10	2.66	2.66	1.55	2.52	3.74	3.74	1.23	2.93	3.74	3.74	1.96
5400	1.87	2.37	2.37	0.73	1.75	2.35	2.37	1.31	2.21	3.34	3.34	1.01	2.40	3.34	3.34	1.65
5700	1.66	2.13	2.13	0.61	1.45	2.05	2.13	1.11	1.95	2.98	3.00	0.84	1.98	2.91	3.00	1.40
6000	1.48	1.92	1.92	0.51	1.22	1.80	1.92	0.95	1.74	2.66	2.71	0.71	1.65	2.54	2.71	1.20
6300	1.33	1.74	1.74	0.43	1.04	1.59	1.74	0.82	1.56	2.39	2.45	0.61	1.39	2.23	2.45	1.04
6600	1.20	1.59	1.59		0.88	1.41	1.59	0.72	1.41	2.16	2.24	0.52	1.18	1.97	2.24	0.90
6900	1.09	1.45	1.45		0.75	1.25	1.45	0.63	1.27	1.96	2.05	0.45	1.01	1.74	2.05	0.79
7200	0.99	1.33	1.33		0.64	1.10	1.32	0.55	1.16	1.79	1.88		0.86	1.54	1.88	0.70
7500	0.91	1.22	1.23		0.55	0.97	1.20	0.49	1.06	1.64	1.73		0.75	1.35	1.70	0.62
7800	0.83	1.12	1.14		0.48	0.86	1.08	0.43	0.97	1.50	1.60		0.65	1.18	1.53	0.55
8100	0.77	1.04	1.05		0.42	0.75	0.98	0.39	0.89	1.38	1.48		0.57	1.03	1.39	0.49

Bold capacities require grade 8.8 purlin bolts.

Values above dotted horizontal line in body of table are governed by the strength of the grade 8.8 bolt.

INWARD = Inward load capacity. OUTWARD = Outward load capacity. L/150 = Load for deflection span/150.

See also: Design notes for capacity tables.

Single Spans

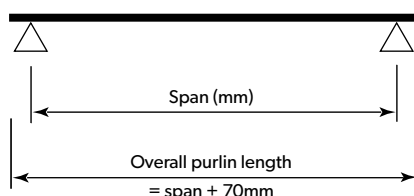

Bridging > Span mm	Z/C 20015 (kN/m)							Z/C 20019 (kN/m)								
	INWARD			OUTWARD				L/150	INWARD			OUTWARD				L/150
	0	1, 2, 3		0	1	2	3		0	1, 2, 3	0	1	2	3		
3000	7.38	7.38		7.28	7.38	7.38	7.38	10.60	10.52	11.25	10.56	11.25	11.25	11.25	15.10	
3300	6.10	6.10		5.47	6.10	6.10	6.10	7.96	8.38	9.30	7.83	9.30	9.30	9.30	11.42	
3600	5.13	5.13		4.10	5.13	5.13	5.13	6.28	6.78	7.81	5.77	7.81	7.81	7.81	8.89	
3900	4.33	4.37		3.13	4.37	4.37	4.37	5.07	5.59	6.66	4.50	6.66	6.66	6.66	7.06	
4200	3.69	3.77		2.44	3.77	3.77	3.77	4.15	4.54	5.74	3.57	5.74	5.74	5.74	5.70	
4500	3.17	3.28		1.86	3.28	3.28	3.28	3.45	3.88	5.00	2.84	5.00	5.00	5.00	4.67	
4800	2.75	2.88		1.51	2.88	2.88	2.88	2.88	3.35	4.39	2.27	4.39	4.39	4.39	3.88	
5100	2.41	2.56		1.25	2.56	2.56	2.56	2.42	2.92	3.89	1.84	3.84	3.89	3.89	3.27	
5400	2.13	2.28		1.04	2.24	2.28	2.28	2.05	2.57	3.47	1.51	3.27	3.47	3.47	2.78	
5700	1.89	2.05		0.87	1.92	2.05	2.05	1.75	2.27	3.12	1.24	2.77	3.12	3.12	2.39	
6000	1.68	1.85		0.72	1.62	1.85	1.85	1.51	2.03	2.81	1.03	2.26	2.81	2.81	2.07	
6300	1.51	1.67		0.61	1.38	1.67	1.67	1.31	1.82	2.55	0.86	1.94	2.55	2.55	1.80	
6600	1.36	1.53		0.52	1.18	1.53	1.53	1.15	1.64	2.32	0.72	1.68	2.32	2.32	1.57	
6900	1.23	1.40		0.44	1.01	1.40	1.40	1.01	1.49	2.13	0.62	1.46	2.13	2.13	1.38	
7200	1.12	1.28			0.87	1.28	1.28	0.89	1.36	1.95	0.53	1.28	1.95	1.95	1.22	
7500	1.03	1.18			0.76	1.18	1.18	0.79	1.24	1.80	0.46	1.12	1.78	1.80	1.08	
7800	0.94	1.09			0.64	1.09	1.09	0.71	1.14	1.66	0.40	0.99	1.59	1.66	0.96	
8100	0.87	1.01			0.56	0.98	1.01	0.64	1.05	1.54		0.86	1.43	1.54	0.86	
8400	0.80	0.94			0.50	0.88	0.94	0.58	0.97	1.44		0.76	1.27	1.44	0.77	
8700	0.74	0.88			0.45	0.79	0.88	0.52	0.90	1.34		0.67	1.13	1.34	0.70	
9000	0.69	0.82			0.40	0.70	0.82	0.47	0.84	1.25		0.60	0.98	1.25	0.63	
9300	0.64	0.77				0.63	0.77	0.43	0.78	1.17		0.53	0.89	1.17	0.58	
9600	0.60	0.72				0.56	0.72	0.39	0.73	1.10		0.47	0.80	1.10	0.52	
9900	0.56	0.68				0.51	0.68	0.36	0.68	1.03		0.42	0.73	1.03	0.48	
10200	0.53	0.64				0.46	0.64	0.33	0.64	0.97			0.66	0.95	0.44	
10500	0.49	0.60				0.42	0.60	0.31	0.60	0.92			0.61	0.87	0.40	
10800	0.46	0.57					0.55	0.28	0.56	0.87			0.55	0.80	0.37	
11100	0.44	0.54					0.51	0.26	0.53	0.82			0.51	0.74	0.34	
11400	0.41	0.51						0.24	0.50	0.78			0.47	0.68	0.31	
11700	0.39	0.49						0.22	0.48	0.74			0.43	0.62	0.29	
12000	0.37	0.46						0.21	0.45	0.70				0.55	0.27	

Bridging > Span mm	Z/C 20024 (kN/m)								L/150
	INWARD				OUTWARD				
	0	1	2	3	0	1	2	3	
3000	13.70	16.35	16.35	16.35	14.57	16.35	16.35	16.35	19.93
3300	10.79	13.52	13.52	13.52	11.11	13.52	13.52	13.52	15.19
3600	8.65	11.36	11.36	11.36	8.32	11.36	11.36	11.36	11.89
3900	7.08	9.68	9.68	9.68	6.38	9.68	9.68	9.68	9.49
4200	5.91	8.34	8.34	8.34	4.95	8.34	8.34	8.34	7.67
4500	5.00	7.27	7.27	7.27	3.86	7.23	7.27	7.27	6.27
4800	4.29	6.39	6.39	6.39	3.06	6.14	6.39	6.39	5.19
5100	3.72	5.66	5.66	5.66	2.46	5.26	5.66	5.66	4.35
5400	3.26	5.05	5.05	5.05	2.00	4.53	5.05	5.05	3.69
5700	2.88	4.53	4.53	4.53	1.65	3.91	4.53	4.53	3.15
6000	2.55	4.05	4.09	4.09	1.38	3.35	4.09	4.09	2.70
6300	2.28	3.64	3.71	3.71	1.16	2.84	3.71	3.71	2.34
6600	2.04	3.28	3.38	3.38	0.98	2.43	3.36	3.38	2.03
6900	1.84	2.98	3.09	3.09	0.84	2.09	3.01	3.09	1.78
7200	1.67	2.71	2.84	2.84	0.72	1.82	2.70	2.84	1.57
7500	1.52	2.48	2.62	2.62	0.63	1.57	2.43	2.62	1.38
7800	1.39	2.27	2.42	2.42	0.55	1.36	2.20	2.42	1.23
8100	1.28	2.09	2.24	2.24	0.48	1.19	1.99	2.24	1.10
8400	1.18	1.93	2.09	2.09	0.42	1.04	1.80	2.09	0.99
8700	1.09	1.79	1.95	1.95		0.91	1.62	1.95	0.89
9000	1.01	1.66	1.82	1.82		0.81	1.45	1.79	0.80
9300	0.93	1.55	1.70	1.70		0.72	1.30	1.65	0.73
9600	0.87	1.44	1.60	1.60		0.64	1.17	1.52	0.66
9900	0.81	1.35	1.49	1.50		0.57	1.05	1.41	0.60
10200	0.76	1.27	1.40	1.42		0.51	0.95	1.30	0.55
10500	0.71	1.19	1.31	1.34		0.46	0.86	1.21	0.50
10800	0.67	1.12	1.23	1.26		0.41	0.78	1.12	0.46
11100	0.63	1.06	1.16	1.20			0.71	1.04	0.43
11400	0.59	1.00	1.09	1.13			0.64	0.96	0.39
11700	0.56	0.94	1.03	1.08			0.59	0.89	0.37
12000	0.53	0.89	0.98	1.02			0.53	0.82	0.34

Bold capacities require grade 8.8 purlin bolts.
 Values above dotted horizontal line in body of table are governed by the strength of the grade 8.8 bolt.
 INWARD = Inward load capacity. OUTWARD = Outward load capacity. L/150 = Load for deflection span/150.
 See also: Design notes for capacity tables.

Single Spans

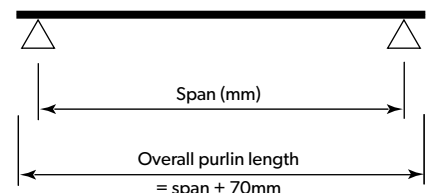

Bridging > Span mm	Z/C 25019 (kN/m)							Z/C 25024 (kN/m)								
	INWARD			OUTWARD				L/150	INWARD			OUTWARD				L/150
	0	1, 2, 3		0	1	2	3		0	1	2, 3	0	1	2	3	
3000	13.83	14.28		14.17	14.28	14.28	14.28	24.52	17.71	20.96	20.96	19.42	20.96	20.96	20.96	33.82
3300	10.90	11.80		10.06	11.80	11.80	11.80	18.42	13.78	17.32	17.32	14.58	17.32	17.32	17.32	25.41
3600	8.51	9.92		7.64	9.92	9.92	9.92	14.19	11.02	14.56	14.56	10.84	14.56	14.56	14.56	19.57
3900	7.04	8.45		5.92	8.45	8.45	8.45	11.16	9.01	12.40	12.40	8.29	12.40	12.40	12.40	15.46
4200	5.91	7.28		4.67	7.28	7.28	7.28	9.07	7.50	10.69	10.69	6.39	10.69	10.69	10.69	12.53
4500	5.04	6.35		3.69	6.35	6.35	6.35	7.54	6.34	9.32	9.32	4.97	9.32	9.32	9.32	10.30
4800	4.34	5.58		2.93	5.58	5.58	5.58	6.35	5.43	8.19	8.19	3.93	8.19	8.19	8.19	8.58
5100	3.78	4.94		2.37	4.94	4.94	4.94	5.38	4.71	7.25	7.25	3.15	7.03	7.25	7.25	7.22
5400	3.32	4.41		1.94	4.39	4.41	4.41	4.56	4.11	6.47	6.47	2.55	6.03	6.47	6.47	6.11
5700	2.94	3.96		1.58	3.68	3.96	3.96	3.90	3.61	5.81	5.81	2.10	5.16	5.81	5.81	5.21
6000	2.62	3.57		1.31	3.01	3.57	3.57	3.37	3.19	5.24	5.24	1.74	4.38	5.24	5.24	4.48
6300	2.35	3.24		1.09	2.58	3.24	3.24	2.93	2.85	4.75	4.75	1.46	3.70	4.75	4.75	3.89
6600	2.12	2.95		0.92	2.22	2.95	2.95	2.57	2.55	4.33	4.33	1.23	3.16	4.33	4.33	3.40
6900	1.92	2.70		0.78	1.92	2.70	2.70	2.26	2.30	3.96	3.96	1.05	2.72	3.96	3.96	2.99
7200	1.75	2.48		0.67	1.68	2.48	2.48	2.00	2.08	3.60	3.64	0.90	2.35	3.62	3.64	2.64
7500	1.60	2.28		0.57	1.47	2.28	2.28	1.78	1.90	3.29	3.35	0.78	2.03	3.25	3.35	2.34
7800	1.46	2.11		0.50	1.29	2.11	2.11	1.60	1.73	3.01	3.10	0.68	1.75	2.93	3.10	2.08
8100	1.35	1.96		0.43	1.12	1.91	1.96	1.43	1.59	2.77	2.88	0.59	1.53	2.64	2.88	1.86
8400	1.24	1.82			0.98	1.69	1.82	1.29	1.46	2.56	2.67	0.52	1.33	2.37	2.67	1.67
8700	1.15	1.70			0.87	1.46	1.70	1.16	1.35	2.36	2.49	0.46	1.17	2.12	2.49	1.50
9000	1.07	1.59			0.77	1.31	1.59	1.05	1.25	2.19	2.33	0.41	1.03	1.89	2.33	1.36
9300	1.00	1.49			0.69	1.18	1.49	0.95	1.16	2.04	2.18		0.91	1.69	2.18	1.23
9600	0.93	1.39			0.61	1.06	1.39	0.87	1.08	1.90	2.05		0.81	1.52	2.04	1.12
9900	0.87	1.31			0.54	0.96	1.31	0.79	1.01	1.78	1.93		0.72	1.36	1.88	1.02
10200	0.82	1.24			0.49	0.87	1.24	0.73	0.94	1.67	1.81		0.65	1.23	1.74	0.93
10500	0.77	1.17			0.44	0.80	1.17	0.67	0.88	1.56	1.71		0.58	1.12	1.61	0.85
10800	0.72	1.10				0.73	1.07	0.61	0.83	1.47	1.62		0.52	1.01	1.49	0.78
11100	0.68	1.04				0.66	0.98	0.57	0.78	1.38	1.53		0.47	0.92	1.37	0.72
11400	0.64	0.99				0.61	0.90	0.53	0.74	1.30	1.45		0.43	0.83	1.26	0.67
11700	0.61	0.94				0.55	0.80	0.49	0.69	1.23	1.38			0.75	1.16	0.62
12000	0.58	0.89				0.50	0.74	0.45	0.66	1.16	1.30			0.69	1.07	0.57

Bold capacities require grade 8.8 purlin bolts.

Values above dotted horizontal line in body of table are governed by the strength of the grade 8.8 bolt.

INWARD = Inward load capacity. OUTWARD = Outward load capacity. L/150 = Load for deflection span/150.

See also: Design notes for capacity tables.

Single Spans

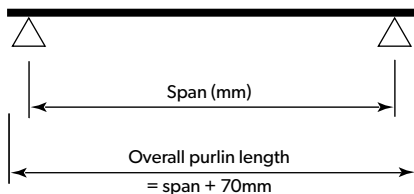

Bridging > Span mm	Z/C 30024 (kN/m)								L/150	Z/C 30030 (kN/m)								L/150
	INWARD				OUTWARD					INWARD				OUTWARD				
	0	1	2	3	0	1	2	3		0	1	2	3	0	1	2	3	
6000	4.50	7.20	7.20	7.20	3.84	7.20	7.20	7.20	7.44	5.21	10.26	10.26	10.26	5.04	10.26	10.26	10.26	9.95
6300	3.99	6.53	6.53	6.53	3.21	6.53	6.53	6.53	6.46	4.59	9.31	9.31	9.31	4.22	9.11	9.31	9.31	8.64
6600	3.57	5.95	5.95	5.95	2.70	5.93	5.95	5.95	5.65	4.06	8.46	8.48	8.48	3.56	8.09	8.48	8.48	7.56
6900	3.21	5.44	5.44	5.44	2.29	5.24	5.44	5.44	4.97	3.63	7.63	7.76	7.76	3.03	7.21	7.76	7.76	6.66
7200	2.89	5.00	5.00	5.00	1.96	4.61	5.00	5.00	4.40	3.25	6.91	7.13	7.13	2.59	6.44	7.13	7.13	5.86
7500	2.61	4.61	4.61	4.61	1.68	4.03	4.61	4.61	3.93	2.94	6.29	6.57	6.57	2.23	5.74	6.57	6.57	5.18
7800	2.37	4.26	4.26	4.26	1.45	3.54	4.26	4.26	3.52	2.66	5.74	6.07	6.07	1.94	5.05	6.07	6.07	4.61
8100	2.17	3.95	3.95	3.95	1.27	3.08	3.95	3.95	3.17	2.43	5.26	5.63	5.63	1.69	4.47	5.63	5.63	4.12
8400	1.99	3.67	3.67	3.67	1.11	2.75	3.67	3.67	2.86	2.22	4.83	5.24	5.24	1.48	3.95	5.24	5.24	3.69
8700	1.83	3.40	3.42	3.42	0.97	2.47	3.42	3.42	2.60	2.04	4.45	4.88	4.88	1.30	3.48	4.88	4.88	3.32
9000	1.68	3.14	3.20	3.20	0.86	2.22	3.20	3.20	2.35	1.88	4.11	4.56	4.56	1.15	3.07	4.53	4.56	3.00
9300	1.56	2.91	3.00	3.00	0.76	2.01	3.00	3.00	2.14	1.73	3.80	4.27	4.27	1.02	2.73	4.17	4.27	2.72
9600	1.45	2.70	2.81	2.81	0.68	1.80	2.81	2.81	1.95	1.61	3.52	4.01	4.01	0.91	2.43	3.85	4.01	2.47
9900	1.35	2.51	2.64	2.64	0.61	1.62	2.60	2.64	1.79	1.49	3.26	3.77	3.77	0.82	2.17	3.56	3.77	2.25
10200	1.25	2.34	2.49	2.49	0.54	1.47	2.39	2.49	1.64	1.39	3.02	3.55	3.55	0.74	1.94	3.29	3.55	2.06
10500	1.17	2.18	2.35	2.35	0.49	1.32	2.19	2.35	1.50	1.30	2.80	3.35	3.35	0.67	1.74	3.05	3.35	1.89
10800	1.10	2.04	2.22	2.22	0.44	1.18	2.00	2.22	1.38	1.22	2.61	3.16	3.17	0.60	1.57	2.82	3.17	1.74
11100	1.03	1.91	2.10	2.10	0.40	1.07	1.83	2.10	1.27	1.14	2.44	2.97	3.00	0.55	1.42	2.60	3.00	1.60
11400	0.97	1.79	1.99	1.99	0.37	0.97	1.67	1.99	1.18	1.07	2.28	2.79	2.84	0.50	1.29	2.39	2.84	1.48
11700	0.91	1.68	1.89	1.89	0.34	0.88	1.53	1.89	1.09	1.01	2.14	2.63	2.70	0.46	1.17	2.19	2.70	1.37
12000	0.86	1.58	1.80	1.80	0.31	0.80	1.39	1.80	1.01	0.95	2.01	2.48	2.57	0.42	1.06	2.02	2.55	1.27
Sections below exceed the normal delivery length of 12000mm																		
12300	0.81	1.48	1.71	1.71	0.28	0.73	1.29	1.71	0.94	0.90	1.89	2.34	2.44	0.39	0.97	1.86	2.40	1.18
12600	0.77	1.40	1.63	1.63	0.26	0.66	1.20	1.63	0.87	0.85	1.78	2.21	2.33	0.37	0.89	1.70	2.26	1.09
12900	0.73	1.32	1.56	1.56	0.24	0.61	1.11	1.56	0.81	0.81	1.67	2.10	2.22	0.35	0.81	1.56	2.12	1.02
13200	0.69	1.25	1.49	1.49	0.22	0.56	1.04	1.46	0.76	0.76	1.58	1.99	2.12	0.33	0.75	1.44	2.00	0.95
13500	0.66	1.19	1.42	1.42	0.21	0.51	0.97	1.37	0.71	0.73	1.49	1.89	2.03	0.32	0.69	1.32	1.89	0.89
13800	0.63	1.13	1.36	1.36	0.20	0.47	0.90	1.29	0.66	0.69	1.41	1.79	1.94	0.31	0.63	1.22	1.78	0.83
14100	0.60	1.07	1.30	1.30	0.19	0.43	0.84	1.21	0.62	0.66	1.34	1.71	1.86	0.30	0.58	1.13	1.68	0.78
14400	0.57	1.02	1.25	1.25	0.18	0.40	0.78	1.13	0.58	0.63	1.27	1.62	1.78	0.29	0.54	1.04	1.59	0.73
14700	0.54	0.97	1.19	1.20	0.17	0.37	0.73	1.05	0.55	0.60	1.20	1.55	1.71	0.28	0.50	0.97	1.50	0.69
15000	0.52	0.91	1.13	1.15	0.16	0.34	0.68	0.98	0.52	0.57	1.15	1.48	1.63	0.27	0.47	0.90	1.40	0.65
15300	0.50	0.87	1.08	1.11	0.15	0.33	0.63	0.92	0.49	0.55	1.09	1.41	1.56	0.26	0.43	0.83	1.32	0.61
15600	0.48	0.83	1.03	1.07	0.14	0.31	0.59	0.86	0.46	0.52	1.04	1.35	1.49	0.25	0.40	0.78	1.23	0.58
15900	0.46	0.80	0.99	1.03	0.13	0.30	0.54	0.80	0.43	0.50	0.99	1.29	1.43	0.24	0.38	0.72	1.16	0.54
16200	0.44	0.77	0.95	0.99	0.12	0.29	0.51	0.75	0.41	0.48	0.95	1.23	1.37	0.23	0.37	0.68	1.09	0.51
16500	0.42	0.73	0.91	0.95	0.11	0.28	0.47	0.71	0.39	0.46	0.91	1.17	1.31	0.22	0.36	0.63	1.02	0.49
16800	0.40	0.71	0.87	0.92	0.10	0.27	0.44	0.67	0.37	0.44	0.87	1.12	1.26	0.21	0.35	0.59	0.96	0.46
17100	0.39	0.68	0.84	0.89	0.09	0.26	0.41	0.64	0.35	0.43	0.83	1.07	1.21	0.20	0.34	0.55	0.90	0.44
17400	0.38	0.65	0.80	0.86	0.08	0.25	0.39	0.60	0.33	0.41	0.80	1.03	1.16	0.19	0.33	0.52	0.84	0.42
17700	0.37	0.63	0.77	0.83	0.07	0.24	0.37	0.57	0.31	0.40	0.76	0.98	1.11	0.18	0.32	0.49	0.79	0.39
18000	0.36	0.60	0.74	0.80	0.06	0.23	0.35	0.54	0.30	0.39	0.73	0.94	1.07	0.17	0.31	0.46	0.75	0.38

Bold capacities require grade 8.8 purlin bolts.

Values above dotted horizontal line in body of table are governed by the strength of the grade 8.8 bolt.

INWARD = Inward load capacity. OUTWARD = Outward load capacity. L/150 = Load for deflection span/150.

See also: Design notes for capacity tables.

Single Spans

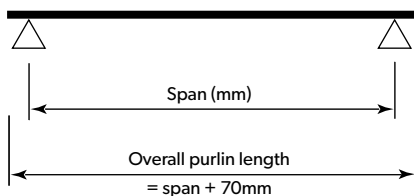

Bridging > Span mm	Z/C 35030 (kN/m)								L/150
	INWARD				OUTWARD				
	0	1	2	3	0	1	2	3	
6000	7.46	12.56	12.56	12.56	9.16	12.56	12.56	12.56	15.01
6300	6.57	11.39	11.39	11.39	7.66	11.39	11.39	11.39	13.05
6600	5.78	10.38	10.38	10.38	6.63	10.38	10.38	10.38	11.41
6900	5.13	9.50	9.50	9.50	5.78	9.50	9.50	9.50	10.04
7200	4.58	8.72	8.72	8.72	5.06	8.72	8.72	8.72	8.89
7500	4.11	8.04	8.04	8.04	4.39	8.04	8.04	8.04	7.90
7800	3.72	7.43	7.43	7.43	3.83	7.43	7.43	7.43	7.06
8100	3.37	6.89	6.89	6.89	3.37	6.89	6.89	6.89	6.33
8400	3.08	6.41	6.41	6.41	2.97	6.36	6.41	6.41	5.70
8700	2.82	5.97	5.97	5.97	2.61	5.76	5.97	5.97	5.15
9000	2.58	5.58	5.58	5.58	2.30	5.23	5.58	5.58	4.67
9300	2.37	5.14	5.23	5.23	2.04	4.71	5.23	5.23	4.25
9600	2.18	4.75	4.91	4.91	1.81	4.24	4.91	4.91	3.89
9900	2.02	4.40	4.61	4.61	1.62	3.83	4.61	4.61	3.56
10200	1.87	4.08	4.35	4.35	1.45	3.47	4.35	4.35	3.28
10500	1.74	3.78	4.10	4.10	1.30	3.15	4.10	4.10	3.02
10800	1.62	3.50	3.88	3.88	1.17	2.86	3.88	3.88	2.79
11100	1.52	3.25	3.67	3.67	1.06	2.55	3.67	3.67	2.59
11400	1.42	3.03	3.48	3.48	0.96	2.35	3.48	3.48	2.40
11700	1.33	2.82	3.30	3.30	0.87	2.17	3.30	3.30	2.23
12000	1.25	2.64	3.14	3.14	0.80	2.00	3.14	3.14	2.07
Sections below exceed the normal delivery length of 12000mm									
12300	1.18	2.47	2.99	2.99	0.73	1.85	2.97	2.99	1.93
12600	1.11	2.32	2.85	2.85	0.67	1.72	2.78	2.85	1.80
12900	1.05	2.18	2.72	2.72	0.61	1.60	2.6	2.72	1.68
13200	0.99	2.05	2.60	2.60	0.56	1.48	2.44	2.6	1.57
13500	0.94	1.93	2.48	2.48	0.52	1.37	2.27	2.48	1.47
13800	0.89	1.82	2.37	2.37	0.48	1.26	2.11	2.37	1.38
14100	0.85	1.73	2.27	2.27	0.44	1.17	1.97	2.27	1.29
14400	0.8	1.63	2.18	2.18	0.41	1.09	1.84	2.18	1.22
14700	0.77	1.55	2.09	2.09		1.02	1.72	2.09	1.15
15000	0.73	1.47	1.99	2.01		0.95	1.6	2.01	1.08
15300	0.7	1.36	1.90	1.93		0.88	1.5	1.93	1.02
15600	0.67	1.3	1.8	1.86		0.82	1.41	1.86	0.97
15900	0.64	1.24	1.72	1.79		0.76	1.32	1.79	0.91
16200	0.6	1.19	1.65	1.72		0.71	1.21	1.72	0.86
16500	0.59	1.13	1.57	1.66		0.66	1.14	1.65	0.82
16800	0.56	1.09	1.50	1.60		0.62	1.08	1.57	0.77
17100	0.54	1.04	1.44	1.55		0.58	1.02	1.49	0.73
17400	0.52	1.00	1.37	1.49		0.54	0.97	1.42	0.70
17700	0.50	0.96	1.31	1.44		0.51	0.92	1.35	0.66
18000	0.48	0.92	1.25	1.40		0.48	0.87	1.28	0.63

Bold capacities require grade 8.8 purlin bolts.

Values above dotted horizontal line in body of table are governed by the strength of the grade 8.8 bolt.

INWARD = Inward load capacity. OUTWARD = Outward load capacity. L/150 = Load for deflection span/150.

See also: Design notes for capacity tables.

Single Spans

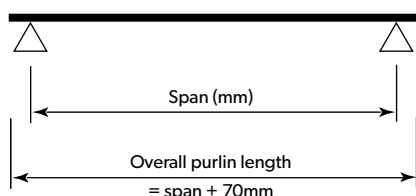

Bridging > Span mm	Z/C 10010 (kN/m)							Z/C 10012 (kN/m)								
	INWARD			OUTWARD				L/150	INWARD			OUTWARD				L/150
	0	1, 2, 3	0	1	2	3	0		1, 2, 3	0	1	2	3			
2100	3.97	3.97	3.97	3.97	3.97	3.97	8.09	4.84	4.84	4.84	4.84	4.84	4.84	9.97		
2400	3.04	3.04	3.04	3.04	3.04	3.04	5.42	3.70	3.70	3.70	3.70	3.70	3.70	6.68		
2700	2.40	2.40	2.40	2.40	2.40	2.40	3.81	2.93	2.93	2.93	2.93	2.93	2.93	4.69		
3000	1.95	1.95	1.95	1.95	1.95	1.95	2.77	2.37	2.37	2.37	2.37	2.37	2.37	3.42		
3300	1.61	1.61	1.61	1.61	1.61	1.61	2.09	1.96	1.96	1.96	1.96	1.96	1.96	2.57		
3600	1.35	1.35	1.35	1.35	1.35	1.35	1.63	1.65	1.65	1.61	1.65	1.65	1.65	1.99		
3900	1.15	1.15	1.08	1.15	1.15	1.15	1.29	1.40	1.40	1.29	1.40	1.40	1.40	1.58		
4200	0.99	0.99	0.86	0.99	0.99	0.99	1.05	1.19	1.21	1.04	1.21	1.21	1.21	1.28		
4500	0.87	0.87	0.69	0.87	0.87	0.87	0.86	1.02	1.05	0.84	1.05	1.05	1.05	1.05		
4800	0.76	0.76	0.56	0.76	0.76	0.76	0.71	0.88	0.93	0.66	0.93	0.93	0.93	0.87		
5100	0.67	0.67	0.46	0.67	0.67	0.67	0.60	0.76	0.82	0.55	0.82	0.82	0.82	0.73		
5400	0.58	0.60		0.59	0.60	0.60	0.51	0.67	0.73	0.46	0.70	0.73	0.73	0.62		
5700	0.51	0.54		0.50	0.54	0.54	0.43	0.59	0.66		0.61	0.66	0.66	0.53		
6000	0.45	0.49		0.43	0.49	0.49	0.37	0.52	0.59		0.52	0.59	0.59	0.46		

Bridging > Span mm	Z/C 10015 (kN/m)							Z/C 10019 (kN/m)								
	INWARD			OUTWARD				L/150	INWARD			OUTWARD				L/150
	0	1, 2, 3	0	1	2	3	0		1, 2, 3	0	1	2	3			
2100	6.30	6.30	6.30	6.30	6.30	6.30	13.04	8.68	8.79	8.79	8.79	8.79	8.79	17.31		
2400	4.74	4.83	4.83	4.83	4.83	4.83	8.74	6.50	6.73	6.73	6.73	6.73	6.73	11.59		
2700	3.68	3.81	3.81	3.81	3.81	3.81	6.14	5.02	5.32	5.32	5.32	5.32	5.32	8.14		
3000	2.94	3.09	3.09	3.09	3.09	3.09	4.47	3.97	4.31	4.31	4.31	4.31	4.31	5.94		
3300	2.39	2.55	2.46	2.55	2.55	2.55	3.36	3.22	3.56	3.49	3.56	3.56	3.56	4.46		
3600	1.98	2.15	1.99	2.15	2.15	2.15	2.59	2.66	2.99	2.81	2.99	2.99	2.99	3.44		
3900	1.67	1.83	1.63	1.83	1.83	1.83	2.05	2.22	2.55	2.28	2.55	2.55	2.55	2.72		
4200	1.42	1.58	1.35	1.58	1.58	1.58	1.66	1.89	2.20	1.87	2.20	2.20	2.20	2.18		
4500	1.22	1.37	1.12	1.37	1.37	1.37	1.37	1.62	1.91	1.55	1.91	1.91	1.91	1.78		
4800	1.06	1.21	0.93	1.18	1.21	1.21	1.14	1.40	1.68	1.28	1.67	1.68	1.68	1.47		
5100	0.92	1.07	0.78	1.01	1.07	1.07	0.96	1.22	1.49	1.07	1.45	1.49	1.49	1.23		
5400	0.81	0.95	0.65	0.88	0.95	0.95	0.82	1.07	1.33	0.90	1.25	1.33	1.33	1.05		
5700	0.72	0.86	0.55	0.77	0.86	0.86	0.70	0.94	1.19	0.76	1.08	1.19	1.19	0.89		
6000	0.64	0.77	0.47	0.67	0.77	0.77	0.60	0.83	1.08	0.65	0.94	1.08	1.08	0.77		

Sections below exceed the normal delivery length of 12000mm

6300	0.57	0.70	0.40	0.59	0.70	0.70	0.52	0.74	0.98	0.56	0.82	0.98	0.98	0.66
6600	0.51	0.64		0.52	0.62	0.64	0.45	0.66	0.89	0.48	0.72	0.89	0.89	0.58
6900	0.46	0.58		0.45	0.56	0.58	0.40	0.59	0.81	0.42	0.63	0.80	0.81	0.50
7200	0.41	0.54		0.40	0.50	0.54	0.35	0.54	0.75		0.55	0.72	0.75	0.44
7500		0.49			0.45	0.49	0.31	0.48	0.69		0.49	0.64	0.69	0.39

Bold capacities require grade 8.8 purlin bolts.

Values above dotted horizontal line in body of table are governed by the strength of the grade 8.8 bolt.

INWARD = Inward load capacity. OUTWARD = Outward load capacity. L/150 = Load for deflection span/150.

See also: Design notes for capacity tables.

Double Continuous Spans

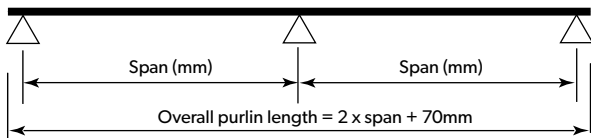

Bridging > Span mm	Z/C 15012 (kN/m)						Z/C 15015 (kN/m)							
	INWARD			OUTWARD			L/150	INWARD			OUTWARD			L/150
	0	1, 2, 3		0	1	2, 3		0	1, 2, 3		0	1	2, 3	
2100	6.43	6.43		6.43	6.43	6.43	27.65	10.29	10.29		10.29	10.29	10.29	37.56
2400	5.32	5.32		5.32	5.32	5.32	18.52	8.28	8.28		8.28	8.28	8.28	25.16
2700	4.47	4.47		4.47	4.47	4.47	13.01	6.73	6.73		6.73	6.73	6.73	17.67
3000	3.80	3.80		3.80	3.80	3.80	9.48	5.45	5.45		5.45	5.45	5.45	12.88
3300	3.27	3.27		3.27	3.27	3.27	7.12	4.48	4.50		4.50	4.50	4.50	9.68
3600	2.83	2.83		2.83	2.83	2.83	5.49	3.69	3.78		3.78	3.78	3.78	7.46
3900	2.45	2.45		2.45	2.45	2.45	4.32	3.09	3.22		3.22	3.22	3.22	5.86
4200	2.12	2.12		2.12	2.12	2.12	3.46	2.62	2.78		2.78	2.78	2.78	4.70
4500	1.84	1.84		1.84	1.84	1.84	2.81	2.24	2.42		2.40	2.42	2.42	3.82
4800	1.61	1.62		1.59	1.62	1.62	2.32	1.94	2.13		2.02	2.13	2.13	3.15
5100	1.41	1.44		1.33	1.44	1.44	1.93	1.69	1.89		1.71	1.89	1.89	2.62
5400	1.24	1.28		1.11	1.28	1.28	1.63	1.48	1.68		1.44	1.68	1.68	2.21
5700	1.09	1.15		0.93	1.15	1.15	1.41	1.30	1.51		1.21	1.51	1.51	1.88
6000	0.97	1.04		0.79	1.04	1.04	1.23	1.15	1.36		1.01	1.36	1.36	1.62

Sections below exceed the normal delivery length of 12000mm

6300	0.86	0.94		0.67	0.94	0.94	1.07	1.02	1.24		0.87	1.24	1.24	1.41
6600	0.76	0.86		0.58	0.86	0.86	0.95	0.91	1.13		0.76	1.13	1.13	1.23
6900	0.68	0.78		0.50	0.78	0.78	0.84	0.80	1.03		0.67	1.00	1.03	1.09
7200	0.62	0.72		0.43	0.70	0.72	0.75	0.72	0.95		0.59	0.89	0.95	0.96
7500	0.55	0.66			0.61	0.66	0.66	0.65	0.87		0.52	0.80	0.87	0.85
7800	0.50	0.61			0.54	0.61	0.59	0.59	0.81		0.45	0.71	0.81	0.76
8100	0.46	0.57			0.48	0.57	0.53	0.54	0.75		0.40	0.63	0.75	0.68

Bridging > Span mm	Z/C 15019 (kN/m)							L/150	Z/C 15024 (kN/m)							L/150
	INWARD			OUTWARD					INWARD			OUTWARD				
	0	1	2, 3	0	1	2	3		0	1	2, 3	0	1	2	3	
3000	7.01	7.68	7.68	7.68	7.68	7.68	7.68	16.81	9.34	10.82	10.82	10.82	10.82	10.82	10.82	22.42
3300	5.67	6.35	6.35	6.35	6.35	6.35	6.35	12.63	7.50	8.94	8.94	8.94	8.94	8.94	8.94	16.84
3600	4.68	5.33	5.33	5.33	5.33	5.33	5.33	9.73	6.13	7.52	7.52	7.52	7.52	7.52	7.52	12.97
3900	3.92	4.55	4.55	4.51	4.55	4.55	4.55	7.65	5.07	6.40	6.40	6.40	6.40	6.40	6.40	10.20
4200	3.32	3.92	3.92	3.76	3.92	3.92	3.92	6.13	4.23	5.52	5.52	5.30	5.52	5.52	5.52	8.17
4500	2.83	3.41	3.41	3.17	3.41	3.41	3.41	4.98	3.57	4.81	4.81	4.43	4.81	4.81	4.81	6.64
4800	2.44	3.00	3.00	2.69	3.00	3.00	3.00	4.10	3.05	4.23	4.23	3.74	4.23	4.23	4.23	5.47
5100	2.12	2.66	2.66	2.30	2.66	2.66	2.66	3.42	2.64	3.74	3.74	3.18	3.74	3.74	3.74	4.56
5400	1.86	2.37	2.37	1.96	2.37	2.37	2.37	2.88	2.30	3.34	3.34	2.72	3.34	3.34	3.34	3.85
5700	1.64	2.13	2.13	1.68	2.13	2.13	2.13	2.47	2.01	3.00	3.00	2.31	3.00	3.00	3.00	3.28
6000	1.45	1.92	1.92	1.43	1.90	1.92	1.92	2.13	1.78	2.71	2.71	1.95	2.71	2.71	2.71	2.82

Sections below exceed the normal delivery length of 12000mm

6300	1.29	1.74	1.74	1.22	1.68	1.74	1.74	1.86	1.58	2.45	2.45	1.67	2.39	2.45	2.45	2.45
6600	1.16	1.59	1.59	1.05	1.50	1.59	1.59	1.63	1.41	2.24	2.24	1.43	2.11	2.24	2.24	2.14
6900	1.04	1.45	1.45	0.91	1.34	1.45	1.45	1.44	1.27	2.05	2.05	1.24	1.88	2.05	2.05	1.88
7200	0.93	1.33	1.33	0.80	1.20	1.33	1.33	1.27	1.15	1.88	1.88	1.08	1.68	1.88	1.88	1.67
7500	0.85	1.23	1.23	0.70	1.07	1.23	1.23	1.14	1.04	1.73	1.73	0.94	1.50	1.73	1.73	1.48
7800	0.77	1.14	1.14	0.62	0.97	1.14	1.14	1.02	0.94	1.60	1.60	0.83	1.35	1.60	1.60	1.31
8100	0.70	1.05	1.05	0.54	0.87	1.05	1.05	0.91	0.86	1.48	1.48	0.74	1.22	1.48	1.48	1.17
8400	0.64	0.98	0.98	0.48	0.78	0.96	0.98	0.82	0.79	1.36	1.38	0.66	1.09	1.37	1.38	1.05
8700	0.59	0.90	0.91	0.43	0.70	0.88	0.91	0.74	0.72	1.25	1.29	0.59	0.97	1.25	1.29	0.95
9000	0.54	0.84	0.85		0.62	0.81	0.85	0.67	0.66	1.16	1.20	0.53	0.87	1.15	1.20	0.86

Bold capacities require grade 8.8 purlin bolts.

Values above dotted horizontal line in body of table are governed by the strength of the grade 8.8 bolt.

INWARD = Inward load capacity. OUTWARD = Outward load capacity. L/150 = Load for deflection span/150.

See also: Design notes for capacity tables.

Double Continuous Spans

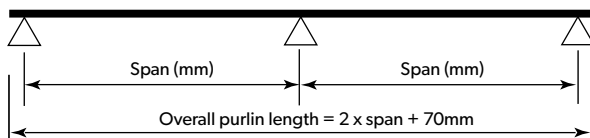

Bridging > Span mm	Z/C 20015 (kN/m)						Z/C 20019 (kN/m)						Z/C 20024 (kN/m)								
	INWARD			OUTWARD			L/150	INWARD			OUTWARD			L/150	INWARD			OUTWARD			L/150
	0	1, 2, 3	0	1	2, 3	0		1, 2, 3	0	1	2, 3	0	1, 2, 3		0	1	2, 3				
3000	6.10	6.10	6.10	6.10	6.10	25.47	10.69	10.69	10.69	10.69	10.69	36.30	13.82	13.82	13.82	13.82	13.82	47.93			
3300	5.30	5.30	5.30	5.30	5.30	19.14	8.88	9.16	9.16	9.16	9.16	27.27	11.73	12.57	12.57	12.57	12.57	36.01			
3600	4.64	4.64	4.64	4.64	4.64	14.74	7.24	7.81	7.81	7.81	7.81	21.00	9.48	11.36	11.36	11.36	11.36	27.73			
3900	4.10	4.10	4.10	4.10	4.10	11.59	5.96	6.66	6.66	6.66	6.66	16.52	7.76	9.68	9.68	9.68	9.68	21.81			
4200	3.64	3.64	3.64	3.64	3.64	9.28	4.96	5.74	5.74	5.74	5.74	13.23	6.42	8.34	8.34	8.34	8.34	17.47			
4500	3.23	3.25	3.25	3.25	3.25	7.55	4.19	5.00	5.00	5.00	5.00	10.75	5.39	7.27	7.27	7.27	7.27	14.20			
4800	2.79	2.88	2.88	2.88	2.88	6.22	3.47	4.39	4.39	4.39	4.39	8.86	4.59	6.39	6.39	6.39	6.39	11.70			
5100	2.43	2.56	2.56	2.56	2.56	5.19	3.01	3.89	3.89	3.89	3.89	7.39	3.96	5.66	5.42	5.66	5.66	9.76			
5400	2.14	2.28	2.28	2.28	2.28	4.37	2.63	3.47	3.46	3.47	3.47	6.22	3.44	5.05	4.70	5.05	5.05	8.22			
5700	1.88	2.05	2.05	2.05	2.05	3.71	2.32	3.12	2.99	3.12	3.12	5.29	3.02	4.53	4.09	4.53	4.53	6.99			
6000	1.66	1.85	1.80	1.85	1.85	3.18	2.06	2.81	2.59	2.81	2.81	4.54	2.67	4.09	3.58	4.09	4.09	5.99			
Sections below exceed the normal delivery length of 12000mm																					
6300	1.48	1.67	1.57	1.67	1.67	2.75	1.84	2.55	2.23	2.55	2.55	3.92	2.38	3.71	3.12	3.71	3.71	5.18			
6600	1.32	1.53	1.35	1.53	1.53	2.39	1.65	2.32	1.86	2.32	2.32	3.41	2.13	3.38	2.72	3.38	3.38	4.50			
6900	1.19	1.40	1.17	1.40	1.40	2.09	1.49	2.13	1.63	2.13	2.13	2.98	1.91	3.09	2.35	3.09	3.09	3.94			
7200	1.07	1.28	1.02	1.28	1.28	1.84	1.35	1.95	1.43	1.95	1.95	2.63	1.72	2.84	2.05	2.83	2.84	3.47			
7500	0.97	1.18	0.89	1.18	1.18	1.63	1.23	1.80	1.26	1.80	1.80	2.32	1.55	2.62	1.80	2.56	2.62	3.08			
7800	0.89	1.09	0.79	1.09	1.09	1.45	1.12	1.66	1.12	1.66	1.66	2.08	1.41	2.42	1.59	2.32	2.42	2.76			
8100	0.81	1.01	0.69	1.01	1.01	1.30	1.02	1.54	1.00	1.54	1.54	1.86	1.29	2.24	1.42	2.11	2.24	2.48			
8400	0.74	0.94	0.62	0.94	0.94	1.18	0.94	1.44	0.90	1.40	1.44	1.68	1.18	2.09	1.25	1.92	2.09	2.24			
8700	0.68	0.88	0.55	0.87	0.88	1.07	0.87	1.34	0.81	1.27	1.34	1.52	1.08	1.95	1.11	1.75	1.95	2.03			
9000	0.62	0.82	0.47	0.79	0.82	0.98	0.80	1.25	0.72	1.15	1.25	1.37	0.99	1.80	0.99	1.60	1.82	1.84			

Bridging > Span mm	Z/C 25019 (kN/m)						Z/C 25024 (kN/m)							
	INWARD			OUTWARD			L/150	INWARD			OUTWARD			L/150
	0	1, 2, 3	0	1	2, 3	0		1, 2, 3	0	1	2, 3			
4500	5.27	5.83	5.83	5.83	5.83	17.47	6.82	9.22	9.22	9.22	9.22	24.09		
4800	4.51	5.26	5.26	5.26	5.26	14.39	5.80	8.91	8.19	8.19	8.19	19.85		
5100	3.90	4.77	4.77	4.77	4.77	12.00	4.99	7.25	7.25	7.25	7.25	16.55		
5400	3.41	4.35	4.35	4.35	4.35	10.11	4.34	6.47	6.27	6.47	6.47	13.94		
5700	3.00	3.96	3.96	3.96	3.96	8.59	3.81	5.81	5.45	5.81	5.81	11.85		
6000	2.66	3.57	3.44	3.57	3.57	7.37	3.36	5.24	4.74	5.24	5.24	10.16		
Sections below exceed the normal delivery length of 12000mm														
6300	2.37	3.24	2.94	3.24	3.24	6.37	2.97	4.75	4.10	4.75	4.75	8.78		
6600	2.12	2.95	2.46	2.95	2.95	5.54	2.65	4.33	3.53	4.33	4.33	7.64		
6900	1.91	2.70	2.15	2.70	2.70	4.85	2.37	3.96	3.05	3.96	3.96	6.68		
7200	1.73	2.48	1.88	2.48	2.48	4.26	2.13	3.64	2.65	3.64	3.64	5.88		
7500	1.57	2.28	1.66	2.28	2.28	3.77	1.93	3.35	2.32	3.35	3.35	5.20		
7800	1.43	2.11	1.47	2.11	2.11	3.35	1.75	3.10	2.05	3.10	3.10	4.63		
8100	1.31	1.96	1.31	1.96	1.96	3.00	1.59	2.88	1.81	2.82	2.88	4.13		
8400	1.20	1.82	1.17	1.82	1.82	2.69	1.46	2.67	1.59	2.56	2.67	3.70		
8700	1.11	1.70	1.04	1.69	1.70	2.42	1.34	2.49	1.41	2.33	2.49	3.33		
9000	1.02	1.59	0.93	1.53	1.59	2.18	1.23	2.33	1.25	2.13	2.33	3.01		

Bold capacities require grade 8.8 purlin bolts.

Values above dotted horizontal line in body of table are governed by the strength of the grade 8.8 bolt.

INWARD = Inward load capacity. OUTWARD = Outward load capacity. L/150 = Load for deflection span/150.

See also: Design notes for capacity tables.

Double Continuous Spans

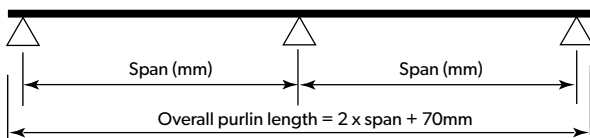

DOUBLE CONTINUOUS SPANS

Bridging > Span mm	Z/C 30024 (kN/m)					Z/C 30030 (kN/m)				
	INWARD		OUTWARD		L/150	INWARD		OUTWARD		L/150
	0	1, 2, 3	0	1, 2, 3		0	1, 2, 3	0	1, 2, 3	
6000	4.86	6.83	6.83	6.83	16.87	5.91	10.26	10.26	10.26	22.50

Sections below exceed the normal delivery length of 12000mm

6300	4.31	6.31	6.31	6.31	14.57	5.17	9.31	9.26	9.31	19.44
6600	3.83	5.84	5.84	5.84	12.67	4.56	8.48	8.24	8.48	16.91
6900	3.42	5.41	5.41	5.41	11.09	4.05	7.76	7.37	7.76	14.79
7200	3.08	5.00	4.84	5.00	9.76	3.62	7.13	6.61	7.13	13.02
7500	2.78	4.61	4.32	4.61	8.64	3.25	6.57	5.95	6.57	11.52
7800	2.53	4.26	3.82	4.26	7.68	2.93	6.07	5.34	6.07	10.24
8100	2.30	3.95	3.38	3.95	6.85	2.66	5.63	4.76	5.63	9.15
8400	2.10	3.67	3.01	3.67	6.15	2.42	5.24	4.25	5.24	8.20
8700	1.92	3.42	2.65	3.42	5.53	2.21	4.88	3.80	4.88	7.38
9000	1.76	3.20	2.40	3.20	5.00	2.03	4.56	3.39	4.56	6.67
9300	1.62	3.00	2.17	3.00	4.53	1.87	4.27	3.03	4.27	6.04
9600	1.50	2.81	1.98	2.81	4.12	1.72	4.01	2.71	4.01	5.49

Bridging > Span mm	Z/C 35030 (kN/m)				L/150
	INWARD		OUTWARD		
	0	1, 2, 3	0	1, 2, 3	
6000	8.28	11.79	11.79	11.79	34.93

Sections below exceed the normal delivery length of 12000mm

6300	7.28	10.89	10.89	10.89	30.17
6600	6.45	10.09	10.09	10.09	26.24
6900	5.74	9.37	9.37	9.37	22.97
7200	5.15	8.72	8.72	8.72	20.21
7500	4.63	8.04	8.04	8.04	17.88
7800	4.16	7.43	7.43	7.43	15.90
8100	3.76	6.89	6.89	6.89	14.20
8400	3.41	6.41	6.41	6.41	12.73
8700	3.11	5.97	5.93	5.97	11.46
9000	2.84	5.58	5.40	5.58	10.35
9300	2.61	5.23	4.93	5.23	9.38
9600	2.41	4.91	4.48	4.91	8.53

Bold capacities require grade 8.8 purlin bolts.

Values above dotted horizontal line in body of table are governed by the strength of the grade 8.8 bolt.

INWARD = Inward load capacity. OUTWARD = Outward load capacity. L/150 = Load for deflection span/150.

See also: Design notes for capacity tables.

Double Continuous Spans

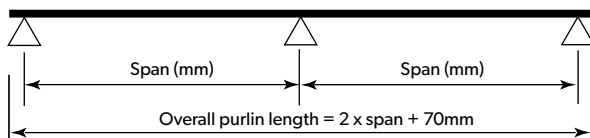

Bridging > Span mm	Z 10010 (kN/m)						L/150	Z 10012 (kN/m)						L/150
	INWARD			OUTWARD				INWARD			OUTWARD			
	0	1, 2, 3	0	1	2, 3	0		1, 2, 3	0	1	2	3		
2100	6.75	6.75	6.75	6.75	6.75	6.75	9.90	8.30	8.30	8.30	8.30	8.30	8.30	12.20
2400	5.13	5.13	5.13	5.13	5.13	5.13	6.53	6.44	6.44	6.44	6.44	6.44	6.44	8.05
2700	3.80	3.90	3.90	3.90	3.90	3.90	4.52	4.31	4.75	4.75	4.75	4.75	4.75	5.57
3000	2.90	2.98	2.98	2.98	2.98	2.98	3.26	3.30	3.62	3.61	3.62	3.62	3.62	4.01
3300	2.28	2.35	2.29	2.35	2.35	2.35	2.42	2.59	2.86	2.71	2.86	2.86	2.86	2.98
3600	1.84	1.90	1.72	1.90	1.90	1.90	1.85	2.09	2.32	2.08	2.32	2.32	2.32	2.27
3900	1.51	1.57	1.31	1.57	1.57	1.57	1.44	1.72	1.91	1.59	1.91	1.91	1.91	1.77
4200	1.25	1.32	1.02	1.32	1.32	1.32	1.15	1.43	1.61	1.19	1.61	1.61	1.61	1.41
4500	1.05	1.13	0.80	1.13	1.13	1.13	0.94	1.20	1.37	0.95	1.37	1.37	1.37	1.15
4800	0.89	0.97	0.65	0.97	0.97	0.97	0.78	1.02	1.18	0.78	1.18	1.18	1.18	0.95
5100	0.76	0.85	0.53	0.85	0.85	0.85	0.65	0.88	1.03	0.64	1.00	1.03	1.03	0.79
5400	0.66	0.75	0.43	0.71	0.75	0.75	0.55	0.76	0.91	0.53	0.85	0.91	0.91	0.67
5700	0.57	0.66		0.59	0.66	0.66	0.47	0.66	0.80	0.45	0.72	0.80	0.80	0.57
6000	0.50	0.59		0.50	0.59	0.59	0.40	0.58	0.72		0.61	0.72	0.72	0.49
6300	0.45	0.59		0.45	0.59	0.59	0.36	0.51	0.72		0.53	0.72	0.72	0.44
6600	0.40	0.53			0.53	0.53	0.31	0.45	0.64		0.45	0.62	0.64	0.38
6900		0.48			0.46	0.46	0.27	0.40	0.58			0.55	0.58	0.34

Bridging > Span mm	Z 10015 (kN/m)							L/150	Z 10019 (kN/m)							L/150	
	INWARD			OUTWARD					INWARD			OUTWARD					
	0	1	2, 3	0	1	2	3		0	1	2, 3	0	1	2	3		
2100	10.82	10.82	10.82	10.82	10.82	10.82	10.82	15.97	15.08	15.08	15.08	15.08	15.08	15.08	15.08	15.08	21.19
2400	8.39	8.39	8.39	8.39	8.39	8.39	8.39	10.53	11.70	11.70	11.70	11.70	11.70	11.70	11.70	11.70	13.97
2700	5.18	6.19	6.19	6.02	6.19	6.19	6.19	7.29	6.57	8.63	8.63	8.49	8.63	8.63	8.63	8.63	9.67
3000	3.96	4.72	4.72	4.43	4.72	4.72	4.72	5.25	5.02	6.59	6.59	6.24	6.59	6.59	6.59	6.59	6.96
3300	3.12	3.73	3.73	3.37	3.73	3.73	3.73	3.90	3.96	5.20	5.20	4.70	5.20	5.20	5.20	5.20	5.18
3600	2.52	3.02	3.02	2.62	3.02	3.02	3.02	2.98	3.19	4.21	4.21	3.63	4.21	4.21	4.21	4.21	3.95
3900	2.07	2.49	2.49	2.08	2.49	2.49	2.49	2.32	2.62	3.48	3.48	2.86	3.48	3.48	3.48	3.48	3.08
4200	1.73	2.10	2.10	1.66	2.10	2.10	2.10	1.84	2.19	2.92	2.92	2.27	2.92	2.92	2.92	2.92	2.45
4500	1.46	1.79	1.79	1.34	1.75	1.79	1.79	1.49	1.85	2.49	2.49	1.82	2.48	2.49	2.49	2.49	1.98
4800	1.25	1.54	1.54	1.09	1.47	1.54	1.54	1.23	1.58	2.15	2.15	1.48	2.09	2.15	2.15	2.15	1.63
5100	1.08	1.34	1.34	0.89	1.25	1.34	1.34	1.03	1.36	1.87	1.87	1.22	1.77	1.87	1.87	1.87	1.36
5400	0.94	1.18	1.18	0.73	1.07	1.18	1.18	0.88	1.19	1.65	1.65	1.01	1.50	1.65	1.65	1.65	1.14
5700	0.82	1.05	1.05	0.61	0.92	1.05	1.05	0.75	1.04	1.46	1.46	0.84	1.29	1.46	1.46	1.46	0.97
6000	0.72	0.94	0.94	0.52	0.80	0.93	0.94	0.65	0.92	1.30	1.30	0.71	1.11	1.30	1.30	1.30	0.83
6300	0.67	0.90	0.93	0.47	0.74	0.88	0.93	0.58	0.84	1.26	1.30	0.63	1.03	1.26	1.30	1.30	0.74
6600	0.59	0.80	0.84	0.40	0.64	0.78	0.84	0.50	0.75	1.12	1.17	0.54	0.88	1.11	1.17	1.17	0.64
6900	0.53	0.72	0.76		0.55	0.69	0.76	0.44	0.67	1.00	1.05	0.47	0.76	0.97	1.05	1.05	0.56
7200	0.47	0.65	0.69		0.48	0.61	0.68	0.39	0.60	0.90	0.96	0.41	0.66	0.86	0.96	0.96	0.50
7500	0.42	0.58	0.63		0.42	0.54	0.61	0.34	0.54	0.81	0.87		0.58	0.76	0.87	0.87	0.44
7800		0.53	0.57			0.49	0.55	0.30	0.49	0.73	0.80		0.51	0.68	0.78	0.78	0.39

Bold capacities require grade 8.8 purlin bolts.

Values above dotted horizontal line in body of table are governed by the strength of the grade 8.8 bolt.

INWARD = Inward load capacity. OUTWARD = Outward load capacity. L/150 = Load for deflection span/150.

See also: Design notes for capacity tables.

Double Lapped Spans

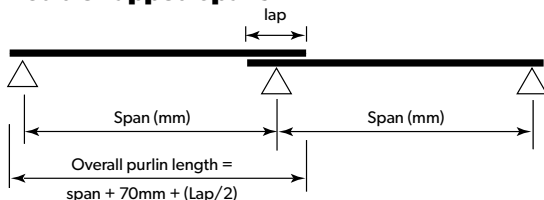

DOUBLE LAPPED SPANS

Bridging > Span mm	Z 15012 (kN/m)							Z 15015 (kN/m)								
	INWARD			OUTWARD				L/150	INWARD			OUTWARD				L/150
	0	1, 2, 3		0	1	2	3		0	1	2, 3	0	1	2	3	
2400	8.87	8.87		8.87	8.87	8.87	8.87	23.35	14.23	14.23	14.23	14.23	14.23	14.23	14.23	31.72
2700	7.20	7.20		7.20	7.20	7.20	7.20	16.21	11.37	11.37	11.37	11.37	11.37	11.37	11.37	22.02
3000	5.94	5.94		5.94	5.94	5.94	5.94	11.68	9.30	9.30	9.30	9.30	9.30	9.30	9.30	15.86
3300	4.98	4.98		4.98	4.98	4.98	4.98	8.68	7.76	7.76	7.76	7.76	7.76	7.76	7.76	11.79
3600	4.22	4.22		4.22	4.22	4.22	4.22	6.61	6.53	6.53	6.53	6.53	6.53	6.53	6.53	8.99
3900	3.26	3.61		3.61	3.61	3.61	3.61	5.15	3.79	5.36	5.36	5.17	5.36	5.36	5.36	7.00
4200	2.69	3.12		3.12	3.12	3.12	3.12	4.09	3.13	4.42	4.42	4.10	4.42	4.42	4.42	5.55
4500	2.26	2.72		2.55	2.72	2.72	2.72	3.30	2.63	3.70	3.70	3.28	3.70	3.70	3.70	4.48
4800	1.92	2.39		2.04	2.39	2.39	2.39	2.70	2.23	3.15	3.15	2.63	3.15	3.15	3.15	3.66
5100	1.65	2.07		1.65	2.07	2.07	2.07	2.23	1.92	2.72	2.72	2.08	2.72	2.72	2.72	3.03
5400	1.43	1.80		1.36	1.80	1.80	1.80	1.87	1.67	2.37	2.37	1.73	2.37	2.37	2.37	2.54
5700	1.24	1.58		1.13	1.58	1.58	1.58	1.58	1.46	2.08	2.08	1.45	2.08	2.08	2.08	2.15
6000	1.09	1.40		0.94	1.40	1.40	1.40	1.35	1.28	1.84	1.84	1.23	1.84	1.84	1.84	1.83
6300	0.97	1.25		0.80	1.25	1.25	1.25	1.16	1.14	1.64	1.64	1.05	1.63	1.64	1.64	1.57
6600	0.86	1.12		0.68	1.11	1.12	1.12	1.00	1.02	1.48	1.48	0.91	1.42	1.48	1.48	1.36
6900	0.77	1.01		0.58	0.98	1.01	1.01	0.89	0.91	1.33	1.33	0.79	1.25	1.33	1.33	1.19
7200	0.69	0.92		0.49	0.85	0.92	0.92	0.79	0.82	1.21	1.21	0.68	1.10	1.21	1.21	1.05
7500	0.62	0.84		0.43	0.74	0.84	0.84	0.71	0.74	1.10	1.10	0.59	0.96	1.10	1.10	0.93
7800	0.56	0.77			0.64	0.77	0.77	0.63	0.67	1.01	1.01	0.52	0.84	1.01	1.01	0.83
8100	0.51	0.71			0.57	0.71	0.71	0.57	0.61	0.93	0.93	0.45	0.72	0.93	0.93	0.74
8400	0.46	0.65			0.50	0.65	0.65	0.52	0.56	0.85	0.85	0.40	0.64	0.85	0.85	0.66
8700	0.42	0.60			0.44	0.60	0.60	0.47	0.51	0.79	0.79		0.57	0.78	0.79	0.60
9000	0.38	0.56				0.55	0.56	0.42	0.47	0.73	0.73		0.51	0.71	0.73	0.54
9300	0.36	0.56				0.52	0.56	0.39	0.45	0.71	0.73		0.48	0.67	0.73	0.50
9600	0.33	0.52				0.47	0.52	0.36	0.41	0.65	0.68		0.44	0.61	0.68	0.46
9900	0.30	0.48				0.42	0.48	0.32		0.60	0.63			0.55	0.63	0.42

Bold capacities require grade 8.8 purlin bolts.

Values above dotted horizontal line in body of table are governed by the strength of the grade 8.8 bolt.

INWARD = Inward load capacity. OUTWARD = Outward load capacity. L/150 = Load for deflection span/150.

See also: Design notes for capacity tables.

Double Lapped Spans

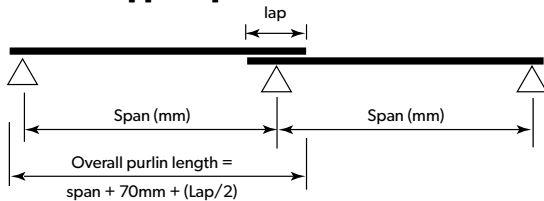

Bridging > Span mm	Z 15019 (kN/m)								L/150	Z 15024 (kN/m)								L/150
	INWARD			OUTWARD				L/150		INWARD			OUTWARD				L/150	
	0	1	2, 3	0	1	2	3			0	1	2, 3	0	1	2	3		
2400	20.06	20.06	20.06	20.06	20.06	20.06	20.06	41.39	21.18	21.18	21.18	21.18	21.18	21.18	21.18	55.20		
2700	15.80	16.03	16.03	16.03	16.03	16.03	16.03	28.73	18.88	18.88	18.88	18.88	18.88	18.88	18.88	38.31		
3000	12.63	13.12	13.12	13.12	13.12	13.12	13.12	20.70	17.03	17.03	17.03	17.03	17.03	17.03	17.03	27.61		
3300	10.31	10.94	10.94	10.94	10.94	10.94	10.94	15.38	13.92	15.42	15.42	15.42	15.42	15.42	15.42	20.51		
3600	8.58	9.27	9.27	9.27	9.27	9.27	9.27	11.72	11.49	13.06	13.06	13.06	13.06	13.06	13.06	15.64		
3900	4.75	7.55	7.55	6.84	7.55	7.55	7.55	9.13	5.66	10.64	10.64	9.48	10.64	10.64	10.64	12.18		
4200	3.93	6.22	6.22	5.46	6.22	6.22	6.22	7.25	4.67	8.77	8.77	7.53	8.77	8.77	8.77	9.66		
4500	3.30	5.22	5.22	4.42	5.22	5.22	5.22	5.84	3.92	7.36	7.36	6.08	7.36	7.36	7.36	7.79		
4800	2.80	4.44	4.44	3.59	4.44	4.44	4.44	4.78	3.33	6.26	6.26	4.93	6.26	6.26	6.26	6.37		
5100	2.41	3.83	3.83	2.95	3.83	3.83	3.83	3.96	2.86	5.40	5.40	3.99	5.40	5.40	5.40	5.28		
5400	2.09	3.34	3.34	2.42	3.32	3.34	3.34	3.31	2.48	4.69	4.70	3.27	4.70	4.70	4.70	4.42		
5700	1.83	2.93	2.93	2.01	2.85	2.93	2.93	2.80	2.17	4.08	4.13	2.71	4.05	4.13	4.13	3.73		
6000	1.61	2.58	2.60	1.69	2.47	2.60	2.60	2.39	1.92	3.57	3.66	2.27	3.49	3.66	3.66	3.18		
6300	1.43	2.29	2.32	1.44	2.16	2.32	2.32	2.05	1.70	3.16	3.26	1.91	3.04	3.26	3.26	2.74		
6600	1.28	2.04	2.08	1.23	1.89	2.08	2.08	1.78	1.52	2.81	2.93	1.63	2.65	2.93	2.93	2.37		
6900	1.14	1.83	1.88	1.05	1.67	1.88	1.88	1.56	1.36	2.51	2.65	1.40	2.33	2.65	2.65	2.07		
7200	1.03	1.64	1.70	0.91	1.48	1.70	1.70	1.38	1.23	2.26	2.40	1.21	2.06	2.40	2.40	1.82		
7500	0.93	1.49	1.55	0.79	1.31	1.55	1.55	1.22	1.11	2.04	2.19	1.05	1.83	2.19	2.19	1.61		
7800	0.85	1.35	1.42	0.69	1.16	1.39	1.42	1.09	1.01	1.85	2.00	0.92	1.62	1.98	2.00	1.43		
8100	0.77	1.23	1.31	0.60	1.03	1.26	1.31	0.98	0.92	1.68	1.84	0.81	1.44	1.79	1.84	1.28		
8400	0.70	1.13	1.20	0.53	0.92	1.14	1.20	0.88	0.84	1.54	1.70	0.72	1.27	1.61	1.70	1.15		
8700	0.64	1.03	1.11	0.47	0.81	1.04	1.11	0.80	0.77	1.41	1.57	0.64	1.12	1.46	1.57	1.04		
9000	0.59	0.95	1.03	0.42	0.72	0.94	1.03	0.72	0.71	1.29	1.46	0.57	1.00	1.33	1.46	0.94		
9300	0.55	0.92	1.03		0.67	0.91	1.02	0.67	0.66	1.24	1.45	0.53	0.91	1.27	1.45	0.87		
9600	0.51	0.85	0.96		0.60	0.83	0.94	0.61	0.61	1.14	1.35	0.48	0.82	1.16	1.34	0.79		
9900	0.47	0.78	0.89		0.54	0.76	0.86	0.56	0.57	1.06	1.26	0.43	0.73	1.06	1.23	0.72		
10200	0.43	0.73	0.83		0.49	0.69	0.80	0.51	0.53	0.98	1.17		0.66	0.97	1.13	0.65		
10500	0.40	0.67	0.77		0.44	0.63	0.73	0.46	0.49	0.91	1.08		0.60	0.88	1.04	0.60		

Bold capacities require grade 8.8 purlin bolts.

Values above dotted horizontal line in body of table are governed by the strength of the grade 8.8 bolt.

INWARD = Inward load capacity. OUTWARD = Outward load capacity. L/150 = Load for deflection span/150.

See also: Design notes for capacity tables.

Double Lapped Spans

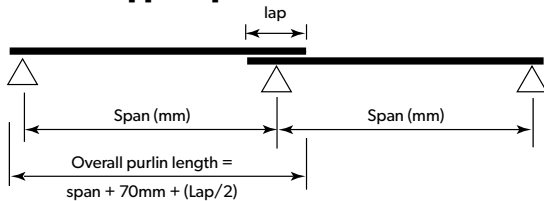

DOUBLE LAPPED SPANS

Bridging > Span mm	Z 20015 (kN/m)						L/150
	INWARD			OUTWARD			
	0	1, 2, 3	0	1	2	3	
3000	9.07	9.07	9.07	9.07	9.07	9.07	31.37
3300	7.71	7.71	7.71	7.71	7.71	7.71	23.30
3600	6.63	6.63	6.63	6.63	6.63	6.63	17.76
3900	5.54	5.75	5.75	5.75	5.75	5.75	13.84
4200	4.56	5.02	5.02	5.02	5.02	5.02	10.98
4500	3.81	4.42	4.42	4.42	4.42	4.42	8.86
4800	3.23	3.92	3.92	3.92	3.92	3.92	7.24
5100	2.78	3.49	3.49	3.49	3.49	3.49	6.00
5400	2.41	3.13	3.10	3.13	3.13	3.13	5.02
5700	2.10	2.82	2.62	2.82	2.82	2.82	4.24
6000	1.85	2.50	2.20	2.50	2.50	2.50	3.62
6300	1.64	2.23	1.86	2.23	2.23	2.23	3.11
6600	1.46	2.00	1.59	2.00	2.00	2.00	2.69
6900	1.31	1.81	1.37	1.81	1.81	1.81	2.35
7200	1.18	1.64	1.18	1.64	1.64	1.64	2.06
7500	1.07	1.49	1.03	1.49	1.49	1.49	1.81
7800	0.97	1.37	0.90	1.37	1.37	1.37	1.61
8100	0.88	1.26	0.79	1.26	1.26	1.26	1.43
8400	0.81	1.16	0.67	1.15	1.16	1.16	1.28
8700	0.74	1.07	0.60	1.04	1.07	1.07	1.15
9000	0.68	0.99	0.54	0.94	0.99	0.99	1.03
9300	0.64	0.99	0.50	0.87	0.99	0.99	0.96
9600	0.59	0.92	0.45	0.78	0.92	0.92	0.87
9900	0.54	0.86	0.41	0.70	0.86	0.86	0.80
10200	0.50	0.80		0.63	0.80	0.80	0.73
10500	0.47	0.75		0.57	0.75	0.75	0.68
10800	0.43	0.71		0.52	0.71	0.71	0.63
11100		0.66		0.47	0.66	0.66	0.58
11400		0.63		0.43	0.61	0.63	0.54
Sections below exceed the normal delivery length of 12000mm							
11700		0.59			0.56	0.59	0.50
12000		0.56			0.52	0.56	0.47

Bold capacities require grade 8.8 purlin bolts.
 Values above dotted horizontal line in body of table are governed by the strength of the grade 8.8 bolt.
 INWARD = Inward load capacity. OUTWARD = Outward load capacity. L/150 = Load for deflection span/150.
 See also: Design notes for capacity tables.

Double Lapped Spans

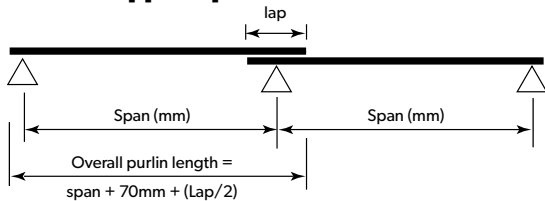

Bridging > Span mm	Z 20019 (kN/m)							L/150	Z 20024 (kN/m)							L/150		
	INWARD			OUTWARD					L/150	INWARD			OUTWARD				L/150	
	0	1	2, 3	0	1	2	3			0	1	2, 3	0	1	2			3
3000	17.00	17.00	17.00	17.00	17.00	17.00	17.00	44.69	17.03	17.03	17.03	17.03	17.03	17.03	17.03	59.02		
3300	14.16	14.16	14.16	14.16	14.16	14.16	14.16	33.21	15.51	15.51	15.51	15.51	15.51	15.51	15.51	43.85		
3600	11.94	11.94	11.94	11.94	11.94	11.94	11.94	25.31	14.25	14.25	14.25	14.25	14.25	14.25	14.25	33.42		
3900	7.09	10.18	10.18	10.18	10.18	10.18	10.18	19.72	8.88	13.18	13.18	13.18	13.18	13.18	13.18	26.04		
4200	5.82	8.77	8.77	8.77	8.77	8.77	8.77	15.65	7.24	12.25	12.25	12.25	12.25	12.25	12.25	20.66		
4500	4.86	7.61	7.61	7.61	7.61	7.61	7.61	12.62	6.01	11.12	11.12	11.12	11.12	11.12	11.12	16.66		
4800	4.12	6.51	6.51	6.39	6.51	6.51	6.51	10.32	5.06	9.46	9.46	8.70	9.46	9.46	9.46	13.63		
5100	3.53	5.61	5.61	5.31	5.61	5.61	5.61	8.54	4.32	8.15	8.15	7.28	8.15	8.15	8.15	11.28		
5400	3.06	4.88	4.88	4.45	4.88	4.88	4.88	7.15	3.73	7.10	7.10	6.16	7.10	7.10	7.10	9.44		
5700	2.67	4.29	4.29	3.70	4.29	4.29	4.29	6.05	3.25	6.24	6.24	5.19	6.24	6.24	6.24	7.98		
6000	2.36	3.80	3.80	3.02	3.80	3.80	3.80	5.16	2.85	5.53	5.53	4.38	5.53	5.53	5.53	6.81		
6300	2.09	3.39	3.39	2.58	3.39	3.39	3.39	4.43	2.52	4.90	4.93	3.71	4.93	4.93	4.93	5.85		
6600	1.87	3.05	3.05	2.22	3.05	3.05	3.05	3.84	2.25	4.36	4.43	3.17	4.43	4.43	4.43	5.06		
6900	1.67	2.75	2.75	1.93	2.75	2.75	2.75	3.34	2.01	3.90	4.00	2.73	3.96	4.00	4.00	4.41		
7200	1.51	2.50	2.50	1.68	2.50	2.50	2.50	2.93	1.81	3.51	3.63	2.37	3.53	3.63	3.63	3.87		
7500	1.37	2.28	2.28	1.48	2.28	2.28	2.28	2.58	1.64	3.17	3.31	2.07	3.15	3.31	3.31	3.41		
7800	1.24	2.08	2.08	1.30	2.07	2.08	2.08	2.29	1.49	2.88	3.03	1.50	2.83	3.03	3.03	3.02		
8100	1.13	1.91	1.91	1.16	1.86	1.91	1.91	2.04	1.35	2.63	2.78	1.57	2.55	2.78	2.78	2.69		
8400	1.04	1.76	1.76	1.02	1.67	1.76	1.76	1.82	1.24	2.40	2.57	1.39	2.31	2.57	2.57	2.40		
8700	0.95	1.63	1.63	0.90	1.50	1.63	1.63	1.63	1.14	2.21	2.37	1.22	2.09	2.37	2.37	2.16		
9000	0.87	1.51	1.51	0.80	1.35	1.51	1.51	1.48	1.05	2.03	2.20	1.09	1.90	2.20	2.20	1.96		
9300	0.82	1.48	1.51	0.74	1.21	1.51	1.51	1.37	0.97	1.96	2.19	1.00	1.79	2.17	2.19	1.82		
9600	0.75	1.37	1.40	0.67	1.09	1.40	1.40	1.25	0.90	1.81	2.04	0.89	1.60	1.99	2.04	1.66		
9900	0.70	1.26	1.31	0.60	0.99	1.31	1.31	1.14	0.83	1.68	1.90	0.80	1.44	1.83	1.90	1.52		
10200	0.65	1.17	1.22	0.54	0.90	1.22	1.22	1.04	0.78	1.56	1.78	0.72	1.30	1.68	1.78	1.39		
10500	0.60	1.09	1.15	0.49	0.82	1.13	1.15	0.96	0.72	1.45	1.67	0.65	1.18	1.56	1.67	1.28		
10800	0.56	1.01	1.08	0.44	0.75	1.04	1.08	0.88	0.67	1.35	1.57	0.59	1.07	1.44	1.57	1.18		
11100	0.52	0.94	1.01	0.40	0.68	0.96	1.01	0.81	0.63	1.26	1.47	0.54	0.98	1.33	1.47	1.09		
11400	0.49	0.88	0.95		0.63	0.89	0.95	0.75	0.59	1.17	1.39	0.49	0.89	1.24	1.39	1.01		
Sections below exceed the normal delivery length of 12000mm																		
11700	0.46	0.82	0.90		0.58	0.82	0.90	0.69	0.55	1.09	1.31	0.45	0.82	1.15	1.30	0.94		
12000	0.43	0.77	0.85		0.53	0.75	0.85	0.64	0.52	1.02	1.23	0.41	0.75	1.07	1.21	0.87		

Bold capacities require grade 8.8 purlin bolts.
 Values above dotted horizontal line in body of table are governed by the strength of the grade 8.8 bolt.
 INWARD = Inward load capacity. OUTWARD = Outward load capacity. L/150 = Load for deflection span/150.
 See also: Design notes for capacity tables.

Double Lapped Spans

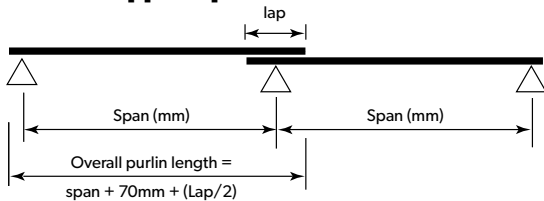

Bridging > Span mm	Z 25019 (kN/m)								L/150	Z 25024 (kN/m)								L/150
	INWARD				OUTWARD					INWARD				OUTWARD				
	0	1	2, 3		0	1	2	3		0	1	2, 3		0	1	2	3	
3000	15.13	15.13	15.13		15.13	15.13	15.13	15.13	72.59	17.03	17.03	17.03		17.03	17.03	17.03	17.03	100.20
3300	13.00	13.00	13.00		13.00	13.00	13.00	13.00	53.93	15.51	15.51	15.51		15.51	15.51	15.51	15.51	74.38
3600	11.28	11.28	11.28		11.28	11.28	11.28	11.28	41.11	14.25	14.25	14.25		14.25	14.25	14.25	14.25	56.70
3900	9.11	9.88	9.88		9.88	9.88	9.88	9.88	32.02	11.10	13.18	13.18		13.18	13.18	13.18	13.18	44.17
4200	7.47	8.72	8.72		8.72	8.72	8.72	8.72	25.41	9.04	12.25	12.25		12.25	12.25	12.25	12.25	35.05
4500	6.23	7.74	7.74		7.74	7.74	7.74	7.74	20.49	7.49	11.45	11.45		11.45	11.45	11.45	11.45	28.26
4800	5.27	6.91	6.91		6.91	6.91	6.91	6.91	16.76	6.30	10.75	10.75		10.75	10.75	10.75	10.75	23.11
5100	4.51	6.20	6.20		6.20	6.20	6.20	6.20	13.88	5.37	10.13	10.13		9.70	10.13	10.13	10.13	19.14
5400	3.91	5.59	5.59		5.59	5.59	5.59	5.59	11.61	4.63	9.06	9.06		8.12	9.06	9.06	9.06	16.02
5700	3.41	5.07	5.07		4.90	5.07	5.07	5.07	9.82	4.03	8.00	8.00		6.82	8.00	8.00	8.00	13.54
6000	3.00	4.61	4.61		4.00	4.61	4.61	4.61	8.37	3.53	7.09	7.09		5.71	7.09	7.09	7.09	11.55
6300	2.66	4.20	4.20		3.41	4.20	4.20	4.20	7.20	3.12	6.32	6.32		4.82	6.32	6.32	6.32	9.93
6600	2.37	3.85	3.85		2.93	3.85	3.85	3.85	6.23	2.78	5.68	5.68		4.11	5.68	5.68	5.68	8.59
6900	2.12	3.49	3.49		2.53	3.49	3.49	3.49	5.43	2.49	5.13	5.13		3.53	5.13	5.13	5.13	7.49
7200	1.91	3.17	3.17		2.20	3.17	3.17	3.17	4.76	2.24	4.65	4.65		3.06	4.65	4.65	4.65	6.56
7500	1.72	2.89	2.89		1.93	2.89	2.89	2.89	4.19	2.02	4.22	4.24		2.65	4.22	4.24	4.24	5.78
7800	1.56	2.64	2.64		1.70	2.64	2.64	2.64	3.72	1.83	3.82	3.88		2.30	3.78	3.88	3.88	5.12
8100	1.42	2.43	2.43		1.50	2.43	2.43	2.43	3.31	1.67	3.48	3.57		2.01	3.40	3.57	3.57	4.56
8400	1.30	2.24	2.24		1.31	2.23	2.24	2.24	2.96	1.53	3.18	3.29		1.76	3.07	3.29	3.29	4.08
8700	1.19	2.07	2.07		1.16	2.00	2.07	2.07	2.65	1.40	2.92	3.04		1.56	2.77	3.04	3.04	3.66
9000	1.10	1.92	1.92		1.03	1.78	1.92	1.92	2.39	1.29	2.68	2.82		1.38	2.49	2.82	2.82	3.30
9300	1.02	1.92	1.92		0.95	1.60	1.92	1.92	2.22	1.20	2.58	2.81		1.26	2.33	2.81	2.81	3.05
9600	0.95	1.78	1.78		0.85	1.44	1.78	1.78	2.01	1.11	2.38	2.62		1.12	2.08	2.62	2.62	2.77
9900	0.88	1.66	1.66		0.76	1.30	1.66	1.66	1.83	1.02	2.19	2.44		1.01	1.87	2.44	2.44	2.52
10200	0.81	1.55	1.55		0.69	1.18	1.55	1.55	1.66	0.95	2.03	2.28		0.90	1.68	2.25	2.28	2.30
10500	0.76	1.44	1.46		0.62	1.07	1.46	1.46	1.52	0.88	1.88	2.14		0.81	1.52	2.08	2.14	2.10
10800	0.70	1.34	1.37		0.56	0.98	1.37	1.37	1.40	0.82	1.74	2.01		0.74	1.38	1.92	2.01	1.92
11100	0.66	1.24	1.29		0.50	0.89	1.29	1.29	1.28	0.77	1.62	1.89		0.67	1.26	1.77	1.89	1.78
11400	0.61	1.15	1.21		0.46	0.82	1.19	1.21	1.18	0.72	1.51	1.78		0.61	1.15	1.64	1.78	1.64
Sections below exceed the normal delivery length of 12000mm																		
11700	0.57	1.07	1.14		0.41	0.75	1.09	1.14	1.10	0.67	1.41	1.68		0.55	1.05	1.52	1.68	1.52
12000	0.54	1.00	1.08			0.69	1.00	1.08	1.03	0.63	1.31	1.59		0.51	0.95	1.40	1.59	1.42

Bold capacities require grade 8.8 purlin bolts.
 Values above dotted horizontal line in body of table are governed by the strength of the grade 8.8 bolt.
 INWARD = Inward load capacity. OUTWARD = Outward load capacity. L/150 = Load for deflection span/150.
 See also: Design notes for capacity tables.

Double Lapped Spans

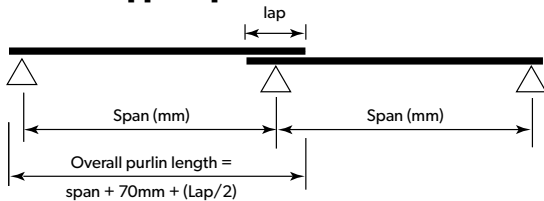

Bridging > Span mm	Z 30024 (kN/m)								L/150	Z 30030 (kN/m)								L/150
	INWARD			OUTWARD				L/150		INWARD				OUTWARD				
	0	1	2, 3	0-0	1	2	3			0	1	2	3	0	1	2	3	
6000	5.26	8.51	8.51	8.51	8.51	8.51	8.51	19.16	6.18	13.28	13.28	13.28	13.28	13.28	13.28	13.28	13.28	25.57
6300	4.61	7.80	7.80	7.80	7.80	7.80	7.80	16.47	5.40	12.05	12.05	12.05	12.05	11.73	12.05	12.05	12.05	21.97
6600	4.06	7.17	7.17	7.17	7.17	7.17	7.17	14.26	4.75	10.98	10.98	10.98	10.98	10.29	10.98	10.98	10.98	19.02
6900	3.61	6.61	6.61	6.59	6.61	6.61	6.61	12.42	4.21	10.04	10.04	10.04	10.04	9.08	10.04	10.04	10.04	16.58
7200	3.23	6.12	6.12	5.72	6.12	6.12	6.12	10.89	3.75	9.11	9.11	9.11	9.11	8.00	9.11	9.11	9.11	14.53
7500	2.90	5.67	5.67	4.99	5.67	5.67	5.67	9.60	3.37	8.30	8.30	8.30	8.30	7.01	8.30	8.30	8.30	12.81
7800	2.62	5.27	5.27	4.37	5.27	5.27	5.27	8.50	3.03	7.54	7.60	7.60	7.60	6.15	7.60	7.60	7.60	11.35
8100	2.38	4.90	4.90	3.80	4.90	4.90	4.90	7.57	2.75	6.86	6.98	6.98	6.98	5.44	6.98	6.98	6.98	10.10
8400	2.17	4.51	4.51	3.39	4.51	4.51	4.51	6.77	2.50	6.26	6.44	6.44	6.44	4.78	6.44	6.44	6.44	9.03
8700	1.98	4.18	4.18	3.04	4.18	4.18	4.18	6.07	2.29	5.74	5.95	5.95	5.95	4.22	5.95	5.95	5.95	8.10
9000	1.82	3.87	3.87	2.73	3.87	3.87	3.87	5.47	2.10	5.27	5.52	5.52	5.52	3.74	5.52	5.52	5.52	7.30
9300	1.69	3.86	3.86	2.58	3.86	3.86	3.86	5.07	1.94	5.10	5.51	5.51	5.51	3.43	5.45	5.51	5.51	6.76
9600	1.56	3.55	3.59	2.31	3.59	3.59	3.59	4.59	1.79	4.71	5.12	5.12	5.12	3.06	5.00	5.12	5.12	6.13
9900	1.44	3.28	3.35	2.08	3.35	3.35	3.35	4.18	1.66	4.35	4.78	4.78	4.78	2.73	4.59	4.78	4.78	5.57
10200	1.34	3.03	3.13	1.88	3.10	3.13	3.13	3.81	1.54	4.03	4.47	4.47	4.47	2.45	4.23	4.47	4.47	5.08
10500	1.24	2.81	2.93	1.70	2.85	2.93	2.93	3.48	1.43	3.75	4.18	4.18	4.18	2.21	3.91	4.18	4.18	4.65
10800	1.16	2.62	2.75	1.53	2.62	2.75	2.75	3.19	1.33	3.48	3.93	3.93	3.93	2.00	3.61	3.93	3.93	4.26
11100	1.08	2.44	2.59	1.39	2.41	2.59	2.59	2.93	1.25	3.23	3.69	3.69	3.69	1.81	3.35	3.69	3.69	3.91
11400	1.01	2.27	2.44	1.26	2.20	2.44	2.44	2.70	1.17	3.01	3.48	3.48	3.48	1.64	3.10	3.48	3.48	3.61
Sections below exceed the normal delivery length of 12000mm																		
11700	0.95	2.12	2.30	1.15	2.02	2.30	2.30	2.49	1.09	2.80	3.29	3.29	3.29	1.50	2.86	3.29	3.29	3.33
12000	0.89	1.98	2.18	1.05	1.85	2.18	2.18	2.31	1.03	2.62	3.11	3.11	3.11	1.37	2.63	3.11	3.11	3.08
12300	0.85	1.91	2.30	1.00	1.78	2.30	2.30	2.22	0.98	2.55	3.27	3.27	3.27	1.31	2.57	3.25	3.27	2.96
12600	0.80	1.79	2.17	0.91	1.64	2.17	2.17	2.06	0.92	2.38	3.10	3.10	3.10	1.20	2.36	3.04	3.10	2.75
12900	0.75	1.68	2.06	0.84	1.52	2.06	2.06	1.91	0.87	2.22	2.93	2.93	2.93	1.10	2.17	2.85	2.93	2.55
13200	0.71	1.57	1.95	0.77	1.41	1.95	1.95	1.78	0.82	2.08	2.78	2.78	2.78	1.01	1.99	2.67	2.78	2.38
13500	0.67	1.45	1.85	0.71	1.31	1.83	1.85	1.66	0.78	1.95	2.64	2.64	2.64	0.93	1.84	2.51	2.64	2.23
13800	0.64	1.37	1.76	0.65	1.22	1.72	1.76	1.56	0.74	1.83	2.51	2.51	2.51	0.86	1.69	2.36	2.51	2.09
14100	0.60	1.30	1.68	0.60	1.14	1.61	1.68	1.47	0.70	1.72	2.39	2.39	2.39	0.80	1.57	2.22	2.39	1.97
14400	0.57	1.22	1.60	0.56	1.07	1.51	1.60	1.39	0.66	1.62	2.27	2.28	2.28	0.74	1.45	2.09	2.28	1.85
14700	0.54	1.16	1.52	0.52	1.00	1.41	1.52	1.32	0.63	1.53	2.15	2.17	2.17	0.69	1.34	1.97	2.17	1.75
15000	0.52	1.10	1.46	0.48	0.93	1.32	1.46	1.25	0.60	1.45	2.05	2.08	2.08	0.64	1.25	1.86	2.08	1.65
15300	0.49	1.04	1.39	0.45	0.87	1.23	1.39	1.18	0.57	1.37	1.95	1.98	1.98	0.60	1.16	1.75	1.98	1.56
15600	0.47	0.99	1.33	0.42	0.81	1.16	1.33	1.12	0.55	1.29	1.85	1.90	1.90	0.56	1.08	1.65	1.89	1.48
15900	0.45	0.94	1.28		0.76	1.08	1.28	1.05	0.52	1.23	1.76	1.82	1.82	0.52	1.01	1.55	1.80	1.40
16200	0.43	0.90	1.22		0.71	1.02	1.22	1.00	0.50	1.16	1.68	1.75	1.75	0.49	0.94	1.45	1.71	1.33
16500	0.41	0.85	1.18		0.66	0.95	1.18	0.94	0.48	1.10	1.60	1.68	1.68	0.46	0.88	1.37	1.62	1.26
16800		0.81	1.13		0.62	0.88	1.13	0.90	0.46	1.05	1.53	1.61	1.61	0.43	0.82	1.29	1.55	1.20
17100		0.78	1.09		0.58	0.83	1.08	0.85	0.44	1.00	1.46	1.55	1.55	0.41	0.77	1.21	1.47	1.14
17400		0.74	1.04		0.54	0.79	1.02	0.81	0.42	0.95	1.40	1.49	1.49		0.72	1.14	1.40	1.08
17700		0.71	1.00		0.51	0.75	0.97	0.77	0.40	0.91	1.34	1.43	1.43		0.68	1.07	1.34	1.03

Bold capacities require grade 8.8 purlin bolts.
 Values above dotted horizontal line in body of table are governed by the strength of the grade 8.8 bolt.
 INWARD = Inward load capacity. OUTWARD = Outward load capacity. L/150 = Load for deflection span/150.
 See also: Design notes for capacity tables.

Double Lapped Spans

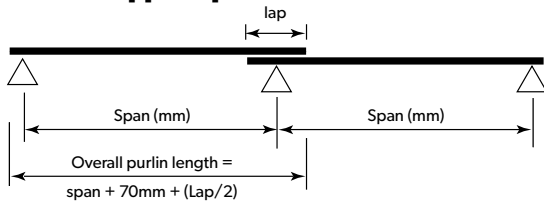

Bridging > Span mm	Z 35030 (kN/m)							L/150
	INWARD			OUTWARD				
	0	1	2, 3	0	1	2	3	
6000	9.33	14.61	14.61	14.61	14.61	14.61	14.61	39.69
6300	8.08	13.41	13.41	13.41	13.41	13.41	13.41	34.11
6600	7.05	12.35	12.35	12.35	12.35	12.35	12.35	29.53
6900	6.21	11.40	11.40	11.40	11.40	11.40	11.40	25.73
7200	5.51	10.56	10.56	10.56	10.56	10.56	10.56	22.56
7500	4.92	9.80	9.80	9.80	9.80	9.80	9.80	19.88
7800	4.41	9.11	9.11	9.11	9.11	9.11	9.11	17.61
8100	3.97	8.49	8.49	8.49	8.49	8.49	8.49	15.67
8400	3.59	7.88	7.88	7.64	7.88	7.88	7.88	14.01
8700	3.26	7.29	7.29	6.89	7.29	7.29	7.29	12.57
9000	2.97	6.76	6.76	6.19	6.76	6.76	6.76	11.33
9300	2.73	6.74	6.74	5.78	6.74	6.74	6.74	10.50
9600	2.51	6.27	6.27	5.19	6.27	6.27	6.27	9.52
9900	2.31	5.85	5.85	4.68	5.85	5.85	5.85	8.65
10200	2.13	5.47	5.47	4.23	5.47	5.47	5.47	7.89
10500	1.97	5.10	5.12	3.84	5.12	5.12	5.12	7.21
10800	1.83	4.74	4.81	3.49	4.81	4.81	4.81	6.61
11100	1.71	4.40	4.52	3.11	4.52	4.52	4.52	6.08
11400	1.59	4.10	4.26	2.86	4.26	4.26	4.26	5.60
Sections below exceed the normal delivery length of 12000mm								
11700	1.49	3.83	4.02	2.63	4.02	4.02	4.02	5.17
12000	1.39	3.58	4.01	2.43	4.01	4.01	4.01	4.78
12300	1.32	3.50	4.01	2.40	4.01	4.01	4.01	4.60
12600	1.24	3.26	3.79	2.23	3.74	3.74	3.74	4.26
12900	1.17	3.05	3.59	2.06	3.49	3.59	3.59	3.96
13200	1.10	2.85	3.40	1.90	3.26	3.40	3.40	3.69
13500	1.04	2.67	3.23	1.75	3.04	3.23	3.23	3.44
13800	0.99	2.51	3.07	1.62	2.83	3.07	3.07	3.22
14100	0.93	2.36	2.92	1.51	2.64	2.92	2.92	3.01
14400	0.89	2.22	2.79	1.40	2.46	2.79	2.79	2.82
14700	0.84	2.10	2.66	1.30	2.29	2.66	2.66	2.65
15000	0.80	1.98	2.54	1.22	2.14	2.54	2.54	2.49
15300	0.76	1.88	2.43	1.14	2.00	2.43	2.43	2.34
15600	0.73	1.78	2.33	1.06	1.87	2.33	2.33	2.20
15900	0.69	1.68	2.23	0.99	1.75	2.23	2.23	2.09
16200	0.66	1.60	2.14	0.92	1.65	2.14	2.14	1.99
16500	0.63	1.52	2.05	0.86	1.55	2.05	2.05	1.89
16800	0.60	1.44	1.97	0.81	1.45	1.97	1.97	1.80
17100	0.58	1.38	1.89	0.76	1.33	1.89	1.89	1.71
17400	0.55	1.28	1.82	0.71	1.26	1.81	1.82	1.63
17700	0.53	1.22	1.75	0.67	1.19	1.72	1.75	1.55

Bold capacities require grade 8.8 purlin bolts.
 Values above dotted horizontal line in body of table are governed by the strength of the grade 8.8 bolt.
 INWARD = Inward load capacity. OUTWARD = Outward load capacity. L/150 = Load for deflection span/150.
 See also: Design notes for capacity tables.

Double Lapped Spans

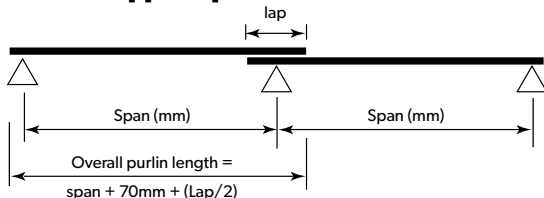

Bridging > Span mm	Z/C 10010 (kN/m)						Z/C 10012 (kN/m)								
	INWARD			OUTWARD			L/150	INWARD			OUTWARD			L/150	
	0	1, 2, 3		0	1	2, 3		0	1, 2, 3		0	1	2		3
2100	4.90	4.90		4.90	4.90	4.90	6.40	6.05	6.05		6.05	6.05	6.05	6.05	7.84
2400	3.80	3.80		3.80	3.80	3.80	4.36	4.63	4.63		4.63	4.63	4.63	4.63	5.32
2700	3.00	3.00		3.00	3.00	3.00	3.10	3.66	3.66		3.66	3.66	3.66	3.66	3.79
3000	2.43	2.43		2.37	2.43	2.43	2.29	2.90	2.96		2.80	2.96	2.96	2.96	2.80
3300	2.01	2.01		1.76	2.01	2.01	1.74	2.34	2.45		2.13	2.45	2.45	2.45	2.12
3600	1.68	1.69		1.33	1.69	1.69	1.36	1.92	2.06		1.61	2.06	2.06	2.06	1.66
3900	1.40	1.44		1.02	1.44	1.44	1.08	1.60	1.75		1.21	1.75	1.75	1.75	1.32
Sections below exceed the normal delivery length of 12000mm															
4200	1.17	1.24		0.80	1.24	1.24	0.87	1.34	1.51		0.96	1.50	1.51	1.51	1.07
4500	0.97	1.08		0.64	1.05	1.08	0.71	1.13	1.32		0.78	1.25	1.32	1.32	0.88
4800	0.82	0.95		0.50	0.86	0.95	0.59	0.96	1.16		0.64	1.04	1.16	1.16	0.73
5100	0.70	0.84		0.41	0.70	0.84	0.50	0.82	1.03		0.53	0.86	1.03	1.03	0.62
5400	0.60	0.75			0.58	0.75	0.42	0.67	0.91		0.44	0.68	0.91	0.91	0.52
5700	0.51	0.67			0.48	0.67	0.36	0.58	0.82			0.58	0.82	0.82	0.44
6000	0.44	0.61			0.41	0.61	0.31	0.51	0.74			0.49	0.72	0.74	0.38

Bridging > Span mm	Z/C 10015 (kN/m)						Z/C 10019 (kN/m)									
	INWARD			OUTWARD			L/150	INWARD			OUTWARD			L/150		
	0	1, 2, 3		0	1	2		3	0	1, 2, 3		0	1		2	3
2100	7.48	7.88		7.88	7.88	7.88	7.88	10.26	10.14	10.99		10.99	10.99	10.99	10.99	13.61
2400	5.60	6.03		6.03	6.03	6.03	6.03	6.91	7.50	8.41		8.41	8.41	8.41	8.41	9.18
2700	4.33	4.77		4.55	4.77	4.77	4.77	4.94	5.75	6.65		6.45	6.65	6.65	6.65	6.47
3000	3.44	3.86		3.50	3.86	3.86	3.86	3.67	4.54	5.38		4.90	5.38	5.38	5.38	4.75
3300	2.80	3.19		2.74	3.19	3.19	3.19	2.80	3.66	4.45		3.78	4.45	4.45	4.45	3.59
3600	2.31	2.68		2.15	2.68	2.68	2.68	2.18	3.01	3.74		2.96	3.74	3.74	3.74	2.79
3900	1.93	2.28		1.70	2.24	2.28	2.28	1.72	2.50	3.19		2.30	3.17	3.19	3.19	2.20
Sections below exceed the normal delivery length of 12000mm																
4200	1.64	1.97		1.34	1.86	1.97	1.97	1.38	2.09	2.75		1.83	2.65	2.75	2.75	1.76
4500	1.39	1.72		1.07	1.56	1.72	1.72	1.13	1.78	2.39		1.46	2.20	2.39	2.39	1.43
4800	1.19	1.51		0.87	1.32	1.51	1.51	0.93	1.52	2.10		1.18	1.85	2.10	2.10	1.18
5100	1.03	1.34		0.71	1.13	1.34	1.34	0.78	1.32	1.86		0.96	1.56	1.86	1.86	0.98
5400	0.90	1.19		0.59	0.96	1.17	1.19	0.66	1.15	1.66		0.80	1.32	1.66	1.66	0.83
5700	0.78	1.07		0.49	0.81	1.02	1.07	0.56	1.01	1.49		0.67	1.11	1.45	1.49	0.70
6000	0.69	0.97		0.41	0.69	0.90	0.97	0.48	0.88	1.35		0.57	0.95	1.27	1.35	0.60

Bold capacities require grade 8.8 purlin bolts.

Values above dotted horizontal line in body of table are governed by the strength of the grade 8.8 bolt.

INWARD = Inward load capacity. OUTWARD = Outward load capacity. L/150 = Load for deflection span/150.

See also: Design notes for capacity tables.

Three Continuous Spans

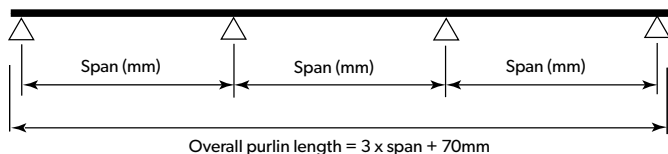

THREE CONTINUOUS SPANS

Bridging > Span mm	Z/C 15012 (kN/m)						Z/C 15015 (kN/m)							
	INWARD			OUTWARD			L/150	INWARD			OUTWARD			L/150
	0	1, 2, 3		0	1	2, 3		0	1, 2, 3		0	1	2, 3	
2100	7.13	7.13		7.13	7.13	7.13	21.75	11.84	11.84		11.84	11.84	11.84	29.55
2400	5.97	5.97		5.97	5.97	5.97	14.57	9.65	9.65		9.65	9.65	9.65	19.80
2700	5.06	5.06		5.06	5.06	5.06	10.23	7.99	7.99		7.99	7.99	7.99	13.90
3000	4.35	4.35		4.35	4.35	4.35	7.46	6.38	6.72		6.72	6.72	6.72	10.14
3300	3.77	3.77		3.77	3.77	3.77	5.61	5.13	5.63		5.63	5.63	5.63	7.62
3600	3.30	3.30		3.30	3.30	3.30	4.41	4.20	4.73		4.72	4.73	4.73	5.88
3900	2.91	2.91		2.91	2.91	2.91	3.55	3.47	4.03		3.80	4.03	4.03	4.67

Sections below exceed the normal delivery length of 12000mm

4200	2.46	2.58		2.38	2.58	2.58	2.90	2.90	3.47		3.08	3.47	3.47	3.77
4500	2.09	2.30		1.90	2.30	2.30	2.40	2.46	3.03		2.47	3.03	3.03	3.09
4800	1.78	2.03		1.54	2.03	2.03	1.99	2.05	2.66		1.96	2.66	2.66	2.57
5100	1.54	1.79		1.26	1.79	1.79	1.67	1.78	2.36		1.63	2.36	2.36	2.15
5400	1.33	1.60		1.04	1.60	1.60	1.42	1.56	2.10		1.37	2.10	2.10	1.83
5700	1.17	1.44		0.87	1.43	1.44	1.21	1.37	1.89		1.16	1.83	1.89	1.57
6000	1.02	1.30		0.73	1.24	1.30	1.05	1.21	1.70		0.99	1.58	1.70	1.36
6300	0.90	1.18		0.61	1.05	1.18	0.91	1.08	1.54		0.84	1.38	1.54	1.18

Bridging > Span mm	Z/C 15019 (kN/m)						Z/C 15024 (kN/m)							
	INWARD			OUTWARD			L/150	INWARD			OUTWARD			L/150
	0	1, 2, 3		0	1	2, 3		0	1, 2, 3		0	1	2, 3	
2100	17.77	17.77		17.77	17.77	17.77	38.56	22.44	22.44		22.44	22.44	22.44	51.42
2400	13.50	14.45		14.45	14.45	14.45	25.83	18.03	19.64		19.64	19.64	19.64	34.45
2700	10.32	11.70		11.70	11.70	11.70	18.14	13.58	16.70		16.70	16.70	16.70	24.19
3000	8.09	9.60		9.60	9.60	9.60	13.23	10.38	13.53		13.53	13.53	13.53	17.64
3300	6.46	7.93		7.74	7.93	7.93	9.94	8.11	11.18		10.94	11.18	11.18	13.25
3600	5.26	6.67		6.22	6.67	6.67	7.70	6.50	9.39		8.71	9.39	9.39	10.25
3900	4.36	5.68		5.06	5.68	5.68	6.14	5.31	8.00		7.03	8.00	8.00	8.11

Sections below exceed the normal delivery length of 12000mm

4200	3.64	4.90		4.16	4.90	4.90	4.98	4.42	6.90		5.75	6.90	6.90	6.54
4500	3.08	4.27		3.39	4.27	4.27	4.10	3.72	6.01		4.67	6.01	6.01	5.36
4800	2.64	3.75		2.76	3.75	3.75	3.42	3.18	5.28		3.75	5.28	5.28	4.44
5100	2.28	3.32		2.26	3.23	3.32	2.87	2.74	4.68		3.05	4.58	4.68	3.70
5400	1.99	2.96		1.87	2.79	2.96	2.42	2.39	4.18		2.51	3.94	4.18	3.12
5700	1.74	2.66		1.58	2.43	2.66	2.07	2.09	3.75		2.09	3.41	3.75	2.65
6000	1.54	2.40		1.32	2.13	2.40	1.78	1.85	3.38		1.76	2.97	3.38	2.27
6300	1.37	2.18		1.11	1.87	2.18	1.54	1.64	3.07		1.49	2.60	3.07	1.96

Bold capacities require grade 8.8 purlin bolts.

Values above dotted horizontal line in body of table are governed by the strength of the grade 8.8 bolt.

INWARD = Inward load capacity. OUTWARD = Outward load capacity. L/150 = Load for deflection span/150.

See also: Design notes for capacity tables.

Three Continuous Spans

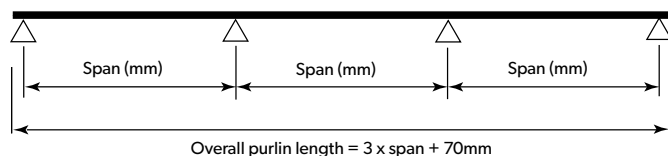

THREE CONTINUOUS SPANS

T200

Span mm	Z/C 20015 (kN/m)					Z/C 20019 (kN/m)					Z/C 20024 (kN/m)					
	INWARD		OUTWARD		L/150	INWARD		OUTWARD		L/150	INWARD		OUTWARD		L/150	
	0	1, 2, 3	0	1, 2, 3		0	1, 2, 3	0	1, 2, 3		0	1	2, 3			
2100	10.83	10.83	10.83	10.83	58.42	17.77	17.77	17.77	17.77	83.25	22.44	22.44	22.44	22.44	109.93	
2400	9.18	9.18	9.18	9.18	39.14	15.55	15.55	15.55	15.55	55.77	19.64	19.64	19.64	19.64	73.64	
2700	7.88	7.88	7.88	7.88	27.49	13.82	13.82	13.82	13.82	39.17	17.46	17.46	17.46	17.46	51.72	
3000	6.84	6.84	6.84	6.84	20.04	12.31	12.31	12.31	12.31	28.55	15.71	15.71	15.71	15.71	37.70	
3300	6.00	6.00	6.00	6.00	15.06	9.80	10.64	10.64	10.64	21.45	12.81	14.28	14.28	14.28	28.33	
3600	5.29	5.29	5.29	5.29	11.60	7.62	9.28	9.28	9.28	16.52	10.17	13.09	13.09	13.09	21.82	
3900	4.71	4.71	4.71	4.71	9.12	6.27	8.15	8.15	8.15	13.00	8.27	12.07	11.98	12.07	17.16	
Sections below exceed the normal delivery length of 12000mm																
4200	4.21	4.21	4.21	4.21	7.30	5.24	7.17	7.17	7.17	10.41	6.85	10.43	9.96	10.43	10.43	13.74
4500	3.56	3.78	3.78	3.78	5.94	4.45	6.25	6.11	6.25	8.46	5.77	9.09	8.35	9.09	9.09	11.17
4800	3.05	3.41	3.41	3.41	4.89	3.81	5.49	5.11	5.49	6.99	4.89	7.99	7.05	7.99	7.99	9.27
5100	2.64	3.10	2.97	3.10	4.10	3.31	4.87	4.23	4.87	5.87	4.18	7.07	5.95	7.07	7.07	7.81
5400	2.30	2.82	2.47	2.82	3.51	2.89	4.34	3.41	4.34	4.98	3.62	6.31	4.97	6.31	6.31	6.65
5700	2.02	2.56	2.06	2.56	3.04	2.55	3.90	2.89	3.90	4.26	3.16	5.66	4.16	5.66	5.66	5.71
6000	1.78	2.31	1.74	2.31	2.65	2.26	3.52	2.47	3.52	3.67	2.78	5.11	3.52	5.07	5.11	4.95
6300	1.58	2.09	1.48	2.09	2.32	2.01	3.19	2.13	3.19	3.19	2.46	4.64	3.00	4.49	4.64	4.30

Bold capacities require grade 8.8 purlin bolts.

Values above dotted horizontal line in body of table are governed by the strength of the grade 8.8 bolt.

INWARD = Inward load capacity. OUTWARD = Outward load capacity. L/150 = Load for deflection span/150.

See also: Design notes for capacity tables.

Three Continuous Spans

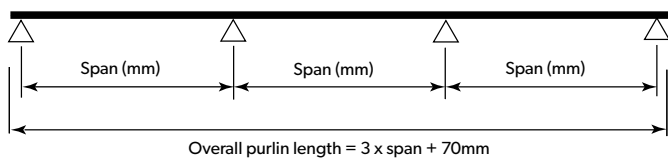

Bridging > Span mm	Z 10010 (kN/m)						L/150	Z 10010/10015 (kN/m)						L/150	Z 10012 (kN/m)						L/150			
	INWARD			OUTWARD				INWARD			OUTWARD				INWARD			OUTWARD						
	0	1, 2, 3		0	1	2		3	0	1, 2, 3		0	1		2	3	0	1, 2, 3		0		1	2	3
2100	6.62	6.62		6.62	6.62	6.62	6.62	6.99	8.93	9.28		9.28	9.28	9.28	9.28	10.87	7.73	8.06		8.06	8.06	8.06	8.06	8.62
2400	5.03	5.04		5.04	5.04	5.04	5.04	4.65	6.62	6.99		6.99	6.99	6.99	6.99	7.22	5.71	6.14		6.14	6.14	6.14	6.14	5.73
2700	3.86	3.96		3.93	3.96	3.96	3.96	3.30	5.06	5.24		5.24	5.24	5.24	5.24	5.07	4.37	4.83		4.65	4.83	4.83	4.83	4.02
3000	3.03	3.20		2.83	3.20	3.20	3.20	2.42	3.51	4.00		3.87	4.00	4.00	4.00	3.74	3.43	3.89		3.43	3.89	3.89	3.89	2.96
3300	2.41	2.63		2.06	2.63	2.63	2.63	1.84	2.76	3.15		2.82	3.15	3.15	3.15	2.85	2.73	3.20		2.50	3.20	3.20	3.20	2.24
3600	1.95	2.21		1.54	2.21	2.21	2.21	1.42	2.21	2.55		2.10	2.55	2.55	2.55	2.22	2.22	2.68		1.82	2.68	2.68	2.68	1.74
3900	1.60	1.87		1.17	1.87	1.87	1.87	1.13	1.80	2.10		1.60	2.10	2.10	2.10	1.75	1.83	2.28		1.42	2.28	2.28	2.28	1.38
4200	1.33	1.61		0.91	1.56	1.61	1.61	0.91	1.49	1.76		1.25	1.76	1.76	1.76	1.40	1.46	1.96		1.12	1.85	1.96	1.96	1.11
4500	1.12	1.40		0.71	1.25	1.40	1.40	0.74	1.24	1.50		0.99	1.50	1.50	1.50	1.14	1.24	1.71		0.90	1.52	1.71	1.71	0.91
4800	0.94	1.23		0.57	1.01	1.23	1.23	0.62	1.05	1.29		0.80	1.29	1.29	1.29	0.94	1.05	1.50		0.73	1.23	1.50	1.50	0.76
5100	0.80	1.07		0.47	0.82	1.07	1.07	0.52	0.89	1.13		0.66	1.08	1.13	1.13	0.79	0.90	1.30		0.59	0.96	1.30	1.30	0.64
5400	0.68	0.94			0.67	0.94	0.94	0.44	0.76	0.99		0.53	0.90	0.99	0.99	0.67	0.77	1.15		0.48	0.80	1.13	1.15	0.54
5700	0.58	0.83			0.56	0.81	0.83	0.37	0.65	0.88		0.45	0.75	0.88	0.88	0.57	0.67	1.02		0.40	0.67	0.97	1.02	0.46
6000	0.50	0.74			0.47	0.69	0.74	0.32	0.56	0.78		0.63	0.78	0.78	0.78	0.48	0.58	0.91		0.57	0.83	0.91	0.91	0.40
6300	0.45	0.72			0.41	0.60	0.72	0.28	0.52	0.78		0.56	0.78	0.78	0.78	0.42	0.53	0.87		0.50	0.74	0.87	0.87	0.35
6600		0.65				0.52	0.65	0.25	0.45	0.70		0.48	0.69	0.70	0.70	0.37	0.47	0.79		0.43	0.63	0.78	0.78	0.30
6900		0.60				0.44	0.58	0.22		0.63		0.41	0.60	0.63	0.63	0.32	0.41	0.73			0.52	0.69	0.69	0.27

Bridging > Span mm	Z 10012/10019 (kN/m)						L/150	Z 10015 (kN/m)						L/150	Z 10019 (kN/m)						L/150				
	INWARD			OUTWARD				INWARD			OUTWARD				INWARD			OUTWARD							
	0	1, 2, 3		0	1	2		3	0	1	2, 3	0	1		2	3	0	1	2, 3	0		1	2	3	
2100	10.51	12.69		12.69	12.69	12.69	12.69	14.36	9.23	10.51	10.51	10.51	10.51	10.51	11.28	12.16	14.65	14.65		14.65	14.65	14.65	14.65	14.96	
2400	7.32	8.82		8.82	8.82	8.82	8.82	9.54	6.84	8.00	8.00	8.00	8.00	8.00	7.51	8.87	11.16	11.16		11.01	11.16	11.16	11.16	9.96	
2700	5.38	6.43		6.43	6.43	6.43	6.43	6.70	5.25	6.29	6.29	6.29	6.29	6.29	5.24	6.66	8.77	8.77		8.08	8.77	8.77	8.77	6.95	
3000	4.10	4.90		4.76	4.90	4.90	4.90	4.88	4.13	5.07	5.07	5.07	5.07	5.07	3.85	5.18	7.07	7.07		6.02	7.07	7.07	7.07	5.08	
3300	3.22	3.86		3.56	3.86	3.86	3.86	3.67	3.32	4.18	4.18	4.18	4.18	4.18	2.93	4.14	5.83	5.83		4.54	5.83	5.83	5.83	3.82	
3600	2.59	3.12		2.71	3.12	3.12	3.12	2.83	2.71	3.50	3.50	3.50	3.50	3.50	2.28	3.37	4.88	4.88		3.43	4.87	4.88	4.88	2.94	
3900	2.12	2.58		2.09	2.58	2.58	2.58	2.23	2.25	2.97	2.97	2.97	2.97	2.97	1.82	2.80	4.15	4.15		2.63	3.99	4.15	4.15	2.32	
4200	1.75	2.16		1.58	2.16	2.16	2.16	1.78	1.90	2.56	2.56	2.56	2.56	2.56	1.46	2.35	3.57	3.57		2.04	3.26	3.57	3.57	1.87	
4500	1.47	1.84		1.27	1.84	1.84	1.84	1.45	1.61	2.22	2.22	2.22	2.22	2.22	1.18	1.99	3.10	3.10		1.61	2.69	3.10	3.10	1.51	
4800	1.24	1.59		1.04	1.59	1.59	1.59	1.19	1.38	1.95	1.95	1.95	1.95	1.95	0.98	1.70	2.72	2.72		1.29	2.24	2.72	2.72	1.24	
5100	1.02	1.38		0.87	1.34	1.38	1.38	0.99	1.18	1.70	1.70	1.70	1.70	1.70	0.82	1.46	2.37	2.37		1.05	1.85	2.32	2.37	1.03	
5400	0.87	1.21		0.73	1.14	1.21	1.21	0.83	1.01	1.49	1.49	1.49	1.49	1.49	0.69	1.27	2.08	2.08		0.86	1.52	1.99	2.08	0.87	
5700	0.76	1.07		0.62	0.98	1.07	1.07	0.71	0.88	1.32	1.32	1.32	1.32	1.32	0.59	1.10	1.84	1.85		0.72	1.28	1.70	1.85	0.74	
6000	0.66	0.96		0.53	0.83	0.96	0.96	0.60	0.76	1.18	1.18	1.18	1.18	1.17	0.50	0.97	1.63	1.65		0.61	1.07	1.47	1.65	0.63	
6300	0.62	0.96		0.48	0.72	0.96	0.96	0.53	0.68	1.11	1.14		0.68	0.96	1.09	0.44	0.87	1.53	1.59		0.53	0.93	1.33	1.55	0.55
6600	0.54	0.86		0.42	0.62	0.85	0.86	0.46	0.60	1.00	1.03		0.58	0.84	0.97	0.38	0.77	1.38	1.44		0.45	0.79	1.17	1.37	0.48
6900	0.48	0.78			0.54	0.75	0.78	0.40	0.53	0.90	0.95		0.50	0.74	0.86	0.34	0.69	1.24	1.32		0.68	1.01	1.22	1.42	0.42
7200	0.42	0.71			0.47	0.66	0.71	0.35	0.47	0.82	0.87		0.43	0.65	0.77	0.29	0.61	1.13	1.21		0.58	0.88	1.08	1.37	0.37
7500		0.64			0.41	0.59	0.64	0.31	0.42	0.74	0.79			0.57	0.69	0.26	0.55	1.02	1.10		0.50	0.77	0.96	1.33	0.33
7800		0.59				0.52	0.59	0.28		0.67	0.72			0.49	0.62	0.23	0.49	0.92	1.01		0.44	0.67	0.85	1.29	0.29

Bold capacities require grade 8.8 purlin bolts.

Values above dotted horizontal line in body of table are governed by the strength of the grade 8.8 bolt.

INWARD = Inward load capacity. OUTWARD = Outward load capacity. L/150 = Load for deflection span/150.

See also: Design notes for capacity tables.

Three Lapped Spans

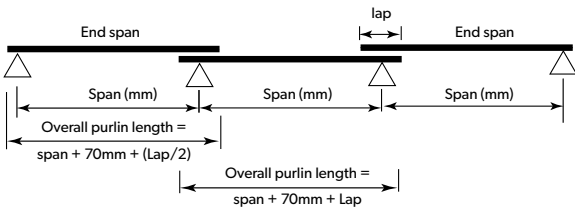

Bridging > Span mm	Z/C 15012 (kN/m)							Z/C 15015 (kN/m)								
	INWARD			OUTWARD				L/150	INWARD			OUTWARD				L/150
	0	1, 2, 3		0	1	2	3		0	1	2, 3	0	1	2	3	
3000	6.16	6.93		6.93	6.93	6.93	6.93	8.22	7.08	9.10	9.10	9.10	9.10	9.10	9.10	11.17
3300	4.89	5.70		5.70	5.70	5.70	5.70	6.15	5.64	7.49	7.49	7.49	7.49	7.49	7.49	8.35
3600	3.97	4.77		4.68	4.77	4.77	4.77	4.71	4.59	6.27	6.27	5.94	6.27	6.27	6.27	6.40
3900	3.27	4.05		3.62	4.05	4.05	4.05	3.69	3.80	5.32	5.32	4.69	5.32	5.32	5.32	5.02
4200	2.74	3.48		2.82	3.48	3.48	3.48	2.98	3.20	4.58	4.58	3.56	4.58	4.58	4.58	4.00
4500	2.32	3.03		2.24	3.03	3.03	3.03	2.47	2.72	3.98	3.98	2.87	3.98	3.98	3.98	3.27
4800	1.99	2.65		1.79	2.65	2.65	2.65	2.07	2.34	3.49	3.49	2.34	3.49	3.49	3.49	2.71
5100	1.72	2.35		1.46	2.35	2.35	2.35	1.76	2.04	3.08	3.08	1.94	3.08	3.08	3.08	2.27
5400	1.50	2.09		1.20	2.06	2.09	2.09	1.49	1.78	2.74	2.74	1.61	2.63	2.74	2.74	1.92
5700	1.31	1.87		0.98	1.75	1.87	1.87	1.27	1.57	2.46	2.46	1.34	2.25	2.46	2.46	1.64
6000	1.15	1.69		0.83	1.47	1.69	1.69	1.10	1.39	2.21	2.21	1.12	1.92	2.21	2.21	1.41
6300	1.02	1.53		0.71	1.25	1.53	1.53	0.95	1.24	2.00	2.00	0.95	1.63	2.00	2.00	1.23
6600	0.90	1.39		0.61	1.07	1.39	1.39	0.83	1.11	1.82	1.82	0.80	1.36	1.82	1.82	1.07
6900	0.81	1.27		0.52	0.92	1.27	1.27	0.73	1.00	1.67	1.67	0.68	1.19	1.65	1.67	0.95
7200	0.72	1.16		0.45	0.79	1.15	1.16	0.64	0.89	1.53	1.53	0.58	1.04	1.47	1.53	0.84
7500	0.64	1.06			0.68	1.02	1.06	0.57	0.80	1.39	1.39	0.50	0.91	1.30	1.39	0.75
7800	0.58	0.97			0.60	0.89	0.97	0.51	0.72	1.28	1.28	0.43	0.80	1.16	1.28	0.67
8100	0.52	0.89			0.52	0.78	0.89	0.46	0.65	1.17	1.17		0.71	1.02	1.17	0.60
8400	0.47	0.82			0.46	0.69	0.82	0.41	0.59	1.08	1.08		0.62	0.91	1.08	0.54
8700	0.42	0.76			0.40	0.61	0.76	0.37	0.54	1.00	1.00		0.55	0.80	0.99	0.49
9000		0.71				0.55	0.70	0.34	0.49	0.93	0.93		0.49	0.70	0.90	0.44
9300		0.70				0.50	0.66	0.31	0.45	0.89	0.92		0.45	0.65	0.85	0.40
9600		0.65				0.45	0.60	0.28	0.42	0.82	0.86		0.40	0.59	0.78	0.37
9900		0.61				0.40	0.54	0.26		0.76	0.80			0.53	0.70	0.33

Bold capacities require grade 8.8 purlin bolts.

Values above dotted horizontal line in body of table are governed by the strength of the grade 8.8 bolt.

INWARD = Inward load capacity. OUTWARD = Outward load capacity. L/150 = Load for deflection span/150.

See also: Design notes for capacity tables.

Three Lapped Spans

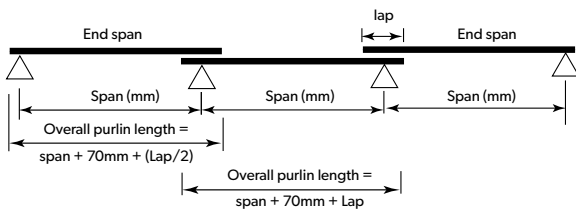

Bridging > Span mm	Z 15012/15019 (kN/m)							Z 15015/15024 (kN/m)								
	INWARD			OUTWARD				L/150	INWARD			OUTWARD				L/150
	0	1, 2, 3	0	1	2	3	0		1, 2, 3	0	1	2	3			
3000	8.29	8.29	8.29	8.29	8.29	8.29	13.97	9.79	13.52	13.52	13.52	13.52	13.52	18.65		
3300	6.12	6.87	6.87	6.87	6.87	6.87	10.44	7.50	10.88	10.88	10.88	10.88	10.88	13.93		
3600	4.86	5.78	5.78	5.78	5.78	5.78	8.00	5.92	8.92	8.84	8.92	8.92	8.92	10.67		
3900	3.94	4.92	4.92	4.92	4.92	4.92	6.29	4.79	7.28	6.86	7.28	7.28	7.28	8.38		
4200	3.25	4.23	4.12	4.23	4.23	4.23	5.08	3.95	5.99	5.43	5.99	5.99	5.99	6.72		
4500	2.73	3.68	3.25	3.68	3.68	3.68	4.17	3.31	5.02	4.32	5.02	5.02	5.02	5.48		
4800	2.32	3.22	2.60	3.22	3.22	3.22	3.46	2.81	4.27	3.47	4.27	4.27	4.27	4.54		
5100	1.99	2.79	2.11	2.79	2.79	2.79	2.91	2.42	3.67	2.77	3.67	3.67	3.67	3.78		
5400	1.72	2.43	1.74	2.43	2.43	2.43	2.46	2.09	3.20	2.31	3.20	3.20	3.20	3.18		
5700	1.50	2.13	1.44	2.13	2.13	2.13	2.09	1.83	2.81	1.94	2.81	2.81	2.81	2.70		
6000	1.31	1.89	1.21	1.89	1.89	1.89	1.79	1.61	2.48	1.65	2.48	2.48	2.48	2.30		
6300	1.16	1.68	1.03	1.68	1.68	1.68	1.55	1.43	2.21	1.42	2.20	2.21	2.21	1.99		
6600	1.03	1.51	0.88	1.48	1.51	1.51	1.35	1.27	1.99	1.23	1.92	1.99	1.99	1.72		
6900	0.91	1.36	0.76	1.29	1.36	1.36	1.19	1.14	1.79	1.07	1.69	1.79	1.79	1.51		
7200	0.82	1.23	0.65	1.12	1.23	1.23	1.05	1.02	1.62	0.93	1.49	1.62	1.62	1.32		
7500	0.73	1.12	0.57	0.97	1.12	1.12	0.93	0.92	1.48	0.82	1.31	1.48	1.48	1.17		
7800	0.66	1.03	0.50	0.85	1.03	1.03	0.82	0.83	1.35	0.72	1.15	1.35	1.35	1.04		
8100	0.59	0.94	0.45	0.75	0.94	0.94	0.74	0.75	1.24	0.64	1.02	1.24	1.24	0.93		
8400	0.53	0.87	0.40	0.66	0.87	0.87	0.66	0.68	1.14	0.57	0.88	1.14	1.14	0.83		
8700	0.48	0.80		0.59	0.80	0.80	0.59	0.62	1.06	0.51	0.79	1.06	1.06	0.75		
9000	0.44	0.75		0.53	0.74	0.75	0.53	0.56	0.98	0.45	0.71	0.97	0.98	0.67		
9300	0.41	0.75		0.48	0.71	0.75	0.49	0.53	0.98	0.42	0.67	0.93	0.98	0.62		
9600		0.69		0.43	0.64	0.69	0.44	0.49	0.91		0.60	0.85	0.91	0.56		
9900		0.65			0.58	0.65	0.41	0.45	0.85		0.55	0.77	0.85	0.51		
10200		0.60			0.52	0.60	0.37	0.41	0.80		0.50	0.70	0.80	0.47		
10500		0.57			0.47	0.57	0.34		0.74		0.46	0.64	0.74	0.43		

Bold capacities require grade 8.8 purlin bolts.
 Values above dotted horizontal line in body of table are governed by the strength of the grade 8.8 bolt.
 INWARD = Inward load capacity. OUTWARD = Outward load capacity. L/150 = Load for deflection span/150.
 See also: Design notes for capacity tables.
 Note: In mixed spans, the thicker sections is used in the end span.

Three Lapped Spans

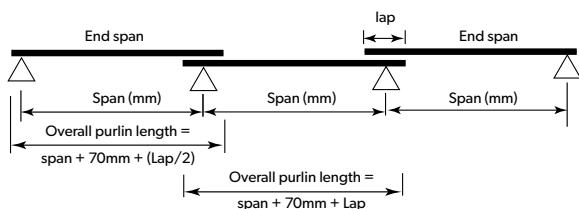

Bridging > Span mm	Z 15019 (kN/m)								L/150	Z 15024 (kN/m)								L/150
	INWARD				OUTWARD					INWARD				OUTWARD				
	0	1	2	3	0	1	2	3		0	1	2	3	0	1	2	3	
3000	9.20	12.83	12.83	12.83	12.69	12.83	12.83	12.83	14.57	11.31	18.08	18.08	18.08	18.00	18.08	18.08	18.08	19.43
3300	7.22	10.56	10.56	10.56	9.94	10.56	10.56	10.56	10.90	8.78	14.88	14.88	14.88	13.94	14.88	14.88	14.88	14.53
3600	5.82	8.84	8.84	8.84	7.90	8.84	8.84	8.84	8.36	7.01	12.46	12.46	12.46	10.97	12.46	12.46	12.46	11.14
3900	4.78	7.51	7.51	7.51	6.33	7.51	7.51	7.51	6.54	5.71	10.58	10.58	10.58	8.75	10.58	10.58	10.58	8.73
4200	4.00	6.45	6.45	6.45	5.05	6.45	6.45	6.45	5.23	4.74	9.09	9.09	9.09	6.87	9.09	9.09	9.09	6.98
4500	3.39	5.61	5.61	5.61	4.00	5.60	5.61	5.61	4.29	3.99	7.90	7.90	7.90	5.39	7.90	7.90	7.90	5.68
4800	2.91	4.92	4.92	4.92	3.21	4.76	4.92	4.92	3.57	3.41	6.92	6.92	6.92	4.29	6.74	6.92	6.92	4.70
5100	2.51	4.34	4.34	4.34	2.62	4.07	4.34	4.34	3.00	2.94	6.07	6.12	6.12	3.46	5.73	6.12	6.12	3.93
5400	2.19	3.86	3.87	3.87	2.15	3.50	3.87	3.87	2.55	2.56	5.31	5.45	5.45	2.82	4.90	5.45	5.45	3.33
5700	1.92	3.42	3.46	3.46	1.76	3.03	3.46	3.46	2.19	2.24	4.68	4.88	4.88	2.33	4.21	4.88	4.88	2.82
6000	1.69	3.05	3.12	3.12	1.47	2.62	3.12	3.12	1.88	1.98	4.15	4.40	4.40	1.95	3.64	4.40	4.40	2.42
6300	1.50	2.73	2.83	2.83	1.23	2.25	2.77	2.83	1.62	1.76	3.71	3.98	3.98	1.64	3.13	3.93	3.98	2.08
6600	1.33	2.46	2.57	2.57	1.04	1.94	2.46	2.57	1.41	1.58	3.33	3.62	3.62	1.39	2.66	3.48	3.62	1.81
6900	1.19	2.23	2.35	2.35	0.89	1.66	2.19	2.35	1.24	1.41	3.00	3.31	3.31	1.19	2.27	3.08	3.31	1.58
7200	1.07	2.03	2.15	2.16	0.76	1.44	1.96	2.16	1.09	1.28	2.72	3.04	3.04	1.03	1.95	2.75	3.04	1.39
7500	0.97	1.84	1.96	1.96	0.66	1.25	1.75	1.96	0.97	1.15	2.46	2.77	2.77	0.89	1.68	2.44	2.77	1.22
7800	0.87	1.67	1.80	1.80	0.57	1.09	1.56	1.77	0.86	1.05	2.23	2.53	2.53	0.78	1.46	2.17	2.5	1.09
8100	0.79	1.52	1.65	1.65	0.50	0.96	1.40	1.60	0.77	0.96	2.04	2.33	2.33	0.69	1.28	1.95	2.26	0.97
8400	0.72	1.40	1.52	1.52	0.44	0.84	1.25	1.45	0.69	0.87	1.86	2.14	2.14	0.61	1.12	1.74	2.04	0.87
8700	0.65	1.28	1.41	1.41		0.74	1.12	1.31	0.62	0.80	1.71	1.98	1.98	0.54	0.99	1.55	1.85	0.78
9000	0.60	1.18	1.31	1.31		0.65	1.00	1.20	0.56	0.73	1.58	1.84	1.84	0.48	0.87	1.38	1.68	0.70
9300	0.55	1.14	1.29	1.29		0.59	0.91	1.14	0.51	0.69	1.51	1.82	1.82	0.44	0.79	1.25	1.60	0.64
9600	0.51	1.06	1.21	1.21		0.52	0.82	1.05	0.47	0.63	1.40	1.70	1.71		0.71	1.12	1.46	0.59
9900	0.47	0.98	1.13	1.13		0.47	0.73	0.96	0.42	0.58	1.30	1.58	1.59		0.63	1.00	1.33	0.53
10200	0.43	0.91	1.05	1.06		0.42	0.66	0.87	0.39	0.54	1.20	1.47	1.49		0.57	0.90	1.22	0.49
10500	0.40	0.85	0.97	0.99			0.60	0.79	0.35	0.50	1.12	1.36	1.39		0.51	0.81	1.11	0.45

Bold capacities require grade 8.8 purlin bolts.
 Values above dotted horizontal line in body of table are governed by the strength of the grade 8.8 bolt.
 INWARD = Inward load capacity. OUTWARD = Outward load capacity. L/150 = Load for deflection span/150.
 See also: Design notes for capacity tables.

Three Lapped Spans

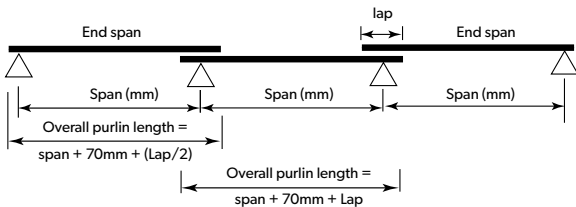

Bridging > Span mm	Z 20015 (kN/m)							L/150	Z 20015/20024 (kN/m)							L/150
	INWARD			OUTWARD					INWARD	OUTWARD				L/150		
	0	1, 2, 3	0	1	2	3	0			1	2	3				
3000	10.60	10.60	10.60	10.60	10.60	10.60	10.60	22.08	12.73	12.73	12.73	12.73	12.73	12.73	12.73	39.72
3300	8.44	9.13	9.13	9.13	9.13	9.13	9.13	16.51	10.70	10.70	10.70	10.70	10.70	10.70	10.70	29.66
3600	6.77	7.95	7.95	7.95	7.95	7.95	7.95	12.66	8.67	9.12	9.12	9.12	9.12	9.12	9.12	22.72
3900	5.55	6.97	6.97	6.97	6.97	6.97	6.97	9.92	6.94	7.86	7.86	7.86	7.86	7.86	7.86	17.79
4200	4.62	6.15	6.15	6.15	6.15	6.15	6.15	7.91	5.68	6.84	6.84	6.84	6.84	6.84	6.84	14.18
4500	3.91	5.39	5.21	5.39	5.39	5.39	5.39	6.41	4.73	6.00	6.00	6.00	6.00	6.00	6.00	11.48
4800	3.34	4.73	4.27	4.73	4.73	4.73	4.73	5.26	4.00	5.30	5.30	5.30	5.30	5.30	5.30	9.43
5100	2.89	4.18	3.48	4.18	4.18	4.18	4.18	4.37	3.42	4.71	4.71	4.71	4.71	4.71	4.71	7.90
5400	2.52	3.72	2.87	3.72	3.72	3.72	3.72	3.67	2.96	4.21	4.21	4.21	4.21	4.21	4.21	6.71
5700	2.21	3.33	2.38	3.33	3.33	3.33	3.33	3.12	2.58	3.79	3.79	3.79	3.79	3.79	3.79	5.75
6000	1.96	3.00	2.00	3.00	3.00	3.00	3.00	2.70	2.27	3.37	3.37	3.37	3.37	3.37	3.37	4.97
6300	1.74	2.72	1.69	2.72	2.72	2.72	2.72	2.36	2.00	3.01	3.01	3.01	3.01	3.01	3.01	4.32
6600	1.55	2.47	1.39	2.46	2.47	2.47	2.47	2.08	1.78	2.70	2.70	2.70	2.70	2.70	2.70	3.76
6900	1.40	2.26	1.21	2.17	2.26	2.26	2.26	1.85	1.60	2.43	2.43	2.43	2.43	2.43	2.43	3.29
7200	1.21	2.07	1.05	1.91	2.07	2.07	2.07	1.65	1.44	2.21	2.21	2.21	2.21	2.21	2.21	2.90
7500	1.09	1.89	0.92	1.66	1.89	1.89	1.89	1.48	1.30	2.01	2.01	2.01	2.01	2.01	2.01	2.57
7800	0.99	1.73	0.81	1.45	1.73	1.73	1.73	1.33	1.17	1.84	1.84	1.84	1.84	1.84	1.84	2.29
8100	0.90	1.59	0.71	1.27	1.59	1.59	1.59	1.19	1.07	1.69	1.69	1.69	1.69	1.69	1.69	2.05
8400	0.83	1.46	0.63	1.12	1.46	1.46	1.46	1.07	0.97	1.55	1.55	1.55	1.55	1.55	1.55	1.85
8700	0.76	1.35	0.56	0.99	1.35	1.35	1.35	0.97	0.89	1.44	1.44	1.44	1.44	1.44	1.44	1.66
9000	0.69	1.26	0.49	0.88	1.26	1.26	1.26	0.88	0.82	1.33	1.33	1.33	1.33	1.33	1.33	1.50
9300	0.65	1.24	0.45	0.81	1.19	1.24	1.24	0.80	0.75	1.34	1.34	1.34	1.34	1.34	1.34	1.37
9600	0.60	1.17	0.40	0.72	1.09	1.17	1.17	0.73	0.69	1.24	1.24	1.24	1.24	1.24	1.24	1.25
9900	0.56	1.09		0.62	0.98	1.09	1.09	0.67	0.64	1.16	1.16	1.16	1.16	1.16	1.16	1.14
10200	0.52	1.02		0.56	0.88	1.02	1.02	0.61	0.59	1.08	1.08	1.08	1.08	1.08	1.08	1.04
10500	0.48	0.95		0.51	0.80	0.95	0.95	0.56	0.54	1.01	1.01	1.01	1.01	1.01	1.01	0.95
10800	0.44	0.89		0.47	0.72	0.89	0.89	0.52	0.51	0.95	0.95	0.95	0.95	0.95	0.95	0.87
Sections below exceed the normal delivery length of 12000mm																
11100	0.41	0.84		0.43	0.66	0.84	0.84	0.48	0.47	0.89	0.89	0.89	0.89	0.89	0.89	0.80
11400		0.79			0.60	0.78	0.78	0.44	0.44	0.84		0.61	0.84	0.84	0.84	0.74
11700		0.74			0.55	0.72	0.72	0.41	0.41	0.79		0.56	0.79	0.79	0.79	0.69
12000		0.70			0.50	0.67	0.67	0.38		0.75		0.52	0.74	0.75	0.75	0.64

Bold capacities require grade 8.8 purlin bolts.

Values above dotted horizontal line in body of table are governed by the strength of the grade 8.8 bolt.

INWARD = Inward load capacity. OUTWARD = Outward load capacity. L/150 = Load for deflection span/150.

See also: Design notes for capacity tables.

Note: In mixed spans, the thicker sections is used in the end span.

Three Lapped Spans

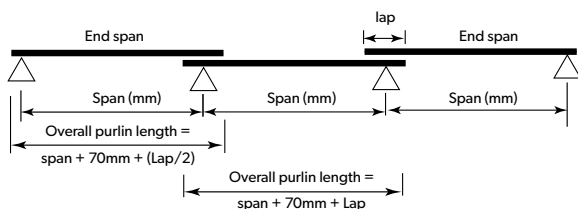

Bridging > Span mm	Z 20019 (kN/m)								L/150	Z 20024 (kN/m)								L/150
	INWARD				OUTWARD					INWARD				OUTWARD				
	0	1	2, 3		0	1	2	3		0	1	2, 3		0	1	2	3	
3000	13.75	18.79	18.79		18.79	18.79	18.79	18.79	31.46	18.42	19.78	19.78		19.78	19.78	19.78	19.78	41.54
3300	10.77	15.47	15.47		15.47	15.47	15.47	15.47	23.52	14.22	17.99	17.99		17.99	17.99	17.99	17.99	31.06
3600	8.66	12.95	12.95		12.95	12.95	12.95	12.95	18.04	11.13	16.50	16.50		16.50	16.50	16.50	16.50	23.82
3900	7.10	11.00	11.00		11.00	11.00	11.00	11.00	14.13	8.94	15.24	15.24		15.24	15.24	15.24	15.24	18.66
4200	5.93	9.45	9.45		9.18	9.45	9.45	9.45	11.27	7.32	13.74	13.74		12.55	13.74	13.74	13.74	14.88
4500	5.02	8.21	8.21		7.52	8.21	8.21	8.21	9.13	6.09	11.94	11.94		10.41	11.94	11.94	11.94	12.06
4800	4.29	7.20	7.20		6.07	7.20	7.20	7.20	7.50	5.15	10.47	10.47		8.58	10.47	10.47	10.47	9.90
5100	3.69	6.36	6.36		4.84	6.36	6.36	6.36	6.23	4.41	9.25	9.25		6.98	9.25	9.25	9.25	8.23
5400	3.21	5.66	5.66		4.04	5.66	5.66	5.66	5.24	3.81	8.23	8.23		5.75	8.23	8.23	8.23	6.93
5700	2.81	5.07	5.07		3.41	5.07	5.07	5.07	4.47	3.32	7.27	7.38		4.80	7.25	7.38	7.38	5.94
6000	2.48	4.57	4.57		2.90	4.57	4.57	4.57	3.85	2.92	6.46	6.64		4.02	6.35	6.64	6.64	5.13
6300	2.20	4.14	4.14		2.48	4.09	4.14	4.14	3.34	2.59	5.77	6.02		3.36	5.60	6.02	6.02	4.46
6600	1.97	3.77	3.77		2.10	3.59	3.77	3.77	2.91	2.31	5.18	5.47		2.84	4.95	5.47	5.47	3.91
6900	1.77	3.44	3.44		1.80	3.15	3.44	3.44	2.56	2.07	4.67	5.00		2.42	4.39	5.00	5.00	3.45
7200	1.59	3.16	3.16		1.55	2.74	3.16	3.16	2.26	1.86	4.24	4.59		2.07	3.88	4.59	4.59	3.04
7500	1.44	2.88	2.88		1.35	2.30	2.88	2.88	2.01	1.69	3.83	4.18		1.78	3.40	4.17	4.18	2.69
7800	1.31	2.63	2.63		1.17	2.03	2.63	2.63	1.79	1.53	3.47	3.83		1.55	2.97	3.75	3.83	2.40
8100	1.19	2.42	2.42		1.02	1.79	2.42	2.42	1.61	1.40	3.17	3.52		1.35	2.60	3.39	3.52	2.14
8400	1.09	2.22	2.23		0.89	1.59	2.23	2.23	1.45	1.28	2.90	3.24		1.18	2.30	3.07	3.24	1.93
8700	1.00	2.03	2.06		0.78	1.42	2.03	2.06	1.31	1.17	2.66	3.00		1.04	2.04	2.78	3.00	1.74
9000	0.92	1.87	1.91		0.69	1.27	1.84	1.91	1.19	1.08	2.45	2.78		0.92	1.81	2.54	2.78	1.58
9300	0.86	1.79	1.89		0.62	1.18	1.74	1.89	1.09	1.00	2.35	2.75		0.84	1.66	2.42	2.73	1.44
9600	0.79	1.66	1.78		0.56	1.07	1.56	1.78	1.00	0.93	2.17	2.58		0.75	1.47	2.21	2.52	1.32
9900	0.73	1.54	1.66		0.50	0.96	1.41	1.66	0.91	0.86	2.01	2.41		0.67	1.32	2.00	2.32	1.20
10200	0.68	1.43	1.55		0.45	0.86	1.23	1.55	0.84	0.80	1.86	2.25		0.60	1.18	1.82	2.14	1.10
10500	0.63	1.33	1.45		0.40	0.78	1.12	1.44	0.77	0.74	1.73	2.10		0.54	1.06	1.64	1.97	1.00
10800	0.58	1.24	1.36		0.70	1.02	1.33	1.33	0.71	0.69	1.61	1.96		0.49	0.95	1.49	1.82	0.92
Sections below exceed the normal delivery length of 12000mm																		
11100	0.54	1.15	1.28		0.64	0.93	1.23	1.23	0.66	0.65	1.50	1.84		0.45	0.86	1.36	1.69	0.85
11400	0.50	1.08	1.21		0.58	0.86	1.13	1.13	0.61	0.60	1.40	1.72		0.41	0.78	1.24	1.57	0.78
11700	0.47	1.00	1.14		0.53	0.79	1.05	1.05	0.56	0.56	1.31	1.62		0.71	1.13	1.46	1.46	0.72

Bold capacities require grade 8.8 purlin bolts.

Values above dotted horizontal line in body of table are governed by the strength of the grade 8.8 bolt.

INWARD = Inward load capacity. OUTWARD = Outward load capacity. L/150 = Load for deflection span/150.

See also: Design notes for capacity tables.

Three Lapped Spans

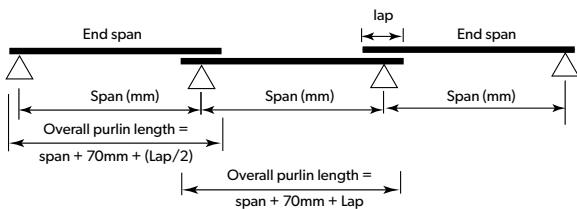

Span mm	Z 25019 (kN/m)								L/150
	INWARD			OUTWARD					
	0	1	2, 3	0	1	2	3		
3000	17.28	17.28	17.28	17.28	17.28	17.28	17.28	51.10	
3300	13.93	15.00	15.00	15.00	15.00	15.00	15.00	38.21	
3600	11.15	13.16	13.16	13.16	13.16	13.16	13.16	29.30	
3900	9.12	11.64	11.64	11.64	11.64	11.64	11.64	22.95	
4200	7.59	10.36	10.36	10.36	10.36	10.36	10.36	18.30	
4500	6.38	9.28	9.28	9.28	9.28	9.28	9.28	14.83	
4800	5.42	8.35	8.35	7.80	8.35	8.35	8.35	12.18	
5100	4.65	7.55	7.55	6.42	7.55	7.55	7.55	10.12	
5400	4.04	6.85	6.85	5.34	6.85	6.85	6.85	8.50	
5700	3.53	6.24	6.24	4.49	6.24	6.24	6.24	7.21	
6000	3.12	5.70	5.70	3.80	5.70	5.70	5.70	6.17	
6300	2.77	5.23	5.23	3.23	5.23	5.23	5.23	5.32	
6600	2.47	4.78	4.78	2.73	4.78	4.78	4.78	4.61	
6900	2.22	4.37	4.37	2.33	4.19	4.37	4.37	4.04	
7200	2.00	4.01	4.01	2.01	3.63	4.01	4.01	3.60	
7500	1.81	3.65	3.65	1.74	3.06	3.65	3.65	3.23	
7800	1.64	3.34	3.34	1.51	2.69	3.34	3.34	2.91	
8100	1.49	3.07	3.07	1.31	2.37	3.07	3.07	2.63	
8400	1.37	2.83	2.83	1.14	2.10	2.83	2.83	2.38	
8700	1.25	2.62	2.62	1.00	1.87	2.62	2.62	2.15	
9000	1.15	2.43	2.43	0.88	1.67	2.43	2.43	1.95	
9300	1.07	2.37	2.40	0.80	1.55	2.31	2.40	1.78	
9600	0.99	2.19	2.25	0.71	1.40	2.07	2.25	1.63	
9900	0.91	2.02	2.10	0.63	1.25	1.80	2.10	1.49	
10200	0.84	1.87	1.96	0.56	1.12	1.63	1.96	1.36	
10500	0.78	1.73	1.84	0.51	1.00	1.48	1.84	1.26	
10800	0.73	1.61	1.73	0.46	0.91	1.35	1.73	1.16	
Sections below exceed the normal delivery length of 12000mm									
11100	0.67	1.50	1.62	0.41	0.82	1.24	1.62	1.07	
11400	0.63	1.40	1.53		0.75	1.13	1.52	0.99	
11700	0.58	1.31	1.44		0.68	1.04	1.39	0.92	
12000	0.54	1.22	1.37		0.62	0.95	1.28	0.86	

Bold capacities require grade 8.8 purlin bolts.

Values above dotted horizontal line in body of table are governed by the strength of the grade 8.8 bolt.

INWARD = Inward load capacity. OUTWARD = Outward load capacity. L/150 = Load for deflection span/150.

See also: Design notes for capacity tables.

Three Lapped Spans

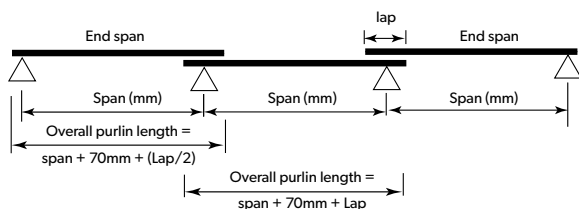

Bridging > Span mm	Z 25019/25024 (kN/m)								L/150	Z 25024 (kN/m)								L/150	
	INWARD				OUTWARD					L/150	INWARD				OUTWARD				
	0	1	2, 3		0	1	2	3			0	1	2, 3		0	1	2		3
3000	19.82	19.82	19.82		19.82	19.82	19.82	19.82	68.59	19.78	19.78	19.78		19.78	19.78	19.78	19.78	70.48	
3300	17.09	17.88	17.88		17.88	17.88	17.88	17.88	51.26	17.87	17.99	17.99		17.99	17.99	17.99	17.99	52.70	
3600	13.10	15.36	15.36		15.36	15.36	15.36	15.36	39.29	13.95	16.50	16.50		16.50	16.50	16.50	16.50	40.41	
3900	10.46	13.34	13.34		13.34	13.34	13.34	13.34	30.77	11.16	15.24	15.24		15.24	15.24	15.24	15.24	31.65	
4200	8.53	11.69	11.69		11.69	11.69	11.69	11.69	24.54	9.12	14.16	14.16		14.16	14.16	14.16	14.16	25.24	
4500	7.08	10.33	10.33		10.33	10.33	10.33	10.33	19.88	7.58	13.22	13.22		13.22	13.22	13.22	13.22	20.45	
4800	5.97	9.18	9.18		9.18	9.18	9.18	9.18	16.32	6.40	12.40	12.40		12.40	12.40	12.40	12.40	16.80	
5100	5.10	8.21	8.21		7.83	8.21	8.21	8.21	13.57	5.46	11.68	11.68		9.13	11.68	11.68	11.68	13.96	
5400	4.40	7.39	7.39		6.47	7.39	7.39	7.39	11.40	4.72	10.55	10.55		7.50	10.55	10.55	10.55	11.73	
5700	3.83	6.67	6.67		5.40	6.67	6.67	6.67	9.66	4.11	9.45	9.45		6.24	9.45	9.45	9.45	9.95	
6000	3.36	6.06	6.06	4.56	6.06	6.06	6.06	6.06	8.27	3.61	8.52	8.52		5.20	8.52	8.52	8.52	8.51	
6300	2.98	5.52	5.52	3.88	5.52	5.52	5.52	5.52	7.15	3.20	7.67	7.71	4.35	7.48	7.71	7.71	7.71	7.33	
6600	2.65	5.04	5.04	3.32	5.04	5.04	5.04	5.04	6.25	2.85	6.87	7.02	3.66	6.59	7.02	7.02	7.02	6.38	
6900	2.37	4.56	4.56	2.87	4.56	4.56	4.56	4.56	5.50	2.55	6.19	6.41	3.11	5.82	6.41	6.41	6.41	5.61	
7200	2.13	4.14	4.14	2.47	4.14	4.14	4.14	4.14	4.87	2.29	5.60	5.88	2.65	5.10	5.88	5.88	5.88	4.97	
7500	1.93	3.77	3.77	2.13	3.75	3.77	3.77	3.77	4.33	2.07	5.06	5.36	2.28	4.44	5.36	5.36	5.36	4.42	
7800	1.75	3.45	3.45	1.86	3.30	3.45	3.45	3.45	3.87	1.88	4.58	4.91	1.97	3.87	4.91	4.91	4.91	3.95	
8100	1.59	3.17	3.17	1.63	2.90	3.17	3.17	3.17	3.47	1.71	4.17	4.51	1.72	3.39	4.51	4.51	4.51	3.55	
8400	1.46	2.92	2.92	1.43	2.48	2.92	2.92	2.92	3.12	1.57	3.81	4.15	1.50	2.98	4.10	4.15	4.15	3.20	
8700	1.33	2.70	2.70	1.27	2.22	2.70	2.70	2.70	2.81	1.44	3.49	3.84	1.32	2.64	3.72	3.84	3.84	2.89	
9000	1.23	2.50	2.50	1.13	1.98	2.50	2.50	2.50	2.54	1.32	3.20	3.56	1.17	2.35	3.38	3.56	3.56	2.61	
9300	1.15	2.50	2.50	1.02	1.85	2.50	2.50	2.50	2.32	1.23	3.04	3.53	1.05	2.14	3.21	3.53	3.53	2.39	
9600	1.06	2.33	2.33	0.91	1.66	2.33	2.33	2.33	2.12	1.13	2.81	3.31	0.94	1.90	2.91	3.31	3.31	2.18	
9900	0.98	2.16	2.17	0.81	1.50	2.17	2.17	2.17	1.93	1.05	2.59	3.08	0.84	1.69	2.63	3.08	3.08	1.99	
10200	0.91	2.01	2.03	0.73	1.36	2.02	2.03	2.03	1.77	0.97	2.39	2.88	0.75	1.51	2.37	2.86	2.86	1.82	
10500	0.84	1.87	1.90	0.66	1.24	1.84	1.90	1.90	1.63	0.91	2.21	2.70	0.68	1.36	2.14	2.64	2.64	1.67	
10800	0.78	1.74	1.78	0.59	1.13	1.67	1.78	1.78	1.50	0.84	2.05	2.53	0.61	1.22	1.94	2.44	2.44	1.54	
Sections below exceed the normal delivery length of 12000mm																			
11100	0.73	1.62	1.68	0.54	1.02	1.52	1.68	1.68	1.39	0.79	1.91	2.38	0.55	1.10	1.76	2.25	2.25	1.42	
11400	0.68	1.51	1.58	0.49	0.93	1.34	1.58	1.58	1.28	0.73	1.78	2.25	0.50	1.00	1.61	2.09	2.09	1.31	
11700	0.63	1.41	1.49	0.45	0.85	1.23	1.49	1.49	1.19	0.69	1.66	2.12	0.46	0.90	1.47	1.94	1.94	1.21	
12000	0.59	1.32	1.41	0.41	0.77	1.14	1.41	1.41	1.10	0.64	1.56	2.00	0.42	0.82	1.34	1.79	1.79	1.13	

Bold capacities require grade 8.8 purlin bolts.

Values above dotted horizontal line in body of table are governed by the strength of the grade 8.8 bolt.

INWARD = Inward load capacity. OUTWARD = Outward load capacity. L/150 = Load for deflection span/150.

See also: Design notes for capacity tables.

Three Lapped Spans

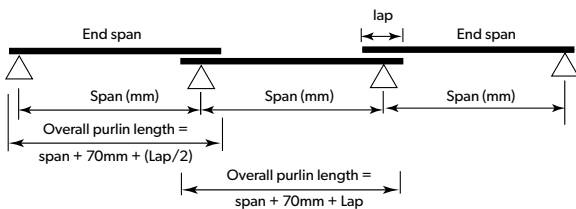

Bridging > Span mm	Z 30024 (kN/m)									Z 30024/30030 (kN/m)								
	INWARD				OUTWARD				L/150	INWARD			OUTWARD			L/150		
	0	1	2	3	0	1	2	3		0	1	2,3	0	1	2		3	
6000	5.36	10.31	10.31	10.31	10.12	10.31	10.31	10.31	14.12	5.96	11.20	11.20	11.20	11.20	11.20	11.20	18.35	
6300	4.70	9.50	9.50	9.50	8.59	9.50	9.50	9.50	12.17	5.20	10.24	10.24	10.24	10.24	10.24	10.24	15.81	
6600	4.15	8.77	8.77	8.77	7.29	8.77	8.77	8.77	10.56	4.58	9.40	9.40	8.82	9.40	9.40	9.40	13.73	
6900	3.69	8.12	8.12	8.12	6.35	8.12	8.12	8.12	9.22	4.06	8.65	8.65	7.58	8.65	8.65	8.65	11.99	
7200	3.30	7.54	7.54	7.54	5.57	7.54	7.54	7.54	8.10	3.62	7.99	7.99	6.47	7.99	7.99	7.99	10.53	
7500	2.97	7.01	7.01	7.01	4.88	7.01	7.01	7.01	7.16	3.25	7.40	7.40	5.68	7.40	7.40	7.40	9.38	
7800	2.68	6.53	6.53	6.53	4.25	6.53	6.53	6.53	6.35	2.93	6.87	6.87	5.01	6.87	6.87	6.87	8.39	
8100	2.43	6.10	6.10	6.10	3.73	6.10	6.10	6.10	5.73	2.66	6.38	6.38	4.45	6.38	6.38	6.38	7.55	
8400	2.21	5.66	5.71	5.71	3.28	5.62	5.71	5.71	5.20	2.42	5.88	5.88	3.97	5.88	5.88	5.88	6.81	
8700	2.03	5.16	5.28	5.28	2.88	5.06	5.28	5.28	4.73	2.21	5.44	5.44	3.53	5.44	5.44	5.44	6.17	
9000	1.86	4.73	4.89	4.89	2.53	4.57	4.89	4.89	4.31	2.02	5.04	5.04	3.14	5.04	5.04	5.04	5.61	
9300	1.72	4.51	4.85	4.85	2.29	4.22	4.85	4.85	3.95	1.88	4.89	5.04	2.89	4.94	5.04	5.04	5.15	
9600	1.59	4.14	4.54	4.54	2.04	3.79	4.54	4.54	3.60	1.73	4.50	4.69	2.57	4.49	4.69	4.69	4.70	
9900	1.47	3.80	4.24	4.24	1.81	3.35	4.24	4.24	3.29	1.60	4.15	4.37	2.29	4.09	4.37	4.37	4.30	
10200	1.37	3.50	3.96	3.96	1.62	3.04	3.96	3.96	3.02	1.49	3.84	4.08	2.06	3.70	4.08	4.08	3.94	
10500	1.27	3.24	3.71	3.71	1.46	2.77	3.71	3.71	2.77	1.38	3.55	3.82	1.85	3.35	3.82	3.82	3.62	
10800	1.19	3.00	3.48	3.48	1.31	2.53	3.48	3.48	2.55	1.29	3.28	3.59	1.67	3.05	3.59	3.59	3.34	
Sections below exceed the normal delivery length of 12000mm																		
11100	1.11	2.78	3.27	3.27	1.18	2.32	3.27	3.27	2.36	1.20	3.05	3.38	1.51	2.77	3.38	3.38	3.08	
11400	1.04	2.59	3.09	3.09	1.07	2.13	3.04	3.09	2.18	1.13	2.83	3.18	1.37	2.49	3.18	3.18	2.84	
11700	0.97	2.42	2.91	2.91	0.97	1.96	2.81	2.91	2.02	1.05	2.64	3.00	1.24	2.30	3.00	3.00	2.63	
12000	0.91	2.26	2.75	2.75	0.88	1.80	2.61	2.75	1.88	0.99	2.47	2.84	1.14	2.12	2.84	2.84	2.43	
12300	0.87	2.14	2.78	2.78	0.83	1.71	2.49	2.78	1.77	0.94	2.37	3.00	1.07	2.08	2.96	3.00	2.30	
12600	0.82	2.02	2.65	2.65	0.76	1.57	2.30	2.65	1.65	0.89	2.22	2.84	0.98	1.93	2.75	2.84	2.13	
12900	0.77	1.90	2.52	2.52	0.70	1.44	2.12	2.52	1.55	0.84	2.08	2.69	0.90	1.79	2.56	2.69	1.99	
13200	0.73	1.80	2.41	2.41	0.64	1.32	1.97	2.41	1.45	0.79	1.96	2.55	0.83	1.65	2.39	2.55	1.85	
13500	0.69	1.70	2.30	2.30	0.59	1.21	1.80	2.30	1.36	0.75	1.85	2.42	0.76	1.52	2.22	2.42	1.73	
13800	0.65	1.61	2.20	2.20	0.54	1.12	1.68	2.17	1.28	0.71	1.75	2.30	0.70	1.41	2.06	2.30	1.62	
14100	0.62	1.53	2.11	2.11	0.50	1.03	1.57	2.04	1.20	0.67	1.65	2.19	0.65	1.31	1.91	2.19	1.52	
14400	0.58	1.45	2.02	2.02	0.46	0.95	1.47	1.92	1.14	0.64	1.56	2.08	0.60	1.22	1.78	2.08	1.42	
14700	0.56	1.38	1.93	1.93	0.43	0.88	1.37	1.81	1.07	0.60	1.48	1.99	0.56	1.13	1.66	1.99	1.34	
15000	0.53	1.31	1.84	1.84	0.40	0.81	1.29	1.69	1.01	0.57	1.41	1.90	0.52	1.04	1.55	1.90	1.26	
15300	0.50	1.24	1.76	1.76	0.37	0.75	1.21	1.58	0.95	0.55	1.34	1.82	0.49	0.97	1.42	1.82	1.18	
15600	0.48	1.18	1.67	1.68	0.34	0.70	1.13	1.48	0.90	0.52	1.27	1.74	0.45	0.90	1.34	1.72	1.12	
15900	0.45	1.13	1.59	1.61	0.31	0.65	1.06	1.38	0.85	0.50	1.21	1.66	0.42	0.84	1.26	1.63	1.05	
16200	0.43	1.07	1.52	1.55	0.28	0.61	1.00	1.30	0.81	0.47	1.16	1.60	0.40	0.78	1.19	1.54	1.00	
16500	0.41	1.03	1.45	1.49	0.26	0.57	0.93	1.22	0.76	0.45	1.10	1.53	0.37	0.73	1.12	1.46	0.94	
16800	0.39	0.98	1.39	1.43	0.24	0.53	0.88	1.13	0.73	0.43	1.05	1.47	0.35	0.68	1.06	1.38	0.89	
17100	0.37	0.94	1.33	1.37	0.22	0.49	0.82	1.06	0.69	0.41	1.01	1.41	0.33	0.64	1.00	1.30	0.85	
17400	0.35	0.90	1.27	1.32	0.20	0.46	0.78	1.01	0.65	0.39	0.96	1.36	0.31	0.60	0.94	1.23	0.80	

Bold capacities require grade 8.8 purlin bolts.
 Values above dotted horizontal line in body of table are governed by the strength of the grade 8.8 bolt.
 INWARD = Inward load capacity. OUTWARD = Outward load capacity. L/150 = Load for deflection span/150.
 See also: Design notes for capacity tables.
 Note: In mixed spans, the thicker sections is used in the end span.

Three Lapped Spans

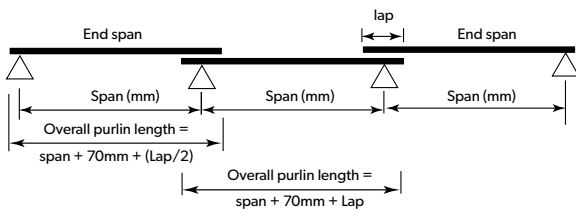

Bridging > Span mm	Z 30030 (kN/m)								L/150	Z 35030 (kN/m)								L/150
	INWARD				OUTWARD					INWARD				OUTWARD				
	0	1	2	3	0	1	2	3		0	1	2	3	0	1	2	3	
6000	6.31	16.68	16.68	16.68	14.28	16.68	16.68	16.68	18.83	9.78	17.56	17.56	17.56	17.56	17.56	17.56	17.56	29.23
6300	5.51	15.10	15.10	15.10	12.15	15.10	15.10	15.10	16.23	8.46	16.20	16.20	16.20	16.20	16.20	16.20	16.20	25.20
6600	4.85	13.69	13.74	13.74	10.39	13.74	13.74	13.74	14.09	7.36	14.99	14.99	14.99	14.99	14.99	14.99	14.99	21.87
6900	4.30	12.31	12.55	12.55	8.83	12.55	12.55	12.55	12.30	6.45	13.90	13.90	13.90	13.90	13.90	13.90	13.90	19.10
7200	3.83	11.12	11.51	11.51	7.56	11.51	11.51	11.51	10.81	5.69	12.92	12.92	12.92	12.92	12.89	12.92	12.92	16.78
7500	3.44	10.01	10.49	10.49	6.50	10.47	10.49	10.49	9.55	5.05	12.03	12.03	12.03	11.23	12.03	12.03	12.03	14.82
7800	3.10	9.05	9.60	9.60	5.62	9.41	9.60	9.60	8.53	4.51	11.23	11.23	11.23	9.82	11.23	11.23	11.23	13.15
8100	2.81	8.21	8.82	8.82	4.89	8.49	8.82	8.82	7.66	4.06	10.50	10.50	10.50	8.64	10.50	10.50	10.50	11.73
8400	2.55	7.48	8.13	8.13	4.27	7.68	8.13	8.13	6.92	3.66	9.83	9.83	9.83	7.62	9.83	9.83	9.83	10.50
8700	2.33	6.84	7.52	7.52	3.75	6.97	7.52	7.52	6.27	3.32	9.21	9.21	9.21	6.76	9.21	9.21	9.21	9.44
9000	2.14	6.28	6.98	6.98	3.31	6.34	6.98	6.98	5.70	3.02	8.54	8.54	8.54	5.89	8.54	8.54	8.54	8.51
9300	1.98	5.97	6.91	6.91	3.00	6.00	6.91	6.91	5.23	2.78	8.27	8.46	8.46	5.50	8.46	8.46	8.46	7.80
9600	1.83	5.47	6.48	6.48	2.67	5.40	6.48	6.48	4.79	2.55	7.62	7.93	7.93	4.98	7.93	7.93	7.93	7.15
9900	1.69	5.02	6.04	6.04	2.38	4.87	6.04	6.04	4.40	2.35	7.00	7.39	7.39	4.51	7.39	7.39	7.39	6.60
10200	1.57	4.61	5.64	5.64	2.13	4.40	5.63	5.64	4.03	2.17	6.45	6.91	6.91	4.09	6.91	6.91	6.91	6.08
10500	1.46	4.26	5.29	5.29	1.91	3.97	5.20	5.29	3.70	2.01	5.92	6.47	6.47	3.72	6.39	6.47	6.47	5.59
10800	1.36	3.94	4.96	4.96	1.73	3.58	4.82	4.96	3.41	1.86	5.46	6.08	6.08	3.36	5.88	6.08	6.08	5.15
Sections below exceed the normal delivery length of 12000mm																		
11100	1.27	3.66	4.67	4.67	1.56	3.23	4.47	4.67	3.15	1.74	5.04	5.71	5.71	3.05	5.42	5.71	5.71	4.76
11400	1.19	3.40	4.40	4.40	1.41	2.93	4.16	4.40	2.92	1.62	4.66	5.38	5.38	2.78	4.98	5.38	5.38	4.41
11700	1.12	3.16	4.15	4.15	1.29	2.66	3.87	4.15	2.70	1.51	4.33	5.08	5.08	2.53	4.57	5.08	5.08	4.09
12000	1.05	2.94	3.92	3.92	1.17	2.42	3.61	3.92	2.50	1.42	4.02	4.80	4.80	2.32	4.19	4.80	4.80	3.80
12300	1.00	2.80	3.88	3.97	1.10	2.27	3.52	3.97	2.36	1.34	3.86	4.85	4.85	2.20	4.00	4.85	4.85	3.58
12600	0.94	2.62	3.67	3.78	1.01	2.08	3.28	3.76	2.19	1.26	3.61	4.62	4.62	2.01	3.69	4.62	4.62	3.33
12900	0.89	2.45	3.47	3.60	0.93	1.90	3.03	3.54	2.04	1.19	3.38	4.41	4.41	1.84	3.41	4.41	4.41	3.11
13200	0.84	2.30	3.29	3.44	0.85	1.75	2.81	3.33	1.91	1.12	3.17	4.20	4.20	1.68	3.15	4.20	4.20	2.91
13500	0.80	2.16	3.12	3.28	0.78	1.61	2.61	3.15	1.78	1.06	2.97	4.02	4.02	1.55	2.92	4.02	4.02	2.73
13800	0.76	2.04	2.96	3.14	0.72	1.48	2.43	2.97	1.66	1.00	2.80	3.84	3.84	1.43	2.65	3.84	3.84	2.56
14100	0.72	1.92	2.81	3.00	0.67	1.36	2.25	2.81	1.56	0.95	2.57	3.68	3.68	1.32	2.48	3.63	3.68	2.40
14400	0.68	1.81	2.68	2.88	0.62	1.26	2.08	2.66	1.46	0.90	2.44	3.52	3.52	1.22	2.32	3.42	3.52	2.26
14700	0.65	1.71	2.54	2.75	0.58	1.17	1.93	2.50	1.37	0.86	2.30	3.36	3.36	1.13	2.17	3.21	3.36	2.13
15000	0.62	1.62	2.42	2.62	0.54	1.08	1.79	2.37	1.29	0.82	2.18	3.21	3.21	1.04	2.03	3.02	3.21	2.01
15300	0.59	1.53	2.30	2.51	0.50	1.00	1.66	2.23	1.22	0.78	2.07	3.07	3.07	0.97	1.90	2.84	3.07	1.90
15600	0.56	1.46	2.19	2.39	0.47	0.93	1.55	2.10	1.15	0.74	1.96	2.94	2.94	0.90	1.79	2.66	2.94	1.79
15900	0.53	1.38	2.09	2.28	0.44	0.87	1.44	1.97	1.08	0.71	1.87	2.82	2.82	0.84	1.68	2.49	2.82	1.69
16200	0.51	1.31	1.99	2.17	0.41	0.81	1.34	1.85	1.02	0.67	1.78	2.70	2.70	0.78	1.58	2.34	2.70	1.61
16500	0.49	1.25	1.90	2.08	0.40	0.76	1.25	1.74	0.97	0.64	1.69	2.57	2.59	0.73	1.49	2.20	2.59	1.53
16800	0.47	1.19	1.82	1.99	0.40	0.71	1.17	1.64	0.92	0.62	1.61	2.45	2.49	0.69	1.39	2.07	2.49	1.45
17100	0.45	1.13	1.74	1.90	0.40	0.66	1.10	1.54	0.87	0.59	1.54	2.34	2.39	0.64	1.31	1.95	2.39	1.38
17400	0.43	1.08	1.66	1.82	0.40	0.62	1.03	1.46	0.82	0.57	1.47	2.23	2.30	0.60	1.23	1.83	2.30	1.31

Bold capacities require grade 8.8 purlin bolts.
 Values above dotted horizontal line in body of table are governed by the strength of the grade 8.8 bolt.
 INWARD = Inward load capacity. OUTWARD = Outward load capacity. L/150 = Load for deflection span/150.
 See also: Design notes for capacity tables.

Three Lapped Spans

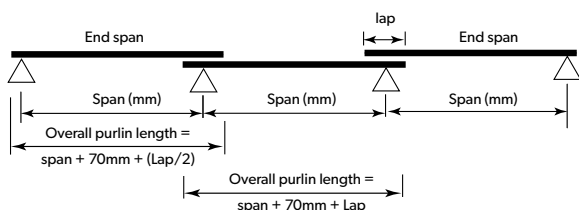

FOUR CONTINUOUS SPANS

Span mm	Z/C 10010 (kN/m)				Z/C 10012 (kN/m)				Z/C 10015 (kN/m)				Z/C 10019 (kN/m)			
	INWARD		OUTWARD		INWARD		OUTWARD		INWARD		OUTWARD		INWARD		OUTWARD	
	0, 1, 2, 3	0	1, 2, 3	L/150	0, 1, 2, 3	0	1, 2, 3	L/150	0, 1, 2, 3	0	1, 2, 3	L/150	0, 1, 2, 3	0	1, 2, 3	L/150
2100	4.64	4.64	4.64	6.78	5.64	5.64	5.64	8.36	7.35	7.35	7.35	10.94	10.26	10.26	10.26	14.51
2400	3.55	3.52	3.55	4.57	4.32	4.20	4.32	5.60	5.63	5.63	5.63	7.33	7.85	7.85	7.85	9.72
2700	2.80	2.30	2.80	3.26	3.41	2.84	3.41	3.98	4.45	3.93	4.45	5.16	6.20	5.34	6.20	6.87
3000	2.27	1.55	2.27	2.40	2.77	2.00	2.77	2.93	3.60	2.67	3.60	3.82	5.03	3.57	5.03	5.02

Sections below exceed the normal delivery length of 12000mm

3300	1.88	1.13	1.88	1.83	2.29	1.40	2.29	2.23	2.98	1.87	2.98	2.92	4.15	2.49	4.15	3.79
3600	1.58	0.83	1.58	1.42	1.92	1.02	1.92	1.73	2.50	1.34	2.50	2.28	3.49	1.80	3.49	2.94
3900	1.34	0.62	1.34	1.13	1.64	0.75	1.64	1.38	2.13	0.99	2.13	1.82	2.97	1.33	2.97	2.33

Span mm	Z/C 15012 (kN/m)				Z/C 15015 (kN/m)				Z/C 15019 (kN/m)				Z/C 15024 (kN/m)			
	INWARD		OUTWARD		INWARD		OUTWARD		INWARD		OUTWARD		INWARD		OUTWARD	
	0, 1, 2, 3	0	1, 2, 3	L/150	0, 1, 2, 3	0	1, 2, 3	L/150	0, 1, 2, 3	0	1, 2, 3	L/150	0, 1, 2, 3	0	1, 2, 3	L/150
2100	6.92	6.92	6.92	23.18	11.36	11.36	11.36	31.49	17.10	17.10	17.10	41.09	21.60	21.60	21.60	54.80
2400	5.77	5.77	5.77	15.53	9.22	9.22	9.22	21.10	13.66	13.66	13.66	27.53	18.90	18.90	18.90	36.71
2700	4.88	4.88	4.88	10.90	7.62	7.62	7.62	14.82	11.04	11.04	11.04	19.33	15.59	15.59	15.59	25.78
3000	4.18	4.18	4.18	7.95	6.36	6.36	6.36	10.80	8.96	8.96	8.96	14.09	12.62	12.62	12.62	18.80

Sections below exceed the normal delivery length of 12000mm

3300	3.61	3.61	3.61	5.97	5.25	5.02	5.25	8.12	7.41	6.97	7.41	10.59	10.43	9.47	10.43	14.12
3600	3.15	2.76	3.15	4.60	4.41	3.76	4.41	6.25	6.22	5.10	6.22	8.16	8.77	6.80	8.77	10.88
3900	2.77	2.04	2.77	3.64	3.76	2.82	3.76	4.92	5.30	3.74	5.30	6.42	7.47	5.00	7.47	8.56

Span mm	Z/C 20015 (kN/m)				Z/C 20019 (kN/m)				Z/C 20024 (kN/m)			
	INWARD		OUTWARD		INWARD		OUTWARD		INWARD		OUTWARD	
	0, 1, 2, 3	0	1, 2, 3	L/150	0, 1, 2, 3	0	1, 2, 3	L/150	0, 1, 2, 3	0	1, 2, 3	L/150
2100	10.57	10.57	10.57	62.26	17.10	17.10	17.10	88.71	21.60	21.60	21.60	117.14
2400	8.92	8.92	8.92	41.71	14.96	14.96	14.96	59.43	18.90	18.90	18.90	78.47
2700	7.64	7.64	7.64	29.29	13.30	13.30	13.30	41.74	16.80	16.80	16.80	55.11
3000	6.62	6.62	6.62	21.35	11.81	11.81	11.81	30.43	15.12	15.12	15.12	40.18
3300	5.78	5.78	5.78	16.04	10.18	10.18	10.18	22.86	13.75	13.75	13.75	30.19

Sections below exceed the normal delivery length of 12000mm

3600	5.09	5.09	5.09	12.36	8.85	8.85	8.85	17.61	12.60	12.60	12.60	23.25
3900	4.52	4.52	4.52	9.72	7.76	7.70	7.76	13.85	11.29	11.10	11.29	18.29

Bold capacities require grade 8.8 purlin bolts.

Values above dotted horizontal line in body of table are governed by the strength of the grade 8.8 bolt.

INWARD = Inward load capacity. OUTWARD = Outward load capacity. L/150 = Load for deflection span/150.

See also: Design notes for capacity tables.

Four Continuous Spans

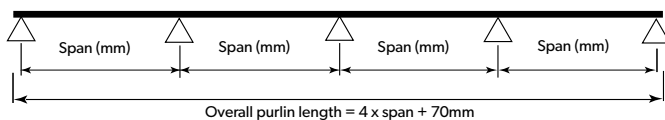

Bridging > Span mm	Z 10010 (kN/m)							Z 10010/10015 (kN/m)						Z 10012 (kN/m)									
	INWARD			OUTWARD				L/150	INWARD			OUTWARD			L/150	INWARD			OUTWARD			L/150	
	0	1, 2, 3		0	1	2	3		0	1, 2, 3	0	1	2, 3	0		1, 2, 3	0	1	2	3			
2100	7.03	7.03		7.03	7.03	7.03	7.03	7.81	8.33	8.33		8.33	8.33	8.33	12.07	8.04	8.56		8.56	8.56	8.56	8.56	9.62
2400	5.22	5.34		5.34	5.34	5.34	5.34	5.17	5.96	6.30		6.30	6.30	6.30	7.98	5.92	6.50		6.50	6.50	6.50	6.50	6.37
2700	3.98	4.19		4.19	4.19	4.19	4.19	3.60	4.39	4.76		4.76	4.76	4.76	5.55	4.50	5.10		4.96	5.10	5.10	5.10	4.43
3000	3.10	3.37		3.04	3.37	3.37	3.37	2.61	3.35	3.64		3.64	3.64	3.64	4.01	3.51	4.11		3.67	4.11	4.11	4.11	3.20
3300	2.46	2.73		2.20	2.73	2.73	2.73	1.98	2.63	2.87		2.82	2.87	2.87	3.03	2.79	3.32		2.67	3.32	3.32	3.32	2.41
3600	1.98	2.21		1.63	2.21	2.21	2.21	1.53	2.12	2.32		2.14	2.32	2.32	2.35	2.24	2.69		1.91	2.69	2.69	2.69	1.87
3900	1.61	1.83		1.23	1.83	1.83	1.83	1.21	1.73	1.92		1.64	1.92	1.92	1.87	1.84	2.23		1.47	2.23	2.23	2.23	1.48
4200	1.34	1.54		0.95	1.54	1.54	1.54	0.97	1.43	1.61		1.28	1.61	1.61	1.51	1.53	1.87		1.15	1.85	1.87	1.87	1.19
4500	1.12	1.31		0.75	1.27	1.31	1.31	0.79	1.20	1.38		1.02	1.38	1.38	1.23	1.28	1.60		0.92	1.51	1.60	1.60	0.97
4800	0.95	1.13		0.58	1.03	1.13	1.13	0.66	1.02	1.19		0.82	1.19	1.19	1.01	1.09	1.38		0.75	1.24	1.38	1.38	0.80
5100	0.81	0.99		0.48	0.83	0.99	0.99	0.55	0.87	1.03		0.67	1.03	1.03	0.84	0.89	1.20		0.62	1.02	1.20	1.20	0.68
5400	0.70	0.87		0.40	0.69	0.87	0.87	0.47	0.74	0.91		0.56	0.90	0.91	0.71	0.77	1.06		0.50	0.84	1.06	1.06	0.57
5700	0.60	0.77			0.57	0.77	0.77	0.40	0.64	0.81		0.47	0.76	0.81	0.60	0.67	0.94		0.42	0.67	0.94	0.94	0.49
6000	0.52	0.69			0.48	0.68	0.69	0.34	0.56	0.72		0.64	0.72	0.72	0.52	0.59	0.84			0.57	0.81	0.84	0.42
6300	0.48	0.68			0.42	0.62	0.68	0.30	0.51	0.72		0.58	0.72	0.72	0.46	0.54	0.83			0.51	0.75	0.83	0.37
6600	0.42	0.62				0.53	0.62	0.26	0.45	0.64		0.49	0.64	0.64	0.40	0.48	0.75			0.44	0.64	0.75	0.33
6900		0.56				0.45	0.56	0.23	0.40	0.58		0.42	0.58	0.58	0.35	0.43	0.68				0.55	0.67	0.29

Bridging > Span mm	Z 10012/10019 (kN/m)						Z 10015 (kN/m)						Z 10019 (kN/m)										
	INWARD			OUTWARD			L/150	INWARD			OUTWARD			L/150	INWARD			OUTWARD			L/150		
	0	1, 2, 3		0	1	2, 3		0	1	2	3	0	1		2	3	0	1	2, 3	0		1	2
2100	9.92	11.41		11.41	11.41	11.41	15.94	9.64	11.16	11.16	11.16	11.16	11.16	12.59	12.64	15.57	15.57		15.57	15.57	15.57	15.57	16.70
2400	6.91	7.97		7.97	7.97	7.97	10.54	7.12	8.47	8.47	8.47	8.47	8.47	8.34	9.10	11.82	11.82		11.71	11.82	11.82	11.82	11.06
2700	5.08	5.83		5.83	5.83	5.83	7.32	5.43	6.65	6.65	6.65	6.65	6.65	5.80	6.83	9.27	9.27		8.61	9.27	9.27	9.27	7.69
3000	3.88	4.45		4.45	4.45	4.45	5.31	4.25	5.35	5.35	5.35	5.35	5.35	4.19	5.31	7.47	7.47		6.41	7.47	7.47	7.47	5.56
3300	3.05	3.51		3.46	3.51	3.51	3.97	3.39	4.33	4.33	4.33	4.33	4.33	3.13	4.22	6.04	6.04		4.83	6.04	6.04	6.04	4.17
3600	2.45	2.85		2.68	2.85	2.85	3.05	2.73	3.51	3.51	3.51	3.51	3.51	2.43	3.40	4.90	4.90		3.60	4.90	4.90	4.90	3.20
3900	2.00	2.35		2.11	2.35	2.35	2.40	2.25	2.90	2.90	2.90	2.90	2.90	1.93	2.80	4.05	4.05		2.77	3.99	4.05	4.05	2.51
4200	1.66	1.98		1.67	1.98	1.98	1.92	1.88	2.44	2.44	2.44	2.44	2.44	1.56	2.34	3.41	3.41		2.15	3.25	3.41	3.41	2.01
4500	1.40	1.69		1.34	1.69	1.69	1.56	1.59	2.08	2.08	2.08	2.08	2.08	1.28	1.98	2.91	2.91		1.69	2.66	2.91	2.91	1.64
4800	1.19	1.45		1.05	1.45	1.45	1.28	1.35	1.80	1.80	1.80	1.80	1.80	1.06	1.70	2.51	2.51		1.36	2.20	2.51	2.51	1.36
5100	1.01	1.27		0.87	1.27	1.27	1.07	1.17	1.57	1.57	1.57	1.57	1.57	0.88	1.46	2.19	2.19		1.10	1.84	2.19	2.19	1.13
5400	0.87	1.11		0.73	1.11	1.11	0.90	1.01	1.38	1.38	1.38	1.38	1.38	0.74	1.27	1.92	1.92		0.91	1.55	1.90	1.92	0.95
5700	0.73	0.99		0.62	0.95	0.99	0.76	0.89	1.22	1.22	1.22	1.22	1.22	0.63	1.11	1.71	1.71		0.76	1.30	1.65	1.71	0.80
6000	0.64	0.88		0.54	0.82	0.88	0.65	0.78	1.09	1.09	1.09	1.09	1.09	0.54	0.98	1.52	1.52		0.64	1.10	1.43	1.52	0.69
6300	0.59	0.88		0.49	0.76	0.88	0.57	0.71	1.06	1.09	1.09	1.09	1.09	0.48	0.89	1.48	1.51		0.56	0.98	1.33	1.51	0.61
6600	0.52	0.79		0.43	0.65	0.79	0.50	0.63	0.95	0.98	0.98	0.98	0.98	0.42	0.79	1.32	1.36		0.48	0.83	1.16	1.34	0.53
6900	0.47	0.71			0.56	0.71	0.44	0.56	0.85	0.88	0.88	0.88	0.88	0.36	0.71	1.18	1.23		0.42	0.71	1.01	1.18	0.46
7200	0.41	0.65			0.47	0.64	0.38	0.50	0.77	0.80	0.80	0.80	0.80	0.32	0.63	1.06	1.12			0.61	0.89	1.05	0.40
7500		0.59			0.41	0.57	0.34	0.44	0.69	0.73	0.73	0.73	0.73	0.28	0.57	0.96	1.02			0.53	0.77	0.93	0.35
7800		0.54				0.51	0.30	0.40	0.63	0.67	0.67	0.67	0.67	0.25	0.51	0.87	0.93			0.46	0.68	0.83	0.31

Bold capacities require grade 8.8 purlin bolts.

Values above dotted horizontal line in body of table are governed by the strength of the grade 8.8 bolt.

INWARD = Inward load capacity. OUTWARD = Outward load capacity. L/150 = Load for deflection span/150.

See also: Design notes for capacity tables.

Note: In mixed spans, the thicker sections is used in the end span.

Four Lapped Spans

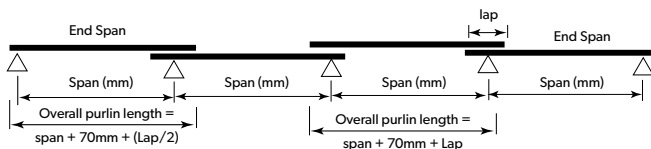

Bridging > Span mm	Z 15012 (kN/m)						Z 15012/15019 (kN/m)						Z 15015 (kN/m)											
	INWARD			OUTWARD			L/150	INWARD			OUTWARD			L/150	INWARD			OUTWARD			L/150			
	0	1, 2, 3		0	1	2		3	0	1, 2, 3		0	1		2	3	0	1	2, 3	0		1	2	3
3000	6.32	6.75		6.75	6.75	6.75	6.75	9.19	7.40	7.40		7.40	7.40	7.40	7.40	15.54	7.30	9.68	9.68	9.68	9.68	9.68	9.68	12.49
3300	5.00	5.71		5.71	5.71	5.71	5.71	6.85	5.82	6.17		6.17	6.17	6.17	6.17	11.57	5.81	7.95	7.95	7.95	7.95	7.95	7.95	9.31
3600	4.05	4.88		4.88	4.88	4.88	4.88	5.24	4.62	5.21		5.21	5.21	5.21	5.21	8.83	4.72	6.64	6.64	6.64	6.64	6.64	6.64	7.12
3900	3.35	4.21		3.90	4.21	4.21	4.21	4.09	3.75	4.45		4.45	4.45	4.45	4.45	6.89	3.91	5.63	5.63	5.63	5.63	5.63	5.63	5.56
4200	2.80	3.66		3.04	3.66	3.66	3.66	3.26	3.10	3.84		3.84	3.84	3.84	3.84	5.48	3.29	4.84	4.84	4.84	4.84	4.84	4.84	4.42
4500	2.37	3.19		2.40	3.19	3.19	3.19	2.63	2.60	3.34		3.30	3.34	3.34	3.34	4.43	2.80	4.20	4.20	4.20	4.20	4.20	4.20	3.58
4800	2.03	2.79		1.92	2.79	2.79	2.79	2.16	2.21	2.93		2.65	2.93	2.93	2.93	3.68	2.40	3.66	3.66	3.66	3.66	3.66	3.66	2.93
5100	1.75	2.40		1.55	2.40	2.40	2.40	1.83	1.89	2.54		2.16	2.54	2.54	2.54	3.08	2.07	3.16	3.16	3.16	3.16	3.16	3.16	2.44
5400	1.51	2.10		1.27	2.10	2.10	2.10	1.57	1.64	2.22		1.78	2.22	2.22	2.22	2.62	1.80	2.75	2.75	2.75	2.75	2.75	2.75	2.06
5700	1.32	1.84		1.05	1.80	1.84	1.84	1.35	1.43	1.95		1.48	1.95	1.95	1.95	2.24	1.57	2.42	2.42	2.42	2.42	2.42	2.42	1.76
6000	1.16	1.63		0.86	1.53	1.63	1.63	1.17	1.26	1.72		1.24	1.72	1.72	1.72	1.93	1.39	2.15	2.15	2.15	2.15	2.15	2.15	1.51
6300	1.02	1.46		0.73	1.29	1.46	1.46	1.02	1.11	1.54		1.06	1.54	1.54	1.54	1.67	1.23	1.92	1.92	1.92	1.92	1.92	1.92	1.31
6600	0.91	1.31		0.63	1.10	1.31	1.31	0.89	0.99	1.38		0.90	1.38	1.38	1.38	1.45	1.10	1.72	1.72	1.72	1.72	1.72	1.72	1.14
6900	0.81	1.18		0.54	0.94	1.18	1.18	0.78	0.88	1.25		0.78	1.25	1.25	1.25	1.27	0.98	1.55	1.55	1.55	1.55	1.55	1.55	1.00
7200	0.73	1.07		0.47	0.81	1.07	1.07	0.69	0.79	1.13		0.68	1.11	1.13	1.13	1.12	0.88	1.41	1.41	1.41	1.41	1.41	1.41	0.89
7500	0.65	0.98		0.41	0.70	0.98	0.98	0.61	0.71	1.03		0.59	0.99	1.03	1.03	0.99	0.80	1.29	1.29	1.29	1.29	1.29	1.29	0.79
7800	0.59	0.90			0.61	0.88	0.90	0.54	0.64	0.94		0.52	0.86	0.94	0.94	0.88	0.72	1.18	1.18	1.18	1.18	1.18	1.18	0.71
8100	0.53	0.82			0.54	0.79	0.82	0.49	0.58	0.87		0.45	0.76	0.87	0.87	0.79	0.66	1.08	1.08	1.08	1.08	1.08	1.08	0.63
8400	0.48	0.76			0.47	0.70	0.76	0.44	0.52	0.80		0.40	0.67	0.80	0.80	0.71	0.60	1.00	1.00	1.00	1.00	1.00	1.00	0.57
8700	0.44	0.70			0.42	0.62	0.70	0.40	0.48	0.74			0.60	0.74	0.74	0.64	0.55	0.92	0.92	0.92	0.92	0.92	0.92	0.52
9000	0.40	0.65			0.55	0.65	0.65	0.36	0.43	0.69			0.54	0.69	0.69	0.57	0.50	0.86	0.86	0.86	0.86	0.86	0.86	0.47
9300		0.65			0.51	0.65	0.65	0.33	0.41	0.68			0.50	0.68	0.68	0.53	0.47	0.84	0.85	0.85	0.85	0.85	0.85	0.43
9600		0.60			0.45	0.59	0.59	0.30		0.64			0.45	0.63	0.64	0.48	0.43	0.78	0.79	0.79	0.79	0.79	0.79	0.39
9900		0.56			0.41	0.54	0.54	0.27		0.59			0.40	0.58	0.59	0.44	0.40	0.72	0.74	0.74	0.74	0.74	0.74	0.36

Bold capacities require grade 8.8 purlin bolts.

Values above dotted horizontal line in body of table are governed by the strength of the grade 8.8 bolt.

INWARD = Inward load capacity. OUTWARD = Outward load capacity. L/150 = Load for deflection span/150.

See also: Design notes for capacity tables.

Note: In mixed spans, the thicker sections is used in the end span.

Four Lapped Spans

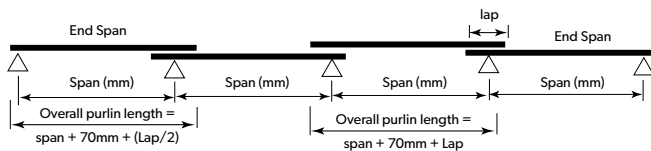

Bridging > Span mm	Z 15015/15024 (kN/m)					L/150	Z 15019 (kN/m)					L/150	Z 15024 (kN/m)					L/150							
	INWARD			OUTWARD			INWARD				OUTWARD		INWARD				OUTWARD								
	0	1	2, 3	0	1 2 3		0	1	2	3	0		1	2	3	0	1		2	3	0	1	2	3	
3000	9.17	12.11	12.11	12.11	12.11	20.75	9.42	13.64	13.64	13.64	13.56	13.64	13.64	13.64	16.29	11.57	18.71	18.71	18.71	18.71	18.71	18.71	18.71	21.73	
3300	7.02	9.79	9.79	9.79	9.79	15.44	7.39	11.21	11.21	11.21	10.61	11.21	11.21	11.21	12.14	8.97	15.79	15.79	15.79	15.79	14.89	15.79	15.79	15.79	16.20
3600	5.55	8.05	8.05	8.05	8.05	11.79	5.95	9.37	9.37	9.37	8.43	9.37	9.37	9.37	9.29	7.15	13.20	13.20	13.20	13.20	11.71	13.20	13.20	13.20	12.38
3900	4.49	6.59	6.59	6.59	6.59	9.20	4.89	7.94	7.94	7.94	6.77	7.94	7.94	7.94	7.25	5.82	11.19	11.19	11.19	11.19	9.33	11.19	11.19	11.19	9.67
4200	3.71	5.43	5.43	5.28	5.43	7.32	4.09	6.82	6.82	6.82	5.39	6.82	6.82	6.82	5.77	4.83	9.61	9.61	9.61	9.61	7.38	9.61	9.61	9.61	7.70
4500	3.11	4.56	4.56	4.28	4.56	5.93	3.47	5.92	5.92	5.92	4.29	5.92	5.92	5.92	4.67	4.06	8.34	8.34	8.34	8.34	5.78	8.34	8.34	8.34	6.22
4800	2.64	3.88	3.88	3.51	3.88	4.88	2.96	5.16	5.16	5.16	3.43	5.02	5.16	5.16	3.82	3.46	7.27	7.27	7.27	7.27	4.59	7.13	7.27	7.27	5.10
5100	2.27	3.34	3.34	2.88	3.34	4.07	2.54	4.45	4.45	4.45	2.78	4.22	4.45	4.45	3.20	2.98	6.23	6.27	6.27	6.27	3.69	5.96	6.27	6.27	4.25
5400	1.97	2.91	2.91	2.38	2.91	3.43	2.21	3.88	3.88	3.88	2.29	3.59	3.88	3.88	2.71	2.59	5.37	5.47	5.47	5.47	3.01	5.04	5.47	5.47	3.58
5700	1.72	2.56	2.56	1.94	2.56	2.93	1.93	3.40	3.41	3.41	1.88	3.07	3.41	3.41	2.32	2.26	4.68	4.81	4.81	4.81	2.48	4.29	4.81	4.81	3.05
6000	1.51	2.27	2.27	1.65	2.27	2.50	1.70	2.99	3.03	3.03	1.56	2.64	3.03	3.03	2.01	2.00	4.11	4.26	4.26	4.26	2.07	3.68	4.26	4.26	2.63
6300	1.34	2.02	2.02	1.42	2.02	2.16	1.51	2.65	2.70	2.70	1.31	2.29	2.70	2.70	1.74	1.77	3.63	3.80	3.80	3.80	1.74	3.18	3.80	3.80	2.28
6600	1.20	1.82	1.82	1.23	1.82	1.87	1.34	2.37	2.43	2.43	1.10	1.97	2.39	2.43	1.53	1.58	3.23	3.42	3.42	3.42	1.48	2.75	3.40	3.42	1.97
6900	1.07	1.64	1.64	1.07	1.64	1.63	1.20	2.12	2.19	2.19	0.94	1.71	2.11	2.19	1.34	1.42	2.89	3.09	3.09	3.09	1.26	2.37	3.00	3.09	1.72
7200	0.96	1.49	1.49	0.94	1.45	1.49	1.43	1.08	1.92	1.99	0.81	1.48	1.88	1.99	1.18	1.28	2.60	2.80	2.80	2.80	1.09	2.03	2.66	2.80	1.51
7500	0.87	1.36	1.36	0.83	1.29	1.36	1.26	0.98	1.74	1.81	0.70	1.28	1.68	1.81	1.04	1.16	2.35	2.55	2.55	2.55	0.95	1.76	2.37	2.55	1.33
7800	0.79	1.24	1.24	0.74	1.15	1.24	1.12	0.88	1.58	1.66	0.61	1.12	1.51	1.66	0.93	1.05	2.14	2.34	2.34	2.34	0.83	1.53	2.11	2.34	1.18
8100	0.72	1.14	1.14	0.66	1.03	1.14	1.00	0.80	1.44	1.52	0.53	0.98	1.36	1.52	0.83	0.96	1.95	2.15	2.15	2.15	0.73	1.33	1.90	2.15	1.05
8400	0.65	1.05	1.05	0.58	0.91	1.05	0.89	0.73	1.32	1.41	0.47	0.87	1.22	1.38	0.74	0.88	1.78	1.98	1.98	1.98	0.64	1.17	1.71	1.97	0.94
8700	0.60	0.97	0.97	0.52	0.82	0.97	0.80	0.67	1.21	1.30	0.41	0.77	1.11	1.26	0.67	0.81	1.63	1.83	1.83	1.83	0.57	1.03	1.54	1.79	0.85
9000	0.55	0.90	0.90	0.47	0.73	0.90	0.72	0.61	1.12	1.21	0.36	0.68	0.99	1.15	0.61	0.74	1.50	1.70	1.70	1.70	0.51	0.92	1.39	1.63	0.76
9300	0.52	0.90	0.90	0.44	0.67	0.90	0.67	0.57	1.08	1.18	0.34	0.62	0.93	1.11	0.56	0.70	1.45	1.64	1.69	1.69	0.47	0.83	1.29	1.56	0.70
9600	0.48	0.84	0.84	0.40	0.60	0.84	0.61	0.53	1.00	1.09	0.31	0.55	0.83	1.01	0.51	0.64	1.34	1.51	1.58	1.58	0.42	0.74	1.15	1.42	0.64
9900	0.44	0.78	0.78	0.35	0.55	0.78	0.55	0.48	0.93	1.01	0.28	0.49	0.75	0.93	0.46	0.60	1.24	1.40	1.47	1.47	0.37	0.67	1.03	1.30	0.58
10200	0.40	0.73	0.73	0.30	0.50	0.73	0.50	0.45	0.86	0.94	0.26	0.44	0.67	0.85	0.42	0.55	1.15	1.30	1.37	1.37	0.33	0.60	0.92	1.19	0.53
10500	0.36	0.68	0.68	0.26	0.46	0.68	0.46	0.41	0.80	0.87	0.23	0.40	0.61	0.78	0.39	0.51	1.07	1.20	1.29	1.29	0.30	0.54	0.83	1.09	0.48
10800	0.33	0.64	0.64	0.22	0.42	0.64	0.42	0.37	0.75	0.81	0.20	0.37	0.55	0.72	0.35	0.48	1.00	1.12	1.21	1.21	0.28	0.49	0.75	1.01	0.44
Sections below exceed the normal delivery length of 12000mm																									
11100	0.30	0.60	0.60	0.18	0.30	0.60	0.39	0.33	0.70	0.76	0.20	0.33	0.50	0.66	0.33	0.45	0.93	1.04	1.14	1.14	0.25	0.44	0.68	0.92	0.41
11400	0.27	0.56	0.57	0.15	0.27	0.57	0.36	0.30	0.65	0.71	0.18	0.30	0.46	0.61	0.30	0.42	0.87	0.97	1.07	1.07	0.22	0.40	0.62	0.85	0.38
11700	0.24	0.53	0.54	0.12	0.24	0.54	0.33	0.27	0.61	0.66	0.15	0.27	0.42	0.56	0.28	0.39	0.81	0.91	1.01	1.01	0.19	0.37	0.57	0.78	0.35

Bold capacities require grade 8.8 purlin bolts.

Values above dotted horizontal line in body of table are governed by the strength of the grade 8.8 bolt.

INWARD = Inward load capacity. OUTWARD = Outward load capacity. L/150 = Load for deflection span/150.

See also: Design notes for capacity tables.

Four Lapped Spans

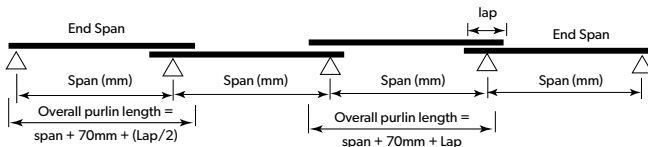

Bridging > Span mm	Z 20015 (kN/m)							Z 20015/20024 (kN/m)							
	INWARD			OUTWARD				L/150	INWARD			OUTWARD			L/150
	0	1, 2, 3		0	1	2	3		0	1, 2, 3		0	1	2, 3	
3000	10.05	10.05		10.05	10.05	10.05	10.05	24.69	11.35	11.35		11.35	11.35	11.35	44.18
3300	8.62	8.62		8.62	8.62	8.62	8.62	18.40	9.60	9.60		9.60	9.60	9.60	32.87
3600	6.93	7.47		7.47	7.47	7.47	7.47	14.07	8.16	8.22		8.22	8.22	8.22	25.09
3900	5.67	6.53		6.53	6.53	6.53	6.53	10.99	6.55	7.11		7.11	7.11	7.11	19.58
4200	4.72	5.74		5.74	5.74	5.74	5.74	8.75	5.37	6.20		6.20	6.20	6.20	15.57
4500	3.98	5.08		5.08	5.08	5.08	5.08	7.07	4.47	5.45		5.45	5.45	5.45	12.57
4800	3.40	4.53		4.53	4.53	4.53	4.53	5.79	3.78	4.82		4.82	4.82	4.82	10.30
5100	2.92	4.05		3.69	4.05	4.05	4.05	4.81	3.24	4.30		4.30	4.30	4.30	8.54
5400	2.53	3.64		3.02	3.64	3.64	3.64	4.03	2.80	3.85		3.85	3.85	3.85	7.16
5700	2.21	3.28		2.50	3.28	3.28	3.28	3.42	2.44	3.46		3.46	3.46	3.46	6.07
6000	1.95	2.91		2.09	2.91	2.91	2.91	2.92	2.15	3.08		2.99	3.08	3.08	5.24
6300	1.73	2.60		1.76	2.60	2.60	2.60	2.51	1.90	2.75		2.58	2.75	2.75	4.55
6600	1.54	2.33		1.50	2.33	2.33	2.33	2.18	1.69	2.47		2.21	2.47	2.47	3.98
6900	1.38	2.11		1.28	2.11	2.11	2.11	1.91	1.52	2.23		1.91	2.23	2.23	3.50
7200	1.24	1.91		1.07	1.89	1.91	1.91	1.70	1.36	2.02		1.65	2.02	2.02	3.10
7500	1.13	1.74		0.93	1.67	1.74	1.74	1.53	1.23	1.84		1.44	1.84	1.84	2.75
7800	1.02	1.60		0.82	1.48	1.60	1.60	1.37	1.12	1.69		1.27	1.69	1.69	2.44
8100	0.93	1.47		0.72	1.30	1.47	1.47	1.24	1.02	1.55		1.12	1.55	1.55	2.18
8400	0.85	1.35		0.64	1.14	1.35	1.35	1.12	0.93	1.43		0.99	1.43	1.43	1.96
8700	0.78	1.25		0.57	1.01	1.25	1.25	1.02	0.85	1.32		0.88	1.32	1.32	1.76
9000	0.71	1.16		0.51	0.90	1.16	1.16	0.93	0.78	1.22		0.79	1.22	1.22	1.60
9300	0.65	1.16		0.47	0.83	1.16	1.16	0.86	0.71	1.22		0.70	1.21	1.22	1.47
9600	0.60	1.08		0.42	0.74	1.06	1.08	0.78	0.65	1.14		0.64	1.10	1.14	1.34
9900	0.56	1.00			0.67	0.97	1.00	0.71	0.60	1.06		0.58	1.00	1.06	1.22
10200	0.51	0.94			0.60	0.89	0.94	0.65	0.56	0.99		0.53	0.91	0.99	1.12
10500	0.48	0.88			0.54	0.81	0.88	0.60	0.52	0.93		0.48	0.83	0.93	1.02
10800	0.45	0.82			0.47	0.73	0.82	0.55	0.48	0.87		0.44	0.75	0.87	0.94
Sections below exceed the normal delivery length of 12000mm															
11100	0.42	0.78			0.43	0.66	0.78	0.51	0.45	0.82		0.40	0.68	0.82	0.86
11400		0.73				0.61	0.73	0.47	0.42	0.77			0.63	0.77	0.80
11700		0.69				0.55	0.69	0.44		0.73			0.57	0.73	0.73
12000		0.65				0.51	0.65	0.41		0.69			0.53	0.69	0.68

Bold capacities require grade 8.8 purlin bolts.

Values above dotted horizontal line in body of table are governed by the strength of the grade 8.8 bolt.

INWARD = Inward load capacity. OUTWARD = Outward load capacity. L/150 = Load for deflection span/150.

See also: Design notes for capacity tables.

Note: In mixed spans, the thicker sections is used in the end span.

Four Lapped Spans

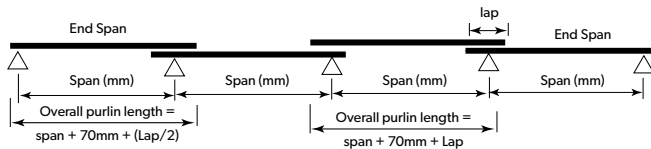

Bridging > Span mm	Z 20019 (kN/m)						L/150	Z 20024 (kN/m)						L/150	Z 25019 (kN/m)						L/150				
	INWARD			OUTWARD				INWARD				OUTWARD				INWARD			OUTWARD						
	0	1	2,3	0	1	2		3	0	1	2	3	0		1	2	3	0	1	2,3		0	1	2	3
3000	14.21	18.71	18.71	18.71	18.71	18.71	18.71	35.18	18.71	18.71	18.71	18.71	18.71	18.71	18.71	18.71	46.45	16.52	16.52	16.52	16.52	16.52	16.52	16.52	57.13
3300	11.11	16.38	16.38	16.38	16.38	16.38	16.38	26.22	14.52	17.04	17.04	17.04	17.04	17.04	17.04	17.04	34.62	14.29	14.29	14.29	14.29	14.29	14.29	14.29	42.58
3600	8.92	13.72	13.72	13.72	13.72	13.72	13.72	20.05	11.35	15.65	15.65	15.65	15.65	15.65	15.65	15.65	26.47	11.46	12.49	12.49	12.49	12.49	12.49	12.49	32.56
3900	7.31	11.63	11.63	11.63	11.63	11.63	11.63	15.66	9.10	14.47	14.47	14.47	14.47	14.47	14.47	14.47	20.68	9.36	11.01	11.01	11.01	11.01	11.01	11.01	25.43
4200	6.09	9.99	9.99	9.99	9.99	9.99	9.99	12.46	7.44	13.45	13.45	13.45	13.45	13.45	13.45	13.45	16.45	7.75	9.78	9.78	9.78	9.78	9.78	9.78	20.24
4500	5.13	8.66	8.66	8.66	8.66	8.66	8.66	10.07	6.19	12.57	12.57	12.57	12.57	12.57	12.57	12.57	13.30	6.48	8.73	8.73	8.73	8.73	8.73	8.73	16.36
4800	4.36	7.56	7.56	7.56	7.56	7.56	7.56	8.26	5.23	10.99	10.99	10.99	10.99	10.99	10.99	10.99	10.90	5.50	7.84	7.84	7.84	7.84	7.84	7.84	13.41
5100	3.73	6.52	6.52	6.52	6.52	6.52	6.52	6.85	4.46	9.48	9.48	9.48	9.48	9.48	9.48	9.48	9.05	4.70	7.07	7.07	7.07	7.07	7.07	7.07	11.13
5400	3.23	5.68	5.68	5.68	5.68	5.68	5.68	5.75	3.85	8.26	8.26	8.26	8.26	8.26	8.26	8.26	7.59	4.07	6.40	6.40	6.40	6.40	6.40	6.40	9.33
5700	2.82	5.00	5.00	5.00	5.00	5.00	5.00	4.87	3.35	7.26	7.26	7.26	7.26	7.26	7.26	7.26	6.43	3.55	5.82	5.82	5.82	5.82	5.82	5.82	7.90
6000	2.48	4.43	4.43	2.99	4.43	4.43	4.43	4.16	2.94	6.37	6.44	6.44	4.21	6.33	6.44	6.44	5.49	3.12	5.31	5.31	3.93	5.31	5.31	5.31	6.75
6300	2.20	3.95	3.95	2.55	3.95	3.95	3.95	3.58	2.60	5.63	5.75	5.75	3.55	5.53	5.75	5.75	4.73	2.76	4.86	4.86	3.34	4.86	4.86	4.86	5.81
6600	1.96	3.55	3.55	2.19	3.55	3.55	3.55	3.12	2.32	5.01	5.16	5.16	3.00	4.85	5.16	5.16	4.14	2.46	4.46	4.46	2.86	4.46	4.46	4.46	5.04
6900	1.75	3.21	3.21	1.88	3.12	3.21	3.21	2.74	2.08	4.49	4.66	4.66	2.55	4.28	4.66	4.66	3.65	2.20	4.07	4.07	2.44	4.07	4.07	4.07	4.40
7200	1.58	2.91	2.91	1.62	2.75	2.91	2.91	2.41	1.87	4.04	4.23	4.23	2.18	3.80	4.23	4.23	3.23	1.98	3.70	3.70	2.09	3.68	3.70	3.70	3.86
7500	1.43	2.65	2.65	1.40	2.42	2.65	2.65	2.14	1.69	3.65	3.86	3.86	1.88	3.38	3.86	3.86	2.87	1.79	3.37	3.37	1.81	3.22	3.37	3.37	3.40
7800	1.30	2.43	2.43	1.22	2.12	2.43	2.43	1.91	1.54	3.32	3.53	3.53	1.63	3.00	3.53	3.53	2.57	1.63	3.08	3.08	1.57	2.81	3.08	3.08	3.02
8100	1.18	2.23	2.23	1.07	1.87	2.23	2.23	1.71	1.40	3.02	3.25	3.25	1.42	2.67	3.24	3.25	2.31	1.48	2.83	2.83	1.37	2.40	2.83	2.83	2.71
8400	1.08	2.06	2.06	0.94	1.60	2.06	2.06	1.54	1.28	2.77	2.99	2.99	1.25	2.35	2.94	2.99	2.07	1.36	2.61	2.61	1.21	2.12	2.61	2.61	2.45
8700	0.99	1.91	1.91	0.83	1.43	1.91	1.91	1.39	1.17	2.54	2.77	2.77	1.10	2.08	2.67	2.77	1.86	1.24	2.42	2.42	1.06	1.89	2.42	2.42	2.23
9000	0.91	1.77	1.77	0.73	1.28	1.77	1.77	1.26	1.08	2.34	2.57	2.57	0.98	1.85	2.44	2.57	1.68	1.14	2.24	2.24	0.94	1.69	2.24	2.24	2.04
9300	0.86	1.73	1.76	0.67	1.20	1.70	1.76	1.16	1.01	2.27	2.56	2.56	0.89	1.71	2.35	2.56	1.55	1.07	2.23	2.23	0.85	1.58	2.23	2.23	1.88
9600	0.79	1.59	1.64	0.59	1.08	1.55	1.64	1.06	0.93	2.09	2.38	2.38	0.79	1.54	2.14	2.38	1.41	0.99	2.08	2.08	0.75	1.42	2.08	2.08	1.72
9900	0.73	1.48	1.53	0.53	0.98	1.41	1.53	0.97	0.87	1.94	2.21	2.22	0.71	1.38	1.96	2.22	1.29	0.92	1.94	1.94	0.67	1.28	1.88	1.94	1.58
10200	0.68	1.37	1.43	0.47	0.89	1.28	1.43	0.89	0.80	1.80	2.05	2.08	0.64	1.24	1.80	2.04	1.18	0.85	1.81	1.81	0.60	1.16	1.70	1.81	1.46
10500	0.63	1.27	1.34	0.43	0.81	1.16	1.34	0.82	0.75	1.68	1.91	1.95	0.58	1.11	1.65	1.89	1.08	0.79	1.68	1.70	0.54	1.05	1.54	1.70	1.34
10800	0.59	1.19	1.26	0.73	1.05	1.26	1.26	0.75	0.70	1.56	1.78	1.83	0.52	1.00	1.51	1.75	1.00	0.74	1.57	1.59	0.49	0.94	1.35	1.59	1.23
Sections below exceed the normal delivery length of 12000mm																									
11100	0.55	1.11	1.18	0.66	0.93	1.18	1.18	0.70	0.65	1.46	1.66	1.72	0.47	0.91	1.38	1.63	0.92	0.69	1.46	1.50	0.44	0.85	1.24	1.50	1.14
11400	0.52	1.04	1.11	0.60	0.85	1.10	1.10	0.64	0.61	1.36	1.55	1.62	0.43	0.82	1.25	1.51	0.85	0.64	1.36	1.41	0.40	0.77	1.13	1.41	1.05
11700	0.48	0.97	1.05	0.55	0.79	1.02	1.02	0.60	0.57	1.27	1.46	1.53	0.75	1.15	1.41	1.41	0.78	0.60	1.27	1.33	0.70	1.04	1.33	1.33	0.97
12000	0.45	0.91	0.99	0.50	0.72	0.95	0.95	0.56	0.54	1.19	1.37	1.45	0.68	1.05	1.31	1.31	0.73	0.56	1.18	1.26	0.64	0.96	1.26	1.26	0.91

Bold capacities require grade 8.8 purlin bolts.

Values above dotted horizontal line in body of table are governed by the strength of the grade 8.8 bolt.

INWARD = Inward load capacity. OUTWARD = Outward load capacity. L/150 = Load for deflection span/150.

See also: Design notes for capacity tables.

Four Lapped Spans

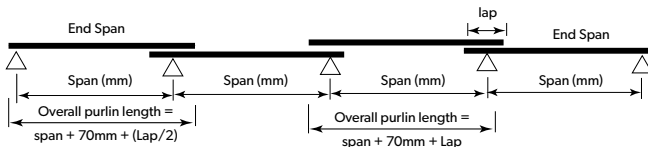

Bridging > Span mm	Z 25019/25024 (kN/m)								L/150	Z 25024 (kN/m)								L/150
	INWARD				OUTWARD					INWARD				OUTWARD				
	0	1	2, 3		0	1	2	3		0	1	2	3	0	1	2	3	
3000	18.72	18.72	18.72	18.72	18.72	18.72	18.72	76.40	18.71	18.71	18.71	18.71	18.71	18.71	18.71	18.71	78.80	
3300	15.97	15.97	15.97	15.97	15.97	15.97	15.97	56.91	17.04	17.04	17.04	17.04	17.04	17.04	17.04	17.04	58.73	
3600	12.77	13.79	13.79	13.79	13.79	13.79	13.79	43.50	14.20	15.65	15.65	15.65	15.65	15.65	15.65	15.65	44.90	
3900	10.19	12.03	12.03	12.03	12.03	12.03	12.03	33.97	11.35	14.47	14.47	14.47	14.47	14.47	14.47	14.47	35.08	
4200	8.32	10.58	10.58	10.58	10.58	10.58	10.58	27.02	9.27	13.45	13.45	13.45	13.45	13.45	13.45	13.45	27.91	
4500	6.91	9.37	9.37	9.37	9.37	9.37	9.37	21.84	7.70	12.57	12.57	12.57	12.57	12.57	12.57	12.57	22.56	
4800	5.82	8.35	8.35	8.35	8.35	8.35	8.35	17.90	6.48	11.80	11.80	11.80	11.80	11.80	11.80	11.80	18.50	
5100	4.97	7.49	7.49	7.49	7.49	7.49	7.49	14.85	5.53	11.12	11.12	11.12	11.12	9.68	11.12	11.12	15.35	
5400	4.29	6.74	6.74	6.74	6.74	6.74	6.74	12.46	4.76	10.51	10.51	10.51	10.51	7.90	10.51	10.51	12.87	
5700	3.74	6.10	6.10	6.10	6.10	6.10	6.10	10.55	4.14	9.31	9.31	9.31	9.31	6.53	9.31	9.31	10.90	
6000	3.28	5.54	5.54	5.54	5.54	5.54	5.54	9.01	3.63	8.26	8.26	8.26	8.26	5.47	8.26	8.26	9.31	
6300	2.90	5.05	5.05	5.05	5.05	5.05	5.05	7.76	3.21	7.37	7.37	7.37	7.37	4.60	7.37	7.37	8.01	
6600	2.59	4.63	4.63	4.63	4.63	4.63	4.63	6.73	2.86	6.62	6.62	6.62	6.62	3.87	6.49	6.62	6.95	
6900	2.31	4.19	4.19	4.19	4.19	4.19	4.19	5.87	2.56	5.97	5.98	5.98	5.98	3.28	5.72	5.98	6.06	
7200	2.08	3.80	3.80	3.80	3.80	3.80	3.80	5.16	2.30	5.36	5.42	5.42	5.42	2.80	5.05	5.42	5.32	
7500	1.88	3.47	3.47	3.47	3.47	3.47	3.47	4.58	2.08	4.84	4.95	4.95	4.95	2.41	4.48	4.95	4.70	
7800	1.71	3.17	3.17	3.17	3.17	3.17	3.17	4.09	1.89	4.39	4.53	4.53	4.53	2.09	3.95	4.53	4.19	
8100	1.56	2.91	2.91	2.91	2.91	2.91	2.91	3.66	1.72	4.00	4.16	4.16	4.16	1.82	3.48	4.16	3.75	
8400	1.42	2.69	2.69	2.69	2.69	2.69	2.69	3.30	1.57	3.66	3.84	3.84	3.84	1.59	3.07	3.84	3.38	
8700	1.30	2.49	2.49	2.49	2.49	2.49	2.49	2.98	1.44	3.36	3.55	3.55	3.55	1.40	2.71	3.55	3.06	
9000	1.20	2.31	2.31	2.31	2.31	2.31	2.31	2.70	1.33	3.09	3.29	3.29	3.29	1.23	2.41	3.26	2.77	
9300	1.13	2.30	2.30	2.30	2.30	2.30	2.30	2.49	1.23	2.97	3.28	3.28	3.28	1.12	2.22	3.13	2.55	
9600	1.04	2.14	2.14	2.14	2.14	2.14	2.14	2.27	1.14	2.74	3.05	3.05	3.05	1.00	1.99	2.85	2.33	
9900	0.96	1.99	1.99	1.99	1.99	1.99	1.99	2.07	1.06	2.53	2.85	2.85	2.85	0.89	1.78	2.61	2.13	
10200	0.89	1.86	1.86	1.86	1.86	1.86	1.86	1.89	0.98	2.34	2.66	2.66	2.66	0.80	1.59	2.38	1.96	
10500	0.83	1.75	1.75	1.75	1.75	1.75	1.75	1.74	0.91	2.17	2.49	2.49	2.49	0.72	1.43	2.17	1.80	
10800	0.77	1.64	1.64	1.64	1.64	1.64	1.64	1.60	0.85	2.02	2.34	2.34	2.34	0.65	1.28	1.97	1.65	
Sections below exceed the normal delivery length of 12000mm																		
11100	0.72	1.54	1.54	1.54	1.54	1.54	1.54	1.47	0.80	1.88	2.20	2.20	2.20	0.59	1.16	1.79	1.52	
11400	0.67	1.45	1.45	1.45	1.45	1.45	1.45	1.36	0.74	1.75	2.07	2.08	2.08	0.53	1.05	1.63	1.40	
11700	0.63	1.37	1.37	1.37	1.37	1.37	1.37	1.26	0.70	1.64	1.94	1.96	1.96	0.49	0.95	1.49	1.30	
12000	0.59	1.28	1.30	1.30	1.30	1.30	1.30	1.17	0.65	1.53	1.82	1.85	1.85	0.44	0.87	1.36	1.20	

Bold capacities require grade 8.8 purlin bolts.

Values above dotted horizontal line in body of table are governed by the strength of the grade 8.8 bolt.

INWARD = Inward load capacity. OUTWARD = Outward load capacity. L/150 = Load for deflection span/150.

See also: Design notes for capacity tables.

Note: In mixed spans, the thicker sections is used in the end span.

Four Lapped Spans

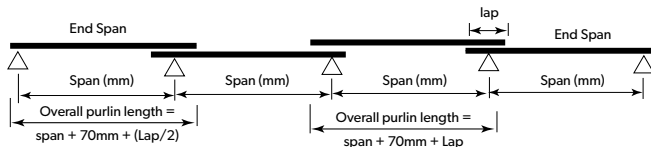

Span mm	Z 30024 (kN/m)									L/150	Z 30024/30030 (kN/m)									L/150
	INWARD				OUTWARD				L/150		INWARD				OUTWARD				L/150	
	0	1	2	3	0	1	2	3			0	1	2	3	0	1	2	3		
6000	5.40	9.68	9.68	9.68	9.68	9.68	9.68	9.68	9.68	15.45	5.84	10.24	10.24	10.24	10.24	10.24	10.24	10.24	10.24	20.01
6300	4.73	8.90	8.90	8.90	8.86	8.90	8.90	8.90	8.90	13.30	5.10	9.38	9.38	9.38	9.38	9.38	9.38	9.38	9.38	17.23
6600	4.17	8.21	8.21	8.21	7.55	8.21	8.21	8.21	8.21	11.53	4.49	8.62	8.62	8.62	8.62	8.62	8.62	8.62	8.62	14.94
6900	3.70	7.59	7.59	7.59	6.39	7.59	7.59	7.59	7.59	10.06	3.98	7.94	7.94	7.94	7.94	7.69	7.94	7.94	7.94	13.03
7200	3.31	7.03	7.03	7.03	5.57	7.03	7.03	7.03	7.03	8.83	3.55	7.34	7.34	7.34	7.34	6.66	7.34	7.34	7.34	11.44
7500	2.98	6.53	6.53	6.53	4.89	6.53	6.53	6.53	6.53	7.79	3.19	6.80	6.80	6.80	6.80	5.80	6.80	6.80	6.80	10.09
7800	2.69	6.08	6.08	6.08	4.32	6.08	6.08	6.08	6.08	6.91	2.88	6.32	6.32	6.32	6.32	5.00	6.32	6.32	6.32	8.95
8100	2.44	5.68	5.68	5.68	3.83	5.68	5.68	5.68	5.68	6.16	2.61	5.87	5.87	5.87	5.87	4.44	5.87	5.87	5.87	7.98
8400	2.22	5.27	5.27	5.27	3.38	5.27	5.27	5.27	5.27	5.51	2.37	5.41	5.41	5.41	5.41	3.96	5.41	5.41	5.41	7.14
8700	2.03	4.87	4.87	4.87	2.99	4.87	4.87	4.87	4.87	4.95	2.17	5.01	5.01	5.01	5.01	3.54	5.01	5.01	5.01	6.46
9000	1.86	4.52	4.52	4.52	2.67	4.49	4.52	4.52	4.52	4.46	1.99	4.64	4.64	4.64	4.64	3.19	4.64	4.64	4.64	5.87
9300	1.73	4.40	4.51	4.51	2.43	4.27	4.51	4.51	4.51	4.11	1.84	4.63	4.63	4.63	4.63	2.98	4.63	4.63	4.63	5.40
9600	1.60	4.05	4.19	4.19	2.15	3.86	4.19	4.19	4.19	3.76	1.70	4.31	4.31	4.31	4.31	2.67	4.31	4.31	4.31	4.94
9900	1.48	3.74	3.91	3.91	1.92	3.48	3.91	3.91	3.91	3.46	1.57	4.01	4.02	4.02	4.02	2.40	4.01	4.02	4.02	4.53
10200	1.37	3.46	3.65	3.65	1.72	3.14	3.65	3.65	3.65	3.19	1.46	3.71	3.76	3.76	3.76	2.16	3.67	3.76	3.76	4.16
10500	1.28	3.21	3.42	3.42	1.54	2.84	3.42	3.42	3.42	2.95	1.36	3.44	3.52	3.52	3.52	1.94	3.36	3.52	3.52	3.83
10800	1.19	2.98	3.21	3.21	1.39	2.53	3.21	3.21	3.21	2.72	1.27	3.20	3.30	3.30	3.30	1.75	3.09	3.30	3.30	3.54
Sections below exceed the normal delivery length of 12000mm																				
11100	1.11	2.76	3.02	3.02	1.25	2.32	3.02	3.02	2.51	1.18	2.98	3.11	3.11	3.11	3.11	1.59	2.82	3.11	3.11	3.27
11400	1.04	2.57	2.85	2.85	1.13	2.13	2.85	2.85	2.33	1.11	2.78	2.93	2.93	2.93	2.93	1.44	2.58	2.93	2.93	3.02
11700	0.98	2.40	2.69	2.69	1.03	1.96	2.69	2.69	2.15	1.04	2.61	2.76	2.76	2.76	2.76	1.31	2.36	2.76	2.76	2.80
12000	0.92	2.24	2.54	2.54	0.94	1.81	2.54	2.54	2.00	0.97	2.44	2.61	2.61	2.61	2.61	1.20	2.17	2.61	2.61	2.60
12300	0.87	2.18	2.68	2.68	0.89	1.78	2.53	2.68	1.90	0.93	2.38	2.75	2.75	2.75	2.75	1.13	2.08	2.75	2.75	2.47
12600	0.82	2.00	2.53	2.53	0.81	1.63	2.35	2.53	1.77	0.87	2.23	2.60	2.60	2.60	2.60	1.04	1.93	2.60	2.60	2.30
12900	0.77	1.88	2.40	2.40	0.74	1.50	2.16	2.40	1.65	0.82	2.09	2.47	2.47	2.47	2.47	0.95	1.79	2.47	2.47	2.15
13200	0.73	1.77	2.27	2.27	0.68	1.38	2.00	2.27	1.54	0.78	1.96	2.34	2.34	2.34	2.34	0.88	1.66	2.33	2.34	2.01
13500	0.69	1.67	2.16	2.16	0.63	1.28	1.85	2.16	1.44	0.74	1.85	2.22	2.22	2.22	2.22	0.81	1.54	2.18	2.22	1.88
13800	0.66	1.58	2.05	2.05	0.58	1.18	1.72	2.05	1.35	0.70	1.74	2.11	2.11	2.11	2.11	0.75	1.44	2.04	2.11	1.76
14100	0.62	1.49	1.95	1.95	0.53	1.09	1.59	1.95	1.27	0.66	1.64	2.01	2.01	2.01	2.01	0.69	1.34	1.91	2.01	1.65
14400	0.59	1.41	1.85	1.86	0.49	1.00	1.46	1.86	1.20	0.63	1.55	1.92	1.92	1.92	1.92	0.64	1.25	1.79	1.92	1.54
14700	0.56	1.34	1.75	1.78	0.46	0.93	1.36	1.76	1.13	0.60	1.44	1.83	1.83	1.83	1.83	0.59	1.16	1.67	1.83	1.45
15000	0.53	1.27	1.66	1.70	0.42	0.86	1.28	1.66	1.06	0.57	1.37	1.75	1.75	1.75	1.75	0.55	1.08	1.56	1.75	1.36
15300	0.51	1.21	1.57	1.62		0.80	1.20	1.57	1.01	0.54	1.30	1.67	1.67	1.67	1.67	0.52	1.01	1.46	1.67	1.28
15600	0.48	1.15	1.49	1.56		0.74	1.13	1.48	0.95	0.51	1.24	1.60	1.60	1.60	1.60	0.48	0.95	1.36	1.60	1.21
15900	0.46	1.09	1.42	1.49		0.69	1.06	1.39	0.90	0.49	1.18	1.53	1.53	1.53	1.53	0.45	0.88	1.28	1.53	1.14
16200	0.44	1.04	1.35	1.43		0.64	1.00	1.31	0.86	0.47	1.12	1.46	1.47	1.47	1.47	0.42	0.82	1.20	1.47	1.08
16500	0.42	0.99	1.29	1.37		0.60	0.94	1.23	0.81	0.45	1.07	1.39	1.41	1.41	1.41		0.77	1.11	1.41	1.02
16800	0.40	0.95	1.22	1.32		0.56	0.89	1.16	0.77	0.43	1.02	1.33	1.35	1.35	1.35		0.72	1.05	1.35	0.96
17100		0.91	1.16	1.27		0.52	0.84	1.09	0.74	0.41	0.98	1.27	1.30	1.30	1.30		0.67	0.99	1.28	0.91
17400		0.87	1.11	1.22		0.49	0.79	1.03	0.70		0.93	1.21	1.25	1.25	1.25		0.63	0.94	1.21	0.87

Bold capacities require grade 8.8 purlin bolts.
 Values above dotted horizontal line in body of table are governed by the strength of the grade 8.8 bolt.
 INWARD = Inward load capacity. OUTWARD = Outward load capacity. L/150 = Load for deflection span/150.
 See also: Design notes for capacity tables.
 Note: In mixed spans, the thicker sections is used in the end span.

Four Lapped Spans

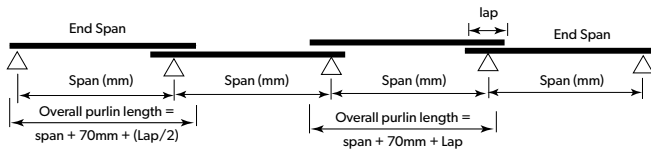

Bridging > Span mm	Z 30030 (kN/m)					L/150	Z 35030 (kN/m)					L/150						
	INWARD				OUTWARD				INWARD				OUTWARD					
	0	1	2	3	0		1	2	3	0	1		2	3	0	1	2	3
6000	6.38	15.60	15.60	15.60	14.54	15.60	15.60	15.60	20.61	9.82	16.52	16.52	16.52	16.52	16.52	16.52	16.52	32.00
6300	5.56	14.14	14.14	14.14	12.49	14.14	14.14	14.14	17.74	8.51	15.22	15.22	15.22	15.22	15.22	15.22	15.22	27.54
6600	4.89	12.88	12.88	12.88	10.66	12.88	12.88	12.88	15.38	7.43	14.06	14.06	14.06	14.06	14.06	14.06	14.06	23.88
6900	4.33	11.70	11.70	11.70	9.18	11.70	11.70	11.70	13.42	6.50	13.02	13.02	13.02	13.02	13.02	13.02	13.02	20.84
7200	3.86	10.60	10.62	10.62	7.89	10.62	10.62	10.62	11.78	5.74	12.09	12.09	12.09	12.09	12.09	12.09	12.09	18.29
7500	3.46	9.56	9.68	9.68	6.79	9.68	9.68	9.68	10.40	5.09	11.24	11.24	11.24	11.24	11.24	11.24	11.24	16.14
7800	3.12	8.65	8.87	8.87	5.88	8.87	8.87	8.87	9.22	4.55	10.48	10.48	10.48	9.96	10.48	10.48	10.48	14.31
8100	2.83	7.86	8.15	8.15	5.12	8.15	8.15	8.15	8.21	4.08	9.79	9.79	9.79	8.77	9.79	9.79	9.79	12.75
8400	2.57	7.17	7.51	7.51	4.48	7.39	7.51	7.51	7.35	3.69	9.16	9.16	9.16	7.76	9.16	9.16	9.16	11.41
8700	2.35	6.56	6.95	6.95	3.94	6.72	6.95	6.95	6.60	3.34	8.51	8.51	8.51	6.88	8.51	8.51	8.51	10.25
9000	2.15	6.03	6.45	6.45	3.48	6.13	6.45	6.45	5.98	3.04	7.89	7.89	7.89	6.13	7.89	7.89	7.89	9.24
9300	2.00	5.83	6.42	6.42	3.17	5.90	6.42	6.42	5.51	2.80	7.86	7.86	7.86	5.54	7.86	7.86	7.86	8.50
9600	1.84	5.38	5.97	5.97	2.81	5.39	5.97	5.97	5.03	2.57	7.31	7.31	7.31	5.00	7.31	7.31	7.31	7.72
9900	1.70	4.96	5.57	5.57	2.51	4.92	5.57	5.57	4.61	2.37	6.80	6.82	6.82	4.53	6.82	6.82	6.82	7.02
10200	1.58	4.58	5.21	5.21	2.25	4.47	5.21	5.21	4.24	2.18	6.28	6.38	6.38	4.11	6.38	6.38	6.38	6.41
10500	1.47	4.24	4.88	4.88	2.02	4.05	4.88	4.88	3.91	2.02	5.80	5.97	5.97	3.74	5.97	5.97	5.97	5.86
10800	1.37	3.92	4.58	4.58	1.82	3.68	4.58	4.58	3.61	1.88	5.38	5.61	5.61	3.42	5.61	5.61	5.61	5.38
Sections below exceed the normal delivery length of 12000mm																		
11100	1.28	3.63	4.31	4.31	1.65	3.36	4.28	4.31	3.34	1.75	5.00	5.28	5.28	3.13	5.28	5.28	5.28	4.99
11400	1.20	3.38	4.06	4.06	1.49	3.06	3.98	4.06	3.10	1.63	4.65	4.97	4.97	2.87	4.91	4.97	4.97	4.65
11700	1.13	3.15	3.84	3.84	1.36	2.78	3.71	3.84	2.88	1.52	4.32	4.69	4.69	2.62	4.55	4.69	4.69	4.34
12000	1.06	2.94	3.63	3.63	1.24	2.53	3.47	3.63	2.67	1.43	4.02	4.44	4.44	2.39	4.22	4.44	4.44	4.04
12300	1.01	2.85	3.71	3.82	1.17	2.40	3.50	3.82	2.54	1.35	3.92	4.67	4.67	2.31	4.13	4.67	4.67	3.83
12600	0.95	2.66	3.49	3.61	1.07	2.19	3.27	3.61	2.36	1.27	3.65	4.42	4.42	2.12	3.81	4.42	4.42	3.57
12900	0.90	2.49	3.28	3.42	0.99	2.01	3.06	3.42	2.21	1.20	3.41	4.18	4.18	1.95	3.51	4.18	4.18	3.33
13200	0.85	2.33	3.09	3.24	0.91	1.84	2.84	3.24	2.06	1.13	3.19	3.97	3.97	1.79	3.24	3.97	3.97	3.11
13500	0.80	2.19	2.91	3.08	0.83	1.69	2.64	3.05	1.93	1.07	2.99	3.77	3.77	1.64	3.00	3.77	3.77	2.92
13800	0.76	2.06	2.75	2.93	0.77	1.56	2.45	2.87	1.81	1.01	2.81	3.58	3.58	1.51	2.78	3.58	3.58	2.73
14100	0.72	1.94	2.60	2.79	0.71	1.44	2.28	2.70	1.70	0.96	2.64	3.41	3.41	1.39	2.58	3.41	3.41	2.57
14400	0.69	1.83	2.46	2.66	0.66	1.33	2.12	2.55	1.59	0.91	2.49	3.25	3.25	1.29	2.40	3.25	3.25	2.41
14700	0.65	1.73	2.34	2.53	0.61	1.23	1.98	2.41	1.50	0.86	2.35	3.10	3.10	1.19	2.18	3.10	3.10	2.27
15000	0.62	1.63	2.22	2.42	0.57	1.14	1.84	2.28	1.41	0.82	2.22	2.96	2.96	1.11	2.04	2.95	2.95	2.14
15300	0.59	1.54	2.11	2.32	0.53	1.06	1.72	2.16	1.32	0.78	2.10	2.83	2.83	1.03	1.91	2.78	2.83	2.02
15600	0.56	1.46	2.00	2.22	0.50	0.99	1.60	2.04	1.25	0.74	1.99	2.71	2.71	0.96	1.80	2.63	2.71	1.91
15900	0.54	1.39	1.91	2.12	0.46	0.92	1.49	1.93	1.18	0.71	1.89	2.60	2.60	0.89	1.69	2.48	2.60	1.81
16200	0.51	1.32	1.82	2.04	0.43	0.86	1.39	1.84	1.11	0.68	1.75	2.49	2.49	0.83	1.59	2.34	2.49	1.71
16500	0.49	1.25	1.73	1.96	0.41	0.80	1.30	1.74	1.05	0.65	1.66	2.39	2.39	0.78	1.50	2.21	2.39	1.62
16800	0.47	1.19	1.64	1.88		0.75	1.21	1.65	0.99	0.62	1.59	2.28	2.30	0.73	1.41	2.08	2.30	1.54
17100	0.45	1.14	1.57	1.81		0.70	1.14	1.55	0.94	0.59	1.51	2.17	2.21	0.68	1.33	1.96	2.21	1.46
17400	0.43	1.08	1.49	1.74		0.66	1.07	1.47	0.89	0.57	1.45	2.07	2.13	0.64	1.26	1.85	2.13	1.39

Bold capacities require grade 8.8 purlin bolts.
 Values above dotted horizontal line in body of table are governed by the strength of the grade 8.8 bolt.
 INWARD = Inward load capacity. OUTWARD = Outward load capacity. L/150 = Load for deflection span/150.
 See also: Design notes for capacity tables.

Four Lapped Spans

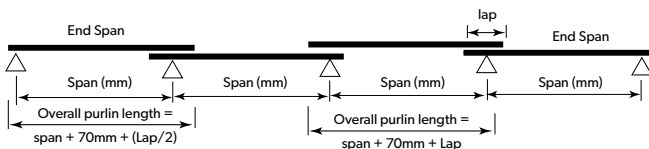

CANTILEVER SPANS

Section	End Span mm	CANTILEVER 1000mm (kN/m)							CANTILEVER 2000mm (kN/m)						
		IN BRIDGING			OUT BRIDGING			L/150	IN BRIDGING			OUT BRIDGING			L/150
		0	1	2	0	1	2		0	1	2	0	1	2	
Z/C 10010	2000	4.38	4.38	4.38	4.38	4.38	4.38	3.50							
	4000	1.25	1.25	1.25	0.62	1.12	1.25	0.26	0.91	1.10	1.10	0.99	1.10	1.10	0.48
	6000	0.52	0.52	0.52	0.14	0.26	0.43	0.06	0.59	0.61	0.61	0.18	0.32	0.52	0.12
Z/C10012	2000	5.33	5.33	5.33	5.33	5.33	5.33	4.26							
	4000	1.52	1.52	1.52	0.79	1.36	1.52	0.31	1.09	1.33	1.33	1.20	1.33	1.33	0.57
	6000	0.63	0.63	0.63	0.18	0.33	0.52	0.07	0.67	0.75	0.75	0.22	0.40	0.64	0.14
Z/C10015	2000	6.95	6.95	6.95	6.95	6.95	6.95	5.60							
	4000	1.83	1.98	1.98	1.05	1.73	1.98	0.38	1.43	1.69	1.74	1.53	1.74	1.74	0.72
	6000	0.74	0.82	0.82	0.24	0.45	0.69	0.09	0.81	0.97	0.97	0.30	0.55	0.83	0.17
Z/C 10019	2000	9.69	9.69	9.69	9.69	9.69	9.69	7.18							
	4000	2.41	2.76	2.76	1.41	2.41	2.76	0.48	1.94	2.41	2.42	2.13	2.42	2.42	0.90
	6000	0.96	1.14	1.14	0.34	0.60	0.95	0.12	1.01	1.36	1.36	0.42	0.74	1.15	0.22
Z/C15012	2000	6.87	6.87	6.87	6.87	6.87	6.87	11.35							
	4000	2.65	2.65	2.65	1.92	2.65	2.65	0.91	2.31	2.33	2.33	2.33	2.33	2.33	1.59
	6000	1.10	1.10	1.10	0.46	0.82	1.10	0.22	1.20	1.31	1.31	0.56	1.00	1.31	0.42
	8000	0.60	0.60	0.60	0.16	0.30	0.49	0.09	0.62	0.66	0.66	0.17	0.33	0.54	0.11
Z/C 15015	2000	11.11	11.11	11.11	11.11	11.11	11.11	15.12							
	4000	3.37	3.49	3.49	2.48	3.49	3.49	1.14	2.87	3.06	3.06	3.06	3.06	3.06	2.09
	6000	1.33	1.44	1.44	0.59	1.06	1.44	0.27	1.40	1.72	1.72	0.73	1.28	1.72	0.52
	8000	0.71	0.79	0.79	0.20	0.41	0.64	0.11	0.72	0.87	0.87	0.22	0.45	0.71	0.14
Z/C 15019	2000	16.64	16.64	16.64	16.64	16.64	16.64	19.82							
	4000	4.24	4.92	4.92	3.46	4.92	4.92	1.43	3.74	4.32	4.32	4.25	4.32	4.32	2.68
	6000	1.64	2.04	2.04	0.78	1.50	1.98	0.34	1.74	2.42	2.42	0.95	1.83	2.38	0.65
	8000	0.86	1.10	1.11	0.28	0.54	0.88	0.14	0.88	1.21	1.23	0.30	0.59	0.98	0.18
Z/C 15024	2000	23.04	23.04	23.04	23.04	23.04	23.04	26.35							
	4000	5.43	6.93	6.93	4.68	6.93	6.93	1.80	5.02	6.09	6.09	6.02	6.09	6.09	3.38
	6000	1.98	2.86	2.87	1.06	2.06	2.82	0.43	2.06	3.37	3.41	1.29	2.52	3.38	0.82
	8000	1.01	1.48	1.57	0.39	0.72	1.23	0.17	1.03	1.62	1.73	0.43	0.80	1.37	0.23
Z/C 20015	4000	4.73	4.73	4.73	4.53	4.73	4.73	2.44	3.93	3.93	3.93	3.93	3.93	3.93	4.14
	6000	1.88	1.96	1.96	1.06	1.93	1.96	0.60	2.01	2.33	2.33	1.29	2.32	2.33	1.12
	8000	0.98	1.07	1.07	0.40	0.74	1.07	0.24	1.01	1.18	1.18	0.44	0.81	1.18	0.31
Z/C 20019	4000	6.53	7.20	7.20	6.55	7.20	7.20	3.21	6.04	6.33	6.33	6.33	6.33	6.33	5.59
	6000	2.30	2.98	2.98	1.66	2.82	2.98	0.77	2.49	3.54	3.54	1.94	3.39	3.54	1.47
	8000	1.19	1.63	1.63	0.56	1.07	1.61	0.30	1.24	1.80	1.80	0.62	1.18	1.79	0.40
Z/C 20024	4000	8.48	10.47	10.47	9.12	10.47	10.47	4.06	8.05	9.20	9.20	9.20	9.20	9.20	7.47
	6000	2.97	4.34	4.34	2.18	3.89	4.34	0.97	3.16	5.15	5.15	2.63	4.67	5.15	1.85
	8000	1.50	2.25	2.37	0.76	1.53	2.21	0.38	1.53	2.47	2.62	0.83	1.68	2.44	0.51
Z/C 25019	4000	8.50	9.14	9.14	8.72	9.14	9.14	5.35	6.98	6.98	6.98	6.98	6.98	6.98	9.14
	6000	3.00	3.79	3.79	2.09	3.77	2.79	1.30	3.16	4.31	4.31	2.39	4.31	4.31	2.02
	8000	1.53	2.07	2.07	0.72	1.41	2.07	0.51	1.59	2.28	2.28	0.79	1.55	2.28	0.68
	10000	0.93	1.31	1.31	0.31	0.64	1.03	0.26	0.95	1.39	1.39	0.33	0.68	1.10	0.30
Z/C 25024	4000	10.86	13.41	13.41	12.09	13.41	13.41	6.86	10.50	11.46	11.46	11.46	11.46	11.46	12.35
	6000	3.77	5.56	5.56	2.85	5.19	5.56	1.64	3.94	6.33	6.33	3.21	5.95	6.33	2.56
	8000	1.87	2.99	3.04	0.96	1.98	2.95	0.65	1.91	3.28	3.35	1.04	2.18	3.27	0.86
	10000	1.11	1.80	1.93	0.42	0.86	1.48	0.32	1.11	1.90	2.05	0.44	0.91	1.58	0.38

1. The capacities are for cantilevers with single end span. The ends of the cantilevers are stabilised by fascias, bridging, barge boards, perimeter beams or similar structural members.
2. Bold capacities require grade 8.8 purlin bolts.
3. Bridging shown is for end spans only.
4. See also Design notes for capacity tables

Cantilever spans

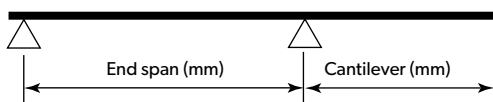

CANTILEVER SPANS

Section	End Span mm	CANTILEVER 3000mm (kN/m)						L/150
		IN BRIDGING			OUT BRIDGING			
		0	1	2	0	1	2	
Z/C 10010	2000							
	4000	0.25	0.37	0.43	0.49	0.49	0.49	0.07
	6000	0.24	0.34	0.38	0.26	0.43	0.49	0.14
Z/C10012	2000							
	4000	0.33	0.44	0.53	0.59	0.59	0.59	0.09
	6000	0.31	0.40	0.47	0.34	0.52	0.59	0.17
Z/C10015	2000							
	4000	0.45	0.62	0.68	0.77	0.77	0.77	0.11
	6000	0.42	0.57	0.63	0.46	0.67	0.77	0.21
Z/C 10019	2000							
	4000	0.62	0.86	0.95	1.08	1.08	1.08	0.13
	6000	0.58	0.79	0.88	0.65	0.95	1.08	0.27
Z/C15012	2000							
	4000	0.78	1.04	1.04	1.04	1.04	1.04	0.26
	6000	0.71	1.00	1.04	0.79	1.04	1.04	0.50
	8000	0.56	0.79	0.79	0.22	0.40	0.66	0.29
Z/C 15015	2000							
	4000	1.00	1.36	1.36	1.36	1.36	1.36	0.32
	6000	0.91	1.28	1.36	1.00	1.36	1.36	0.63
	8000	0.68	1.04	1.04	0.29	0.56	0.87	0.36
Z/C 15019	2000							
	4000	1.44	1.80	1.91	1.92	1.92	1.92	0.40
	6000	1.23	1.71	1.82	1.43	1.90	1.92	0.80
	8000	0.86	1.36	1.45	0.39	0.74	1.20	0.45
Z/C 15024	2000							
	4000	2.00	2.55	2.71	2.71	2.71	2.71	0.50
	6000	1.61	2.40	2.57	1.96	2.70	2.70	1.00
	8000	1.01	1.84	2.06	0.54	1.00	1.67	0.57
Z/C 20015	4000	1.80	1.85	1.85	1.85	1.85	1.85	0.70
	6000	1.50	1.85	1.85	1.80	1.85	1.85	1.29
	8000	1.00	1.41	1.41	0.55	1.01	1.41	0.76
Z/C 20019	4000	2.61	2.81	2.81	2.81	2.81	2.81	0.90
	6000	2.01	2.81	2.81	2.59	2.81	2.81	1.75
	8000	1.29	2.14	2.14	0.78	1.45	2.14	1.01
Z/C 20024	4000	3.62	4.09	4.09	4.09	4.09	4.09	1.13
	6000	2.73	4.04	4.09	3.59	4.09	4.09	2.25
	8000	1.54	2.89	3.11	1.04	2.08	2.95	1.28
Z/C 25019	4000	3.46	3.57	3.57	3.57	3.57	3.57	1.52
	6000	2.61	3.57	3.57	3.44	3.57	3.57	2.88
	8000	1.63	2.72	2.72	0.99	1.91	2.72	1.66
	10000	0.97	1.55	1.55	0.37	0.77	1.24	0.44
Z/C 25024	4000	4.79	5.24	5.24	5.24	5.24	5.24	1.92
	6000	3.46	5.24	5.24	4.75	5.24	5.24	3.80
	8000	1.92	3.83	3.99	1.31	2.70	3.94	2.16
	10000	1.12	2.10	2.28	0.50	1.03	1.79	0.55

1. The capacities are for cantilevers with single end span. The ends of the cantilevers are stabilised by fascias, bridging, barge boards, perimeter beams or similar structural members.
2. Bold capacities require grade 8.8 purlin bolts.
3. Bridging shown is for end spans only.
4. See also Design notes for capacity tables

Cantilever spans

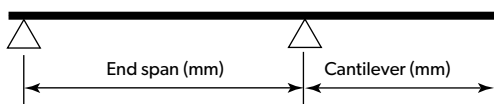

PRODUCT DESCRIPTIONS

- All descriptions, specifications, illustrations, drawings, data, dimensions, and weights contained in this publication and websites containing information from Lysaght are approximations only. They are intended by Lysaght to be a general description for information and identification purposes and do not create a sale by description. Lysaght reserves the right at any time to:

- Supply goods with such minor modifications from its drawings and specifications as it sees fit, and
- Alter specifications shown in its publications and websites to reflect changes made after the date of publication.

DISCLAIMER, WARRANTIES AND LIMITATION OF LIABILITY

- This publication is intended to be an aid for all trades and professionals involved with specifying and installing LYSAGHT® products and not be a substitute for professional judgement.
- Terms and conditions of sale are available at lysaght.com/terms
- Except to the extent to which liability may not lawfully be excluded or limited, BlueScope Steel Limited will not be under or incur any liability to you for any direct or indirect loss or damage (including, without limitation, consequential loss or damage such as loss of profit or anticipated profit, loss of use, damage to goodwill and loss due to delay) however caused (including, without limitation, breach of contract, negligence and/or breach of statute), which you may suffer or incur in connection with this publication.

AUSTRALIAN STANDARDS

Australian Standard	Definition
AS 1397:2021	Continuous hot-dip metallic coated steel sheet and strip — Coatings of zinc and zinc alloyed with aluminium and magnesium

FOR DETAILED PRODUCT INFORMATION,
MANUALS AND PROJECT CASE STUDIES VISIT:

LYSAGHT.COM

GALVSPAN®, LYSAGHT® and ® product names are registered trademarks of BlueScope Steel Limited and ™ product names are trademarks of BlueScope Steel Limited. © 2025 BlueScope Steel Limited. ABN 16 000 011 058. All rights reserved

INSPIRATION TO BUILD BETTER

