

ZENITH[®] ROOFING & WALLING

LYSAGHT

DESIGN & INSTALLATION MANUAL
CYCLONIC



INSPIRATION TO BUILD BETTER

AUSTRALIAN STANDARDS

Australian Standard	Definition
AS 1397:2021	Continuous hot dip metallic coated steel sheet and strip – Coatings of zinc alloyed with aluminium and magnesium
AS 3566.1:2002	Self-drilling screws for the building and construction industries Part1: General requirements and mechanical properties
AS 4040.0-1992	Methods of testing sheet roof and wall cladding
AS 4040.1-1992 (Reconfirmed 2016)	Methods of testing sheet roof and wall cladding - Method 1: Resistance to concentrated loads
AS 4040.2-1992 (Reconfirmed 2016, Amendment 1:2018)	Methods of testing sheet roof and wall cladding, Part 2: Resistance to wind pressures for non-cyclone regions
AS 4040.3:2018	Methods of testing sheet roof and wall cladding, Method 3: Resistance to wind pressures for cyclone regions
AS 4055:2021	Wind loads for housing
AS/NZS 1170.2:2021	Structural design actions, Part 2: Wind actions
AS/NZS 2728:2013	Prefinished/ pre-painted sheet metal products for interior/ exterior building applications – Performance requirements
AS/NZS 3500.3:2021	Plumbing and drainage Part 3: Stormwater drainage
SA HB 39:2015	Installation code for metal roof and wall cladding

Contents

1.0	Introduction & General Notes	4	7.0	General care, safety and handling	17
2.0	Design Preliminaries	7	7.1	Safety	17
2.1	Product selection	7	7.2	Care and storage before installation	17
2.2	Material and finishes	7	7.3	Handling cladding on site	17
2.3	Paint and COLORBOND® steel finishes	7	7.4	Walking on roofs	17
2.4	COLORBOND® steel with Thermatech® technology	7	7.5	Marking out, cutting and drilling	17
2.5	Impact resistance from wind-borne debris	7	7.6	General installation procedure	18
2.6	Maximum lengths of roofing	7	7.7	Clean up	19
2.7	Oil canning	8	7.8	Warn other contractors	19
2.8	Low roof pitches	8	7.9	Strippable coatings	19
2.9	Design criteria	8	7.10	Recommended sealants	19
2.10	Limit states wind pressures	8	7.11	Maintenance	20
2.11	Cyclonic testing procedures used for this manual	9	8.0	Ends of sheets	21
2.12	Wind forces on buildings	9	8.1	Turn-ups	21
2.13	Cyclonic areas & non-cyclonic areas	10	8.2	Turning-down	21
2.14	Environmental conditions	10	8.3	Blocking off rib cavities	21
2.15	Metal and timber compatibility	10	8.4	End-lapping	21
3.0	Fasteners	12	8.5	Expansion	21
3.1	Materials for screws	12	9.0	Flashings	22
3.2	Materials for blind rivets	12	9.1	Transverse flashings	22
3.3	Materials for sealing washers	12	10.0	LONGLINE 305® wall cladding	23
3.4	Setting of screws	12	10.1	Material specifications	23
4.0	Curved & bent roofs	12	10.2	Typical installation details	24
4.1	Roofing shape options	12	10.3	Typical construction details	25
4.2	Capped bent ribbed roof	12	11.0	ENSEAM® cyclonic roof and wall cladding	42
4.3	Transverse curved walls	13	11.1	Material specifications	42
5.0	Insulation	14	11.2	Typical installation details	44
5.1	Heat control methods	14	11.3	Typical construction details	48
5.2	Condensation	15	12.0	SNAPSEAM™ cyclonic roof and wall cladding	73
5.3	Insulation materials	15	12.1	Material specifications	73
5.4	Insulation thickness	15	12.2	Typical installation details	75
6.0	Roof drainage	16	12.3	Typical construction details	77
6.1	Maximum roof lengths for drainage	16	13.0	DOMINION® wall cladding	102
			13.1	Material specifications	102
			13.2	Typical installation details	104
			13.3	Typical construction details	111

ZENITH® ROOFING & WALLING

1.0 Introduction & General Notes

LYSAGHT® steel cladding has long been a valuable design resource for Australian architects, providing, as it does, aesthetically appealing and versatile facades that bend, often literally, to their creative will and add exciting visual dimensions to their designs.

In the ZENITH® cyclonic cladding range, that design value has reached new heights with profiles that deliver bolder aesthetics than seen before, paired with the exceptional performance you have come to know and expect from LYSAGHT® steel products.

ZENITH®. A touch of Europe from Australia's trusted experience in steel.

The ZENITH® cyclonic range includes:

LONGLINE 305®

This striking cyclonic wall cladding features slender, high ribs and broad, flat pans that make a dramatic statement on any structure.

ENSEAM®

Broad flat pans and a lower, yet substantial rib combine to form yet another distinct visual dynamic in ENSEAM® cyclonic roof and wall cladding. While possessing clean and striking good looks, this profile also has an easy style that makes it a very versatile cladding solution for contemporary architectural designs.

DOMINION®

Whether used in long lengths running vertically or horizontally on a structure, or in shorter lengths to create a 'block-like' effect, DOMINION® cyclonic facade wall panel makes a strong and extremely stylish statement. With raised panels and recessed, 'express' joints, this profile conveys a sleek, contemporary character with a pleasing detail created by the shadowed 'channels'.

SNAPSEAM™

With the broad flat pans and distinctive ribs of ENSEAM®, SNAPSEAM™ offers greater flexibility for longer lengths and greater spanning capacity thanks to its clever concealed fix clips. These clips allow for enhanced thermal expansion and contraction and provide greater fixing security.

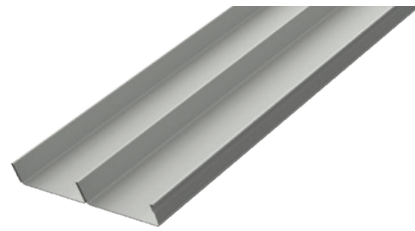

LONGLINE 305®

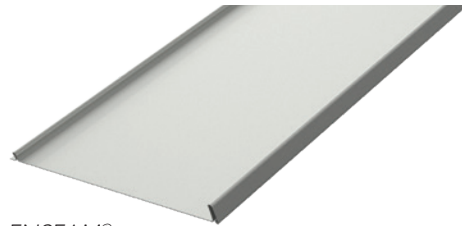

ENSEAM®



DOMINION®



SNAPSEAM™

IMPORTANT NOTE

The full ZENITH® cladding range comprises six (6) profiles. As detailed in this manual only four (4) of these profiles are recommended by Lysaght for use in cyclonic regions:

- **LONGLINE 305® - for walling applications only**
- **ENSEAM® - for roofing and walling applications**
- **DOMINION® - for walling applications only**
- **SNAPSEAM™ - for roofing and walling applications**

SCOPE

This manual is a guide to the design and installation of the ZENITH® cyclonic range of steel roofing and walling manufactured by Lysaght. We intend that it be used by all trades and professions involved with specifying and applying the ZENITH® cyclonic range of products.

We refer only to genuine steel roofing and walling manufactured by us and marketed under our brand names. Our recommendations should only be used for our products because they are based on comprehensive testing of our profiles, base metal thicknesses (BMT) and material finishes. More general design in installation with regard to steel cladding may be found in the LYSAGHT® Roofing and Walling Installation Manual. This manual covers a range of topics not covered in this manual.

WARRANTIES

For over 150 years we have consistently manufactured the highest quality building products. The LYSAGHT® brand is synonymous with Australian building.

Our continuing confidence in our products is shown in the warranties we offer.

Our products are engineered to perform according to our specifications only if they are used in the appropriate conditions and installed to the recommendations in this manual and our other publications.

Naturally, the warranties require specifiers and installers to exercise due care in how the products are applied and installed and are subject to final use and installation. Also, owners need to maintain the finished work.

We invite you to ask about the warranties applicable to your proposed purchase, at your supplier of LYSAGHT® products.

GENERAL NOTES TO READ BEFORE YOU USE THIS GUIDE

This Manual has been prepared for a range of the ZENITH® cyclonic range roofing and walling applications including water drainage systems, using products manufactured or supplied by Lysaght.

CYCLONIC AREAS

This book refers to cyclonic conditions. Design information for non-cyclonic areas is in our ZENITH® Design & Installation Manual. The information in this manual is suitable for use only in areas where a tropical cyclone is likely to occur as defined in AS/NZS 1170.2: Structural Actions - Wind Actions.

PROFESSIONAL ADVICE

All erection and connection details are to be made in accordance with the relevant standard connection detail drawings contained in this Manual.

We recommend you get professional advice to ensure your particular needs are adequately met.

To ensure maximum lifespan of your building, consult your nearest Lysaght branch for information regarding maintenance, handling, storage and any other technical assistance you may require.

FURTHER INFORMATION ON PRODUCTS AND SERVICES

WWW.LYSAGHT.COM

Your supplier of LYSAGHT® products

LYSAGHT® Information Service on 1800 641 417

CONDITIONS OF USE

If you use this Manual, you acknowledge and agree that your use is subject to the terms and conditions in this Manual. Lysaght, its agents, officers, employees, sub-contractors or consultants make no representations, either expressed or implied, as to the suitability of the information and data in this Manual for your particular purposes. It's your responsibility to ensure the design you use is appropriate for your needs, the products you have purchased, your site and structural limitations and your building and construction capabilities.

This Manual endeavours to present information on products, details, installation and practices in a clearly prescribed manner and it is the user's responsibility to apply the information in the way intended. If there is any uncertainty then it is the user's responsibility to seek clarification.

Where we recommend use of third party materials, ensure you check the qualities and capabilities of those products with the relevant manufacturer before use.

USE OF GENUINE MATERIALS

Structures in this Manual should only be built or constructed using genuine LYSAGHT® or recommended third party products. Except as otherwise provided in these terms, any warranties only apply to you (if at all) if you use the recommended genuine LYSAGHT® or third party products and method of construction.

CHECK DELIVERY

It is important that you check all materials delivered to site against your invoice before you use them in your building or construction to ensure all components have arrived, are of the appropriate quality and are ready for installation.



Contemporary and traditional, residential or commercial: all are accomplished with ease using ZENITH® steel cladding.



2.0 Design Preliminaries

2.1 PRODUCT SELECTION

When you design ZENITH® cladding into your building you have a range of profiles from which to choose. Whilst roofing and walling obviously have to keep out the weather, they also have significant effects on the looks, cost and durability of a building.

If you are unsure about any product feature, visit www.lysaght.com, call our information line or seek advice from the relevant specialists.

WALLS

The design of walling from a steel perspective is fairly straightforward. Once you have made the aesthetic decision of which profile to use, the main considerations are spans, capacities and fixing details and the details of flashings.

ROOFS

There are many factors in designing roofs including:

- the shape: is the roof to be 'flat' or pitched or curved?
- the supporting structure and support spacing;
- the wind forces that the roof must sustain;
- the pitch which affects the looks, the profile's ability to efficiently carry rain to the gutters, and fixing details;
- thermal expansion of long sheets (Chapter 8);
- the attributes of other materials used in the roof design.

This manual doesn't attempt to cover the structural design details of supports or aesthetics: there are many other texts and Australian Standards that cover them.

This manual provides tables for spans and capacities as well as the maximum roof length for pitch and rainfall intensity for ZENITH® cyclonic roofing products.

The appropriate design will depend on your particular needs and circumstances. You should get advice from the relevant specialists where required.

2.2 MATERIAL AND FINISHES

All of the ZENITH® range is manufactured from Australian made BlueScope steel.

MATERIAL SPECIFICATIONS

- Next generation ZINCALUME® aluminium/zinc/magnesium alloy coated steel complies with AS 1397 G300, AM125 (300 MPa minimum yield stress, 125g/m² minimum coating mass).
- COLORBOND® steel is pre-painted steel for exterior roofing and walling. It is the most widely used. The painting complies with AS/NZS 2728 and the steel base is an aluminium/zinc alloy-coated steel complying with AS 1397. Minimum yield strengths for the ZENITH® range is G300 (300 MPa). Minimum coating mass is AM100 (100g/m²).
- COLORBOND® Metallic steel is pre-painted steel for superior aesthetic qualities displaying a metallic sheen.
- COLORBOND® Ultra steel is pre-painted steel for severe coastal or industrial environments (generally within about 100m - 200m of the source). The painting complies with AS/NZS 2728 and the steel base is an aluminium/zinc alloy-coated steel complying with AS 1397. Minimum coating mass is AM150 (150g/m²).
- LYSAGHT PERMALITE® marine grade aluminium products are designed for severe coastal or industrial environments and are covered in separate documentation available on www.permalite.com.au or from your local Lysaght office.

2.3 PAINT AND COLORBOND® FINISHES

COLORBOND® steel finishes can be damaged by some handling, installation or maintenance activities. If damage occurs to the COLORBOND® steel pre-painted finish, refer to Technical Bulletin TB-2, published by BlueScope.

Replacement of severely damaged COLORBOND® steel should consider that the replacement sheet may not match perfectly due to the possible long term fading of the installed sheets exposed to weathering.

You may overpaint whole roofs and paint accessories to match specific colours. The overpaint guidelines are also discussed in Technical Bulletin TB-2.

ZENITH® is available in ZINCALUME® steel and a range of standard COLORBOND® steel, Ultra, Metallic and Matt colours. See www.lysaght.com for full colour range.

2.4 COLORBOND® STEEL WITH THERMATECH® TECHNOLOGY

COLORBOND® steel's core colour range in the Classic and Matt finish features our specially designed Thermatech® solar reflectance technology. Thermatech® reflects more of the sun's heat on hot, sunny days which may help increase your comfort while reducing your dependence on air conditioning. Thermatech® is available in all core colours except Night Sky®.

2.5 IMPACT RESISTANCE FROM WIND-BORNE DEBRIS

Parts of a building envelope (cladding, doors, windows) may be required to resist windborne debris according to AS/NZS 1170.2 and Technical Note No. 4, 'Simulated windborne debris impact testing of building envelope components', Cyclone Testing Station, James Cook University. These standards specify debris impact loading by timber member of 4kg mass with nominal cross-section of 100mm x 50mm and 8mm diameter spherical steel balls. ENSEAM® (roofing and walling), LONGLINE 305® (walling) and DOMINION® (walling) cyclonic assemblies have been evaluated to effectively resist cyclonic wind-borne debris for wind region C and D when used in conjunction with 19mm plywood or KF40 backing, refer to the relevant fixing requirements under each product.

2.6 MAXIMUM LENGTHS OF ROOFING

The valleys (or pans) of roofing have to carry water to the gutters. In heavy rain, the valleys overflow, water can flow into the roof through the side-laps and flashings.

Factors affecting waterproof and drainage capacity of the laps of a profile include:

- the width and depth of the valleys or pans;
- the pitch of the roof—rain flows faster on a steeper pitch;
- rainfall intensity for the geographical area;
- the length of the roof from ridge to gutter; and
- penetrations that cause nearby valleys to carry extra rain diverted from valleys obstructed by the penetration (Figure 6.1.1).

The maximum recommended roof lengths for drainage for each profile are given in Table 6.1.1.

An additional consideration for wide flat panned sheeting profiles is oil canning. To minimise the effect of oil canning it is recommended that sheet length be kept below 9m.

2.7 OIL CANNING

Architectural light gauge steel cladding products with wide flat surfaces may be subjected to oil canning. The oil canning feature can be defined as perceived waviness in the flat zone of a metal cladding when viewed at certain angles. The visual impact of oil canning is affected by the angle of light across the flat surface and this can be different at different times of the day and seasons.

Internal stresses within the metal can cause a waviness in the surface of the profile. There are many ways that the effects of oil canning can be minimised however due to the inherent nature of metal it can not necessarily be removed completely.

Some of the common causes of oil canning are;

PROFILE DIMENSIONS

The thinner the gauge of metal used and the wider the flat pan section of the profile the more evident oil canning will be. Conversely the thicker the material and the narrower the flat pan the less evident oil canning will be.

MANUFACTURING

The very nature of the manufacturing process of the profile can lead to oil canning. Any additional stresses put in the metal by way of shaping the metal or by slitting the coil can cause oil canning.

SUBSTRUCTURE

Any unevenness in the supporting substructure or any movement in the substructure will increase the effects of oil canning.

FIXING PLANE

The flat panned type cladding products when fixed to supports as specified in this publication will be structurally adequate. However, when used on walls and roof slopes that are visible by pedestrian traffic, these type of cladding products require consideration of the "in-service" aspect of aesthetics. The wall structure is commonly constructed to a different standard of construction tolerances and thus should not be relied upon as a suitable fixing plane.

Consequently, for aesthetics, these type of products require a support system that is installed plumb, level (uniform) and square to provide a suitable fixing plane for the wall cladding/pane to minimise the potential of pan oil-canning from support plane irregularity, installer activity and from thermal effect. Consequently the batten supports must also be of suitable rigidity and thickness to ensure a straight edge and the batten packed appropriately to minimise deviation from the straight edge and the fixing plane. Consideration should be given to using a minimum of 1mm BMT batten material.

CONNECTION DETAILING

Taking care with the connection details of the profile will assist in the effects of the oil canning, as often uneven stresses at the fastening points will exacerbate the oil canning effect. By allowing for expansion and contraction of the material the effects of oil canning will be minimised. This can be done by utilising by slotted holes sliding brackets and thermal breaks. It is important that if you are not familiar with detailing products that are prone to oil canning that you discuss with your local Lysaght representative ways to minimise the effects.

MATERIAL FINISH

The colour and finish of the material chosen will also effect the oil canning in the profile. Profiles of a dark colour make oil canning more obvious to the eye, as well as increasing the solar absorption of the material the thermal expansion and contraction of the material will also increase. The surface finish, i.e. a gloss or matt finish, will also affect the appearance of the oil canning. The higher the gloss finish the more the obvious the oil canning will be to the eye.

WEATHER

The weather plays a major role in the appearance of oil canning. The change in temperature on the surface of the profile will impact on the thermal expansion of the profile. Even though there may not be a large temperature difference in the ambient temperature there can be significant differences in temperature on the surface of the metal. A profile may be subjected to early morning frost, but by being positioned in full sun the surface temperatures can easily reach over 50°C during the day. There are many factors that can adjust the temperature experienced by the profile from the colour of the profile to location, orientation and shielding.

LIGHT

Light will impact on how noticeable oil canning is. Some days and times of day the oil canning may be more noticeable than others. The orientation that the light is reflecting off the waviness of the oil canning effects the way it is perceived by the eye.

HANDLING & STORAGE

Due care needs to be taken with all profiles especially those with large flat pans. Any additional stress put on the material will increase the likelihood of oil canning appearing in the pans. Oil canning is generally an aesthetic issue and structural integrity is typically not affected. In the absence of specific contract requirements oil canning should not be the sole grounds for panel rejection.

See Lysaght Product Advisory Bulletin PAB05 for more details on the subject of oil canning in metallic sheets.

2.8 LOW ROOF PITCHES

Unless there is adequate positive fall in a roof, there is danger of ponding, which can lead to a reduced service life, or reduced rainwater capacity. Reduced service life is of particular importance in more severe environments.

Roof slopes lower than the recommended minimum may be available subject to enquiry and will be dependent upon the roof application and building details. Lower roof slopes may require additional provisions to be adhered to. Please call your nearest service centre for advice.

2.9 DESIGN CRITERIA

The ZENITH® cladding system is designed based on the criteria of the following Australian standards and industries guide:

- AS/NZS 1170.2 Structural design actions, Part 2: Wind actions
- AS 1562.1 Design and installation of sheet roof and wall cladding – Part 1: metal
- AS 4040.0 Methods of testing sheet roof and wall cladding
- AS 4040.1 Methods of testing sheet roof and wall cladding - Method 1: Resistance to concentrated loads
- AS 4040.2 Methods of testing sheet roof and wall cladding, Part 2: Resistance to wind pressures for non-cyclone regions
- AS 4040.3 Methods of testing sheet roof and wall cladding, Method 3: Resistance to wind pressures for cyclone regions
- AS 4055 Wind Loads For Housing
- SA HB 39 Installation code for metal roof and wall cladding
- NCC 2019 Building codes of Australia

2.10 LIMIT STATES WIND PRESSURES

The ZENITH® range offers the full benefits of the latest methods for modelling wind pressures. The Wind Pressure capacities are determined by full scale tests conducted at Lysaght's NATA-registered testing laboratory, using the direct pressure-testing rig.

Testing was conducted in accordance with AS 1562.1 for general compliance, AS 4040.1 for resistance to concentrated load, AS 4040.2 for resistance to non-cyclonic wind pressures, AS 4040.3 for cyclonic wind pressures and NCC 2019 Building codes of Australia. The pressure capacities for serviceability are based on a deflection limit of $(\text{span}/120) + (\text{maximum fastener pitch}/30)$. The pressure capacities for strength have been determined by testing the cladding to failure (ultimate capacity). These pressures are applicable when the cladding is fixed to specified minimum supporting member or above.

2.11 CYCLONIC TESTING PROCEDURES USED FOR THIS MANUAL

The information in this document includes cyclonic capacities for the ZENITH® range of cyclonic claddings.

These capacities are derived from extensive full scale cyclonic tests conducted at Lysaght's NATA-accredited materials science testing laboratory.

CYCLONIC PRESSURE SEQUENCE IN CYCLONIC AREAS

The National Construction Code of Australia (NCC) requires all roof claddings, fixing connections and immediate supporting members to withstand a low-high-low (LHL) cyclonic testing regime. Similarly, Australian Standard AS 4040.3 requires all wall claddings, fixing connections and immediate supporting members to withstand a low-high pressure testing sequence.

Lysaght Research & Technology has performed comprehensive full scale tests of the ZENITH® range of claddings. These tests were conducted on our direct air pressure rig in our testing laboratory.

TYPES OF FAILURES

Our extensive testing has revealed that metal claddings and their supports can be subject to fatigue failure. When design is based on values within the published capacity tables, failure due to fatigue will not occur, as our tests are performed according to the cyclonic regime.

Non-Lysaght products cannot be substituted using these test values. Because our products have been subjected to full scale cyclonic testing, you can rely on the performance data we supply for genuine LYSAGHT® products. Substituting non-Lysaght products using these test values could cause failure due to fatigue.

Figure 2.11.1

Low-high-low testing for roof cladding.

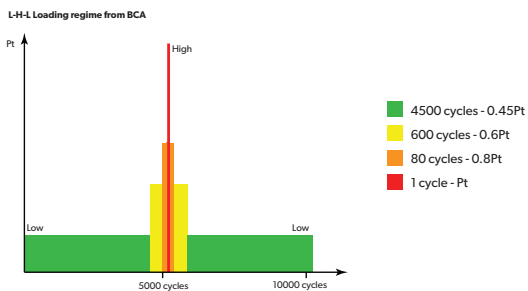

The sequence L-H-L loading regime is shown in the graph above where Pt is the ultimate limit state wind pressure.

AS 4040.3 2018 loading sequence for wall cladding systems

8000 cycles – 0.4 Pt	2000 cycles – 0.5 Pt	200 cycles – 0.65 Pt	1 cycle – 1.3 Pt
----------------------	----------------------	----------------------	------------------

Figure 2.11.2

Direct Air Pressure test rig showing cladding failure.

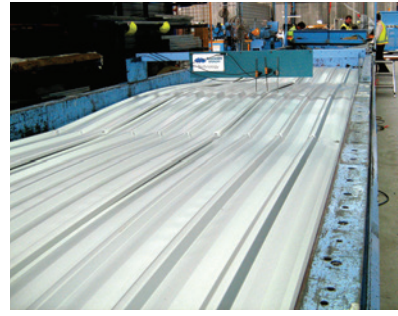

2.12 WIND FORCES ON BUILDINGS

Winds create considerable forces on both the outside and the inside of cladding, and you must consider these forces in the design and fixing of any roof. The forces are:

- **inward forces** tending to collapse the roof cladding inwards, caused by wind acting directly on the windward side; and
- **outward forces** tending to lift the roof cladding from its framing, and the entire roof structure from the rest of the building. Outward forces can be caused both by uplift from negative wind pressures, outside the building; and by positive wind pressure inside the building.

Generally the greatest wind forces imposed on roofs and walls are due to the outward forces. Because the dead weight of cladding is relatively small, the outward forces must be resisted by the fasteners.

It is very important that the battens and framing are adequately fixed to the rafters and walls, and that under extreme conditions the wall framing is anchored to the footings. Special anchoring provisions may apply in cyclonic areas. Specialist advice should be sought in these circumstances.

Figure 2.12.1:

Span types for Roofing and Walling

Roofing & Walling Profiles

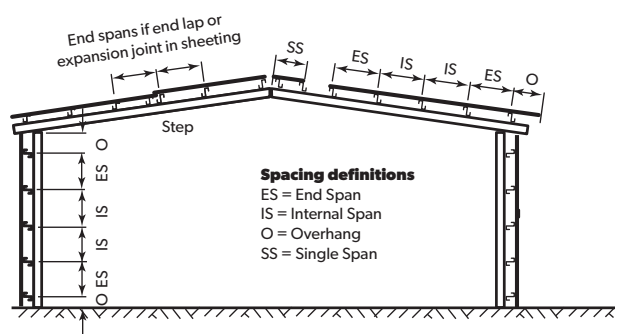

Walling Profiles Only

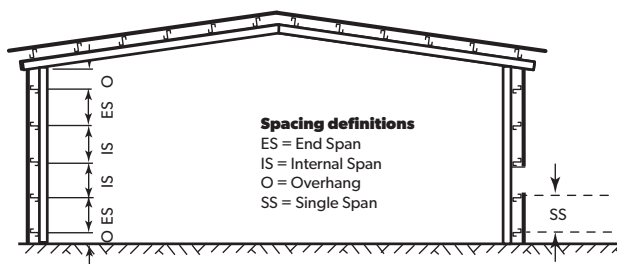

2.13 CYCLONIC AREAS & NON-CYCLONIC AREAS

Non-cyclonic areas and cyclonic areas of Australia are defined and detailed in AS/NZS 1170.2 and AS 4055.

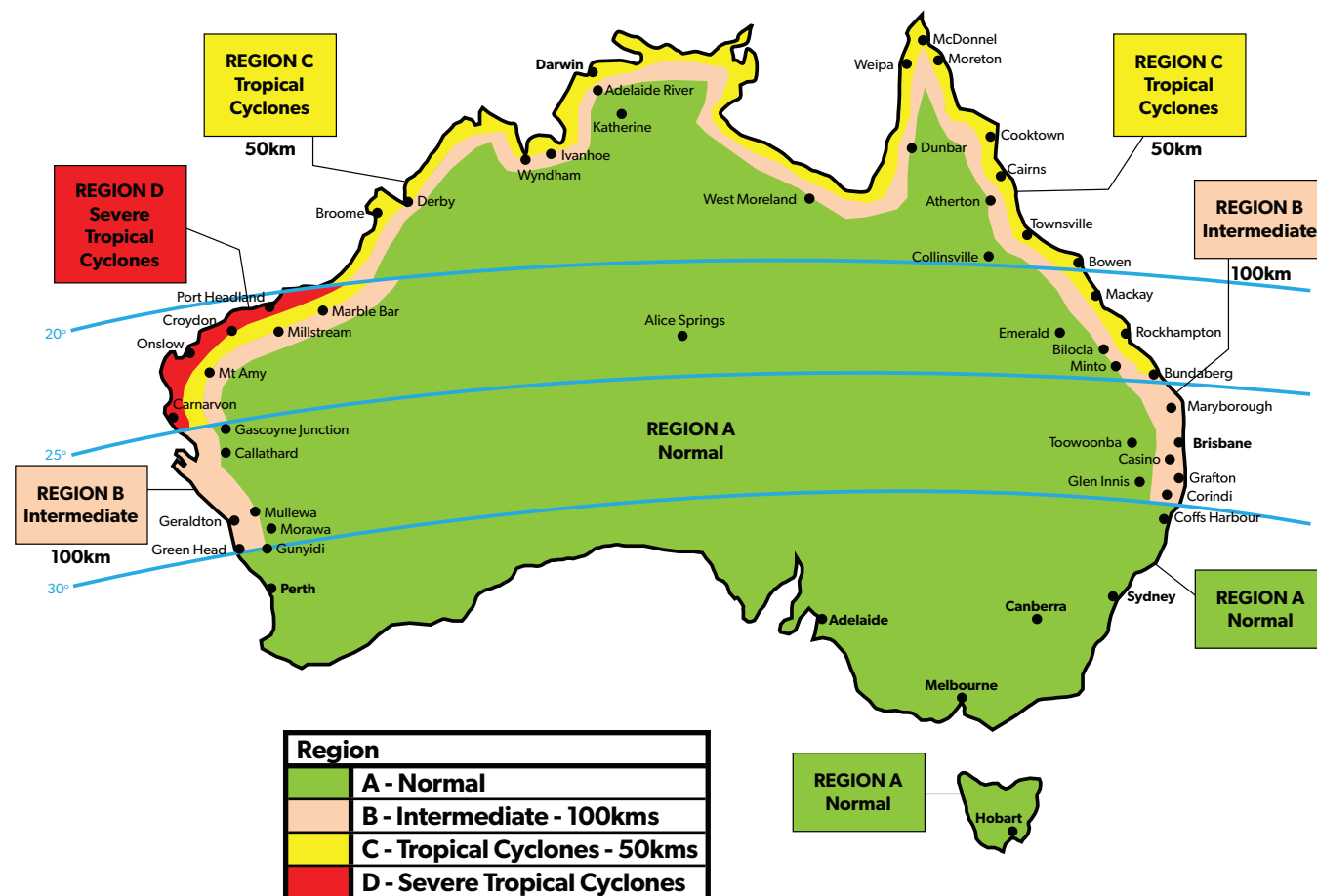

2.14 ENVIRONMENTAL CONDITIONS

Coated steel products can be damaged by some environmental conditions including industrial, agricultural, marine, intensive animal farming, swimming pools or other aggressive conditions. If any of our products are to be used in these conditions, or unusually corrosive environments, seek advice from your local Lysaght branch.

Keep the product dry and clear of the ground. If stacked or bundled product becomes wet for extended periods, separate it, wipe it with a clean cloth and stack it to dry thoroughly.

2.15 METAL AND TIMBER COMPATIBILITY

Contact with (or run-off from) some materials can damage coated steel products. Buildings can also be susceptible to condensation on inside surfaces.

The materials include certain metals, treated timbers and chemicals.

- Don't allow any contact of coated steel products with incompatible materials. (Table 2.15.1).
- Don't allow discharge of rainwater from incompatible materials onto coated steel products. (Table 2.15.1).
- Ensure that supporting members are compatible with the coated steel products or, alternatively, appropriately coated.

If there are doubts about the compatibility of other products being used, seek advice from our information line.

Incompatible materials include:

- lead
- copper
- monel metal
- bare steel
- stainless steel (except with SUPERDURA® Stainless steel cladding)
- carbon (in pencils and some rubbers)
- green or some chemically-treated timber (like CCA or tanalith treatments)
- materials subject to cycles of dryness and wetness or which have excessive moisture content (such as improperly-seasoned timber)
- wet and dry concrete
- soils
- vegetable matter
- cleaning agents (e.g. brick cleaning)
- any material which will inhibit normal exposure to the atmosphere

Table 2.15.1:

Acceptability of drainage from upper surface onto a lower metal surface and direct contact.

COMPATIBILITY OF DIRECT CONTACT BETWEEN METALS OR ALLOYS

ROOF DRAINAGE SYSTEM COMPONENTS & ANY CLADDING MATERIAL	ACCESSORIES OR FASTENER OR (UPPER SURFACE)								
	ZINCALUME® STEEL	GALVANISED (ZINC COATED STEEL)	ZINC	COLORBOND® STEEL, COLORBOND® ULTRA STEEL, COLORBOND® METALLIC STEEL	SUPERDURA® STAINLESS STEEL	STAINLESS STEEL	ALUMINIUM ALLOYS	COPPER & COPPER ALLOYS ⁽¹⁾	LEAD
ZINCALUME® STEEL	YES	YES	YES	YES	NO	NO	YES	NO	NO
GALVANISED (ZINC COATED STEEL)	YES	YES	YES	YES	NO	NO	YES	NO	NO
ZINC	YES	YES	YES	YES	NO	NO	YES	NO	NO
COLORBOND® STEEL, COLORBOND® ULTRA STEEL, COLORBOND® METALLIC STEEL	YES	YES	YES	YES	NO	NO	YES	NO	NO
SUPERDURA® STAINLESS STEEL	NO	NO	NO	NO	YES	YES	NO	NO	NO
STAINLESS STEEL	NO	NO	NO	NO	YES	YES	NO	NO	NO
ALUMINIUM ALLOYS	YES	YES	YES	YES	NO ⁽²⁾	NO ⁽²⁾	YES	NO	NO
COPPER & COPPER ALLOYS ⁽¹⁾	NO	NO	NO	NO	NO	NO	NO	YES	NO
LEAD	NO	NO	NO	NO	NO	NO	NO	YES	YES

⁽¹⁾ Monel - copper/nickel alloy.

⁽²⁾ For further guidance refer to AS/NZS 3500.3.

⁽³⁾ In benign environments, mixing of stainless steel and aluminium may be acceptable.

ACCEPTABILITY OF DRAINAGE FROM AN UPPER SURFACE TO A LOWER METAL SURFACE

LOWER ROOF DRAINAGE SYSTEM MATERIAL	ACCESSORIES OR FASTENER OR (UPPER SURFACE)									
	ZINCALUME® STEEL	GALVANISED (ZINC COATED STEEL)	ZINC	COLORBOND® STEEL, COLORBOND® ULTRA STEEL, COLORBOND® METALLIC STEEL	SUPERDURA® STAINLESS STEEL	STAINLESS STEEL	ALUMINIUM ALLOYS	COPPER & COPPER ALLOYS ⁽¹⁾	LEAD	GLAZED ROOF TILES, GLASS & PLASTIC
ZINCALUME® STEEL	YES	YES	YES	YES	YES	YES	YES	NO	NO	YES
GALVANISED (ZINC COATED STEEL)	NO	YES	YES	NO	NO	NO	NO	NO	YES	NO
ZINC	NO	YES	YES	NO	NO	NO	NO	NO	YES	NO
COLORBOND® STEEL, COLORBOND® ULTRA STEEL, COLORBOND® METALLIC STEEL	YES	YES	YES	YES	YES	YES	YES	NO	NO	YES
SUPERDURA® STAINLESS STEEL	YES	YES	YES	YES	YES	YES	YES	YES	YES	YES
STAINLESS STEEL	YES	YES	YES	YES	YES	YES	YES	YES	YES	YES
ALUMINIUM ALLOYS	YES	YES	YES	YES	YES	YES	YES	NO	NO	YES
COPPER & COPPER ALLOYS ⁽¹⁾	YES	YES	YES	YES	YES	YES	YES	YES	YES	YES
LEAD	YES	YES	YES	YES	YES	YES	YES	YES	YES	YES

⁽¹⁾ Monel - copper/nickel alloy.

⁽²⁾ For further guidance refer to AS/NZS 3500.3.

3.0 Fasteners

When you select fasteners, you should consider the design life of the structure, because the fasteners and the cladding material should have similar life expectancies.

3.1 MATERIALS FOR SCREWS

Table 3.1.1:

Product	Appropriate Screw Materials
For most external applications not closer than 400m from the ocean or severe marine influence: <ul style="list-style-type: none"> COLORBOND® steel (incl. Metallic) ZINCALUME® AM125 steel 	AS 3566.1 Class 3
For severe exposure conditions: <ul style="list-style-type: none"> COLORBOND® steel (200m to 400m from marine environments) COLORBOND® Ultra steel (100m to 200m from marine environments) AM150 	AS 3566.1 Class 4 Where the colour match of fasteners is an overriding consideration, powder coated/painted fasteners may be used
For very severe exposure conditions: <ul style="list-style-type: none"> SUPERDURA® Stainless steel PERMALITE® Aluminium 	Stainless steel

Stainless steel fasteners are recommended for use only with SUPERDURA® Stainless steel and PERMALITE® Aluminium.

3.2 MATERIALS FOR BLIND RIVETS

For GALVABOND®, ZINCALUME® and COLORBOND® steels, use aluminium blind rivets. Blind rivets are used for fixing flashings, accessories and side-laps.

3.3 MATERIALS FOR SEALING WASHERS

Sealing washers under the heads of screws used to fasten COLORBOND® steel must be made from materials that don't have significant levels of conductive carbon black, particularly in marine environments. Use EPDM washers, not neoprene.

3.4 SETTING OF SCREWS

Fasteners with sealing washers should be tightened only until the washer is gripped firmly enough to provide a weathertight seal. The fasteners should not be over-tightened because this may split the sealing washer or deform the sheet, either of which could lead to water penetration. Take particular care when valley fixing because there is no flexibility with the sheet hard against its support. Take particular care to ensure the fastener is driven perpendicular to the sheeting to avoid deformation of the washer.

Figure 3.4.1:

It is important that you set screws correctly.



3.5 FASTENERS FOR PLY SUBSTRATE

When 19mm (roofing) or 15mm (walling) plywood substrates are utilised the plywood substrate should be fastened to the building subframe in accordance with plywood manufacturers recommendations for flooring ply. Screws shall comply with AS 3566.1 Class 3 as a minimum.

4.0 Curved & bent roofs

4.1 ROOFING SHAPE OPTIONS

Curved sheets can be used for both roofing and walling applications. Sheeting can be curved into either concave or convex shapes as required.

An excellent method of cladding low-slope gable roofs is to run continuous lengths of roofing from eave to eave, across the full width of the roof. This gives a particularly neat and attractive roof. It is also possible to spring-curve sheets into a concave shape.

4.2 CAPPED BENT RIBBED ROOF

Another method for roofs with a pitch outside the spring curving range is the capped bent ribbed roof.

Tray cladding can be used in continuous lengths from eave to eave by cutting the ribs and bending the pans at the ridgeline. The same process is used on Mansard roofs. BAROQUE® is the only product in the ZENITH® range not suitable for capped bent ribbed roof applications. Caps are fitted over the cut ribs, which open up when the pans are bent. Fitting the rib caps can be time-consuming and care must be taken with sealing to avoid any possibility of leakage.

The ribs must be cut squarely, with a metal cutting blade in a power saw, set to the depth of the rib minus 2mm. Steel caps are then manufactured and installed as shown in Figure 4.1.3.

A neutral-cure silicon sealant should be used.

Figure 4.1.1:

Calculation of radius.

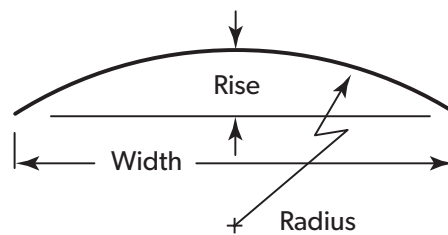

$$\text{Radius} = \frac{\text{Width}^2 + 4 (\text{Rise})^2}{8 \times \text{Rise}}$$

Figure 4.1.2:

Seal length for side-laps on spring-arched roof.

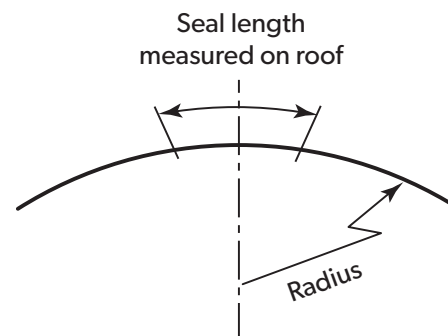

Seal Length

LONGLINE 305®

(minimum roof pitch 1°) = 0.035 x radius

IMPERIAL™ (325mm Cover)

(minimum roof pitch 1°) = 0.035 x radius

Figure 4.1.3:

Capped bent ribbed roof.

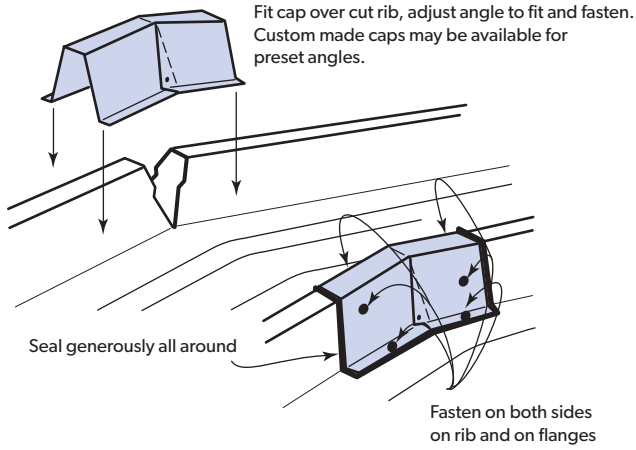

Figure 4.1.4:

Typical curved and bent applications.

Spring-curved-ridge roof

Sheets straight except for a curve near the ridge.



Spring-arched or convex roof

Sheets curved in a radius from eave to eave.



Spring-curved concave roof

Sheets curved concavely in a radius.



Pre-curved sheets

Sheets curved by machine before installation.



Capped bent ribbed roofs



Figure 4.1.5:

Spring-curved-ridge roof.

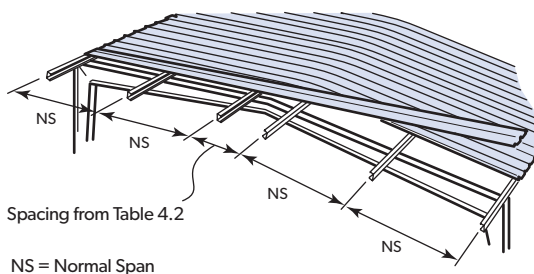

Figure 4.1.6:



Table 4.2:

Profile	Min Radii Transverse (Walling)	
	Transverse Spring Arched for (m) Convex/Concave	Max Support Spacing at Min Radius - Transverse Spring Curve (m)
ENSEAM®/ SNAPSEAM™	1.5**	Full ply support
DOMINION®	N/A	N/A

* Oil canning maybe an issue to be considered

** For Transverse Convex walling applications ENSEAM® and SNAPSEAM™ ribs should be pop riveted as per Figure 4.1.6 at max 500mm c/c

4.3 TRANSVERSE CURVED WALLS

Flat pan sheeting is readily adaptable to Transverse curving in walling applications for a subtle blended visual aesthetic. Min Transverse curve radii are outlined in Table 4.2. In transverse curved applications full ply support is required.

Figure 4.3.1:

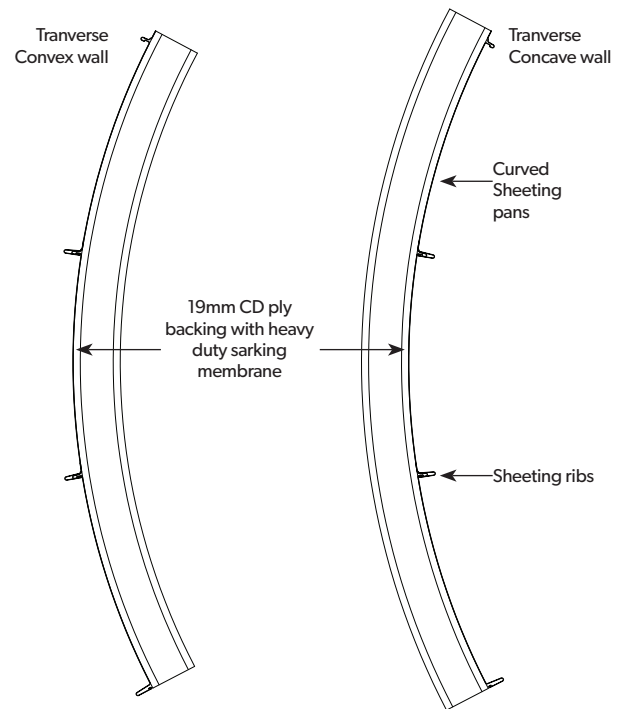

5.0 Insulation

5.1 HEAT CONTROL METHODS

In roofs, a simple, inexpensive and very effective method is to drape a membrane of reflective foil laminate over the supports before laying the cladding. The laminate can also provide a vapour barrier to minimise condensation. If the membrane is allowed to drape 50 to 75mm between the supports the air space between the membrane and the roof cladding will further improve heat insulation (Figure 5.1.2).

The ZENITH® range (with the exception of LONGLINE 305®) are designed to be installed in conjunction with a heavy duty roof sarking as an additional weather-proofing measure in both roofing and walling applications.

This sarking / blanket should be installed in accordance with the manufactures recommendations, sealed at the top, free from ripples and puckers, lapped and taped at joins. All laps in the sarking / blanket must be made with 150mm lap, sealed with double sided tape between the faces of the sarking and taped with sisal tape on the outside face.

Additional heat insulation is often achieved by using bulk insulation blankets or batts (Figure 5.1.3).

The same principles apply to walls, though the foil is not draped.

Figure 5.1.2:

Reflective foil laminate is simple, cheap and very effective.

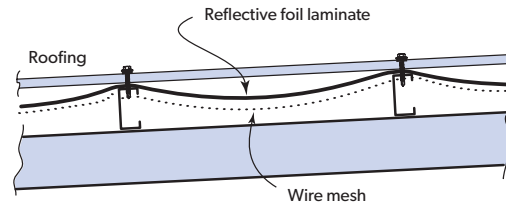

Figure 5.1.3:

Typical roof insulation with foil and blanket.

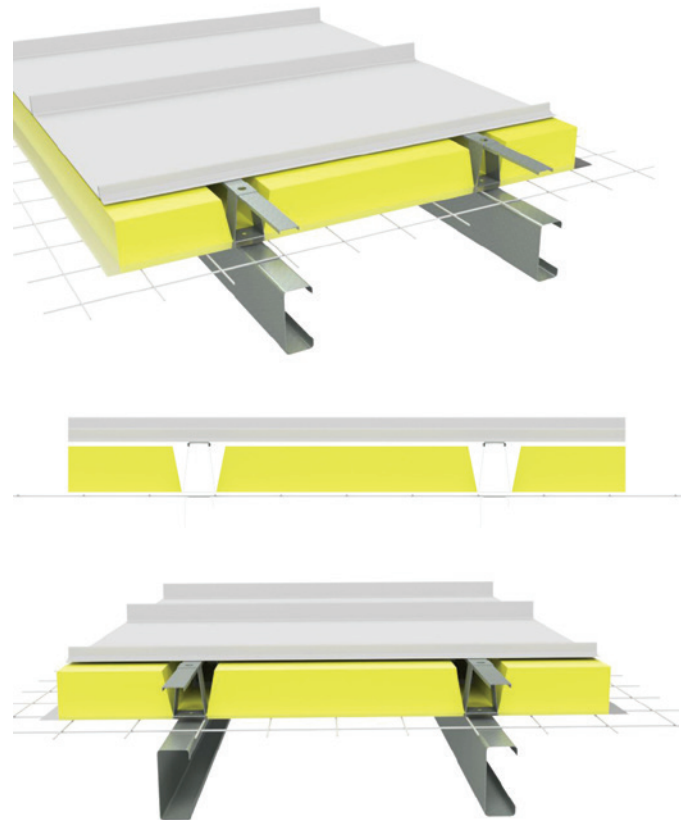

Table 5.1.1:

Approximate thermal transmission (for comparisons only).

	Roofing only		Roofing with reflective foil laminate		Roofing with 50mm insulation blanket & reflective foil laminate	
	Heat radiated from underside	Heat radiated + convected	Heat radiated from underside	Heat radiated + convected	Heat radiated from underside	Heat radiated + convected
	W/m ²	W/m ²	W/m ²	W/m ²	W/m ²	W/m ²
ZINCALUME® steel	25	40	2.0	9.0	2.0	7.0
COLORBOND® steel						
COOLMAX® (WHITEHAVEN®)	22.5	26.6	0.9	3.8	0.6	2.7
CLASSIC CREAM™, SURFMIST®	37.1	43.8	1.5	6.1	1.1	4.3
SANDBANK®	59.7	70.3	2.4	9.6	1.7	6.9
WILDERNESS®	91.2	106.9	3.6	14.4	2.5	10.3
WOODLAND GREY®	101.4	118.7	4.0	15.9	2.8	11.3
DEEP OCEAN®	108.2	126.6	4.3	16.9	3.0	12.0

Assumptions:

Solar radiation = 850 W/m² (average Australian summer), Ambient temperature = 30°C, Wind velocity over rood = 3m/s, Still air under the roof system, Inside temperature = 30°C.

5.2 CONDENSATION

When the air in a building in contact with metal cladding is warmer than the cladding, water vapour (moisture) in the air can condense on the inside of the cladding.

Water vapour passes fairly freely through most building linings into the ceiling and wall spaces where it may directly contact the cladding.

Condensation can lead to deterioration of building components and staining of ceiling and walls. If insulation blankets or batts are wet, or even slightly dampened by condensation, its efficiency is reduced markedly.

The amount of condensation depends upon the amount of water vapour in the air and this varies with climatic conditions. Activities within a building can add substantially to the amount of water vapour, and typical domestic situations include bathing, showering, cooking, washing and drying clothes and dishes, and breathing. It is essential to vent substantial amounts of water vapour to outside the building.

To minimise the risk of condensation on the underside of roofing, a Heavy Duty roof Sarking vapour barrier/waterproof membrane must be used for all ZENITH® installations prevent contact of warm moist air with the roofing.

To minimise the risk of condensation on the underside of the Heavy Duty Roof Sarking, the membrane must be slightly draped between roof supports so that the cold cladding is not in contact with the membrane (except at the supports).

Comprehensive guidance with regard to the location and type of membranes to be used with Lysaght roofing and walling products, including the Finesse range, may be found in the CONDENSATION CONTROL IN AUSTRALIAN BUILDINGS CONSTRUCTED WITH LYSAGHT® CLADDINGS document.

The CONDENSATION CONTROL document takes precedence over generalised membrane placement and types referenced in our Roofing and walling design manuals.

5.3 INSULATION MATERIALS

Typical insulation materials are reflective foil laminates, insulation blankets or batts made from fibreglass, and boards made from polystyrene. Remember that the colour of cladding also has a marked effect (Table 5.1.1).

FOIL LAMINATES

Foil laminates reflect heat and can double-up as a vapour barrier to control condensation. Where they are used as a vapour barrier the joints between successive strips are overlapped about 50mm, and sealed with a tape impervious to moisture.

BLANKETS AND BATTS

Blankets and batts minimise heat convection and are available with the laminate bonded to the fibreglass. They are also effective in reducing noise.

Insulation blankets must be protected from moisture, particularly around the edges of the roof and even more particularly at the bottom end of the cladding where rainwater run-off can be blown back under a low-pitched roof. If the blanket overhangs the bottom support, it may even come into contact with water in the gutter, where the insulation will absorb moisture and remain damp for extended periods, thus leading to deterioration of the coating on the underside of the roofing and reducing the effectiveness of the insulation.

5.4 INSULATION THICKNESS

Insulation blankets and batts can cause wide flat pan cladding to bow out between the supports, between fasteners along the support, or bow the pans. For insulation blankets and batts as well as more dense glass wool and rock wool, and thicker insulation, spacers are recommended.

Furthermore the cladding can bow when the blankets or batts are placed over taught safety wire. Taught safety wire prevents the insulation from draping between supports, thus compressing the insulation between the supports. This reduces the effectiveness of the insulation and also results in greater pressure placed under the cladding. Where the safety wire is taught then spacers are recommended to minimise these issues.

6.0 Roof drainage

6.1 MAXIMUM ROOF LENGTHS FOR DRAINAGE

Table 6.1.1:

Maximum roof lengths for drainage measured from ridge to gutter (m). Penetrations alter the flow of water on a roof. Thus, for design, you need to use an effective roof length (Figure 6.1.1).

	Peak Rainfall Intensity	Roof Slope					
		1 in 50* (1°)	1 in 30 (2°)	1 in 20 (3°)	1 in 12 (5°)	1 in 7.5 (7.5°)	1 in 6 (10°)
ENSEAM® 265mm cover	100		160	199	238	273	
	150		107	133	158	182	
	200		80	100	119	137	
	250		64	80	95	109	
	300		53	66	79	91	
	400		40	50	59	68	
SNAPSEAM™ 265mm cover	100		160	199	238	273	
	150		107	133	158	182	
	200		80	100	119	137	
	250		64	80	95	109	
	300		53	66	79	91	
	400		40	50	59	68	
	500		32	40	48	55	

Notes:

- Some lengths in this table may exceed the maximum allowable transport length.
 - Data are based on work of CSIRO and Lysaght.
 - For peak rainfall intensities in your locality, see Table 6.1.2 unless noted otherwise.
- For intermediate roof slope, use linear interpolation between values of the same category.

ENSEAM® Only: For roof pitch ≤ 3°, capillary action of rainwater in the laps of panels is more likely to happen.

Sheet lengths greater than 15m are not recommended due to thermal expansion and contraction.

Figure 6.1.1:

Example of calculating effective roof lengths where penetrations alter the flow of water on a roof.

Note: A suitably qualified engineer is recommended for calculating/checking roof design and flow design.

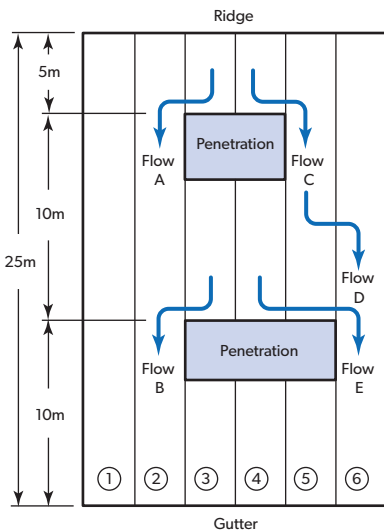

Valley	Effective Length
1	25m (Base Length)
2	Base Length + A + B 25 + 5 + 10 = 40m
6	Base Length + C + D + E 25 + 5 + 15 + 10 = 55m (Worst case used for design)

Table 6.1.2:

Design rainfall intensities.

	ARI once in 20 years mm/hr	ARI once in 100 years mm/hr
ACT		
Canberra	143	193
New South Wales		
Broken Hill	143	219
Sydney	200	262
Newcastle	226	316
Victoria		
Mildura	142	218
Melbourne	132	187
Ballarat	131	188
Queensland		
Brisbane	234	305
Rockhampton	229	300
Mackay	250	316
Mt. Isa	199	260
Townsville	235	300
Cairns	229	278
South Australia		
Mount Gambier	103	144
Adelaide	124	184
Western Australia		
Geraldton	138	193
Perth	130	172
Tasmania		
Hobart	85	116
Northern Territory		
Alice Springs	166	239
Darwin	233	274

Extract from NCC (2016)

7.0 General care, safety and handling

The following Section should be considered a guide only. For comprehensive information, building professionals should consult the appropriate legislation, regulations, codes of practice and technical literature such as SA HB 39 and LYSAGHT® technical bulletins.

7.1 SAFETY

It is commonsense to work safely, protecting yourself and workmates from accidents on the site. Safety includes the practices you use; as well as personal protection of eyes and skin from sunburn, and hearing from noise. Some sunscreens contain titanium oxides. These have been shown to break down some paint compounds and these should be avoided.

Occupational health and safety laws enforce safe working conditions in most locations. Laws in every state require you to have fall protection which may include safety mesh, personal harnesses and perimeter guardrails. We recommend that you are fully aware of all local codes of safe practice and you adhere strictly to all laws that apply to your site.

7.2 CARE AND STORAGE BEFORE INSTALLATION

Rain or condensation is easily drawn between the surfaces of stacked sheets by capillary action, or they can be driven in by wind. This trapped moisture cannot evaporate easily, so it can cause deterioration of the coating which may lead to reduced life-expectancy or poor appearance.

If materials are not required for immediate use, stack them neatly and clear of the ground and minimise the duration of exposure if left for extended periods. If left in the open, protect them with waterproof covers.

If stacked or bundled product becomes wet, separate it without delay, wipe it with a clean cloth and stack it to dry thoroughly.

7.3 HANDLING CLADDING ON SITE

On large building projects you can reduce handling time by lifting bundles with a crane direct from the delivery truck onto the roof frame. Use a spreader bar for long sheets. For small to medium size projects, without mechanical handling facilities, you can unload sheets by hand and pass them up to the roof one at a time.

Handling Safety - our product may be sharp and heavy.

It is recommended that heavy-duty cut-resistant gloves and appropriate manual handling techniques or a lifting plan be used when handling material.

Handle materials carefully to avoid damage: don't drag materials over rough surfaces or each other; carry tools, don't drag them; protect from swarf.

7.4 WALKING ON ROOFS

It is important that you walk on roofing carefully, to avoid damage to either the roofing or yourself.

If there will be heavy foot traffic or where an area is to be treated as non-trafficable on a roof, provide a temporary walkway or working platform with consideration of hand rails to minimise damage.

Always take particular care when walking on wet or newly laid sheets — particularly on steeply pitched roofs.

Always walk on or near the support lines this is usually the roof battens perpendicular to the ZENITH® panels. Walking in the pans,

keep your weight evenly distributed over the soles of both feet to avoid concentrating your weight on either heels or toes. Always wear smooth soft-soled shoes; avoid ribbed soles that pick up and hold small stones, swarf and other objects.

Great care should be taken when moving near roof overhang. The overhang should be treated as a non-trafficable area. When walking near an overhang, walk over or as close as practical to the roofing supports (usually over fastener locations).

For ZENITH® pan-type roofing walk in the pans, over supports, when you walk parallel to the ribs between supports

Be careful when moving between supports. Do not walk in the pan immediately adjacent to flashings or translucent sheeting. Walk at least one pan away.

When you walk across the ribs between supports, walk over or close to the roofing supports. (Usually over fastener locations).

7.5 MARKING OUT, CUTTING AND DRILLING MARKING OUT

A pencil of any colour may be used except black or so-called lead pencils. Don't use black pencils to mark roofing or walling because the graphite content can create an electric cell when wet and thus cause deterioration of the finish. You can also use a string line with chalk dust, or a fine, felt-tipped marker.

CUTTING

Where possible, you should minimise site-work by using sheets cut to length in the factory.

For cutting thin metal on site, we recommend that you use a power saw with a metal-cutting blade because it produces fewer damaging hot metal particles and leaves less resultant burr than does a carborundum disc.

Alternative cutting tools (electric shears and nibblers) are also suitable however extra care with the straightness of the cut may be required.

Cut materials over the ground and not over other materials where hot particles can fall and cause damage to finishes—especially COLORBOND® steel pre-painted finishes. It is best to have the exterior colour finish of a COLORBOND® steel pre-painted sheet facing down, however you must then protect the paint finish from scratching by your work supports.

If you have to cut materials near sheets already installed, mask them or direct the stream of hot particles away. Reciprocating nibblers are also widely used in the roofing trade, and they produce an excellent cut.

The resulting small, sharp scraps can rust and damage finishes; and they can cause personal injury. Take special care to collect these scraps.

SWARF

Sweep all metallic swarf and other debris from roof areas and gutters at the end of each day and at the completion of the installation. Failure to do so can lead to surface staining when the metal particles rust.

MAKING HOLES

Holes are often made by drilling or cutting by hole saw or jig saw. Mask the area around the hole to protect paint from damage by swarf.

7.6 GENERAL INSTALLATION PROCEDURE

CHECK FLATNESS, SLOPE AND OVERHANG

Before starting work ensure that:

- the supports for your cladding are truly in the same plane;
- the minimum roof slopes conform to Section 2.8 (Low roof pitches); and
- the overhangs of sheets from the top and bottom supports don't exceed recommendations, whilst also overhanging a nominal length into gutters.

Make any necessary adjustments before you start laying sheets, because they will be difficult or impossible to rectify later.

ORIENT SHEETS BEFORE LIFTING

Ensure that the sheets are orientated correctly – thus the outer/ weather surface of the sheets is pointed outward/upward/away from the supports.

ROOFING

Consider which end of the building is best to start from.

It is much easier and safer to turn sheets on the ground than up on the roof. Before lifting sheets on to the roof, check that they are the correct way up and the overlapping side is towards the edge of the roof from which installation will start.

Place bundles of sheets over or near firm supports, not at mid span of roof members.

Industry practice is for the sheets to start laying from the end of the building that will be in the lee of the prevailing weather wherever possible. This is more important when the roofing profile is more vulnerable (shallow profile, simple nesting of the side-laps, longer spans, shallow slopes, etc.) and when the vulnerable roof profile is in exposed situations. Deeper/stiffer roofing profiles and roofing profiles that interlock at the side-lap have considerably less reliance on laying direction.

WALLING

Generally wall sheets can be installed either vertically or horizontally.

Vertical installation is more common and the principles above for roofing can be applied.

Horizontal installation is carried out with the first sheet at the bottom with the overlap facing down. Following sheets are progressively installed up the wall.

POSITION FIRST SHEET

With particular care, position the first sheet before fixing to ensure that it is correctly located in relation to other parts of the building.

Check that the sheet:

- is aligned with the end-wall (or its barge or fascia), bearing in mind the type of flashing or capping treatment to be used; and
- aligns correctly at its ends in relation to the gutter and ridge (or parapet or transverse wall).

Fix the sheet as described later in this chapter.

POSITION OTHER SHEETS

After fixing the first sheet in position, align the following sheets using:

- the long edge of the previous sheet; and
- a measurement from the end of the sheet to the fascia or purlin at the gutter. It is important that you keep the gutter-end of all sheets in a straight line.

Fix the sheet by either:

- fixing each sheet completely, before laying the next; or
- fix the sheet sufficiently to ensure it can't move, complete laying all sheets, then return to place all the intermediate fasteners later.

CHECK ALIGNMENT OCCASIONALLY

Occasionally check that the sheets are still parallel with the first sheet, by taking two measurements across the width of the fixed cladding (Figure 7.6.2).

At about half way through the job, perform a similar check but take the measurements from the finishing line to aim for the final sheet to be parallel with the end of the roof. If the measurements are not close enough, lay subsequent sheets very slightly out of parallel to gradually correct the error by:

- properly align and fix a lap, then
- fix the other edge of the sheet, placing the fasteners slightly closer or further from where they would normally be if there was no error. (Gradually correct the error by placing the fasteners in such a way as to slowly bring the sheets back into correct alignment).

Figure 7.6.1:

Sheet lay direction when prevailing weather is a consideration.

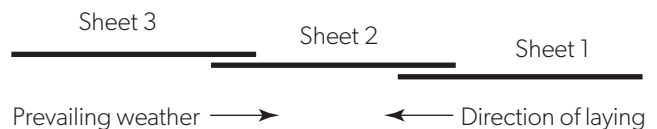
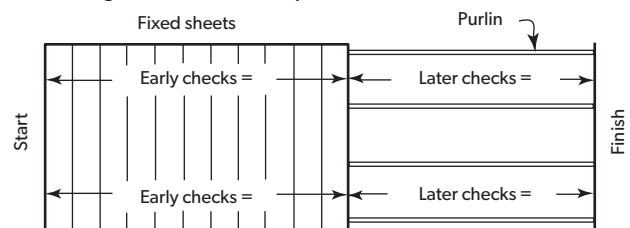

Figure 7.6.2:

Check alignment occasionally.



7.7 CLEAN UP

Swarf (metal scraps and/or abrasive particles resulting from cutting and drilling) left on the surfaces of materials will cause rust stains which can lead to reduced life of the material.

- Sweep or hose all metallic swarf and other debris from roof areas and gutters at the end of each day and at the completion of the installation. Failure to do so can lead to blockages of water flow or surface staining (such as when the metal particles rust).
- If swarf has become stuck on a finish, it can be removed. Take great care not to remove the paint or the metal coatings.
- For critical applications inspect the job two weeks after completion, when rain or condensation will have caused any remaining swarf to rust, and thus highlight affected areas.

7.8 WARN OTHER CONTRACTORS

Many stains arising from swarf do so, not from the work of roofing-installers, but from other contractors working on the job. Similarly, problems can arise from contact with incompatible materials, like copper piping or chemically treated timber. Acid cleaning of bricks can also be a problem. Remember to warn them to walk on pans, and over supports, not on the ribs. Architects and builders need to be aware of all this, and warn contractors accordingly.

7.9 STRIPPABLE COATINGS

To provide temporary protection during production, handling and transport, some COLORBOND® steel products are coated with a plastic. This coating peels off easily when new, but it has a relatively short life, especially in sunlight. If you don't remove this coating at the time of installation, you may find it very hard to remove later on.

Please dispose of the plastic in an environmentally responsible manner.

7.10 RECOMMENDED SEALANTS

Neutral-cure silicone sealants have been successfully used with the range of steel finishes on our roofing and walling; and on flashings, cappings, and gutters made from the same materials as the cladding.

Neutral-cure silicone sealants:

- have good adhesion to the clean surface of all our roofing and walling;
- are water resistant and non-corrosive;
- are resistant to extremes of heat and cold while retaining good flexibility;
- excellent gap fillers;
- provide high resistance to ultra-violet rays (sunlight); and
- have a long service life.
- they are NOT adhesives.

It is important that only neutral-cure silicone be used with sheet steel. Other silicone sealants, often have a vinegar or ammonia smell, and give off aggressive by-products during curing which are detrimental to sheet steel.

If in doubt, look for a message on the sealant package like: Suitable for use with galvanised and ZINCALUME® steel products.

CLEANING SURFACES

For effective bonding, all surfaces must be clean, dry and free from contaminants such as old sealant or oil.

Mineral turpentine is suitable for cleaning the surfaces but care must be taken to completely remove all residual solvent with a clean dry cloth. White spirits is an alternative.

Sealant must be applied on the same day as the surface is cleaned.

JOINT STRENGTH

Joints sealed with sealant should be mechanically fixed for strength. Spacing of the fixing will depend upon the type of joint to be sealed. Fasteners in joints of simple seams (flat sheet steel joints) should generally be no further apart than 50mm. Fasteners in joints with profiled roofing (e.g. side-lap joints) can be spaced further apart. The spacing of the fasteners shall be based on good and accepted industry practices to ensure suitable bonding of the sealant to the mating surfaces.

The sealant does not require significant adhesive strength in itself, but it must bond positively to all the surfaces it is to seal. To ensure complete sealant cure, the width of sealant in a lap should not exceed 25mm when compressed (Figure 7.10.1).

SEALED JOINTS

For sealed joints use screws or 4.8mm sealed blind rivets and neutral-cure silicone sealant branded as suitable for use with galvanised or ZINCALUME® steel.

APPLYING SEALANT

Always apply the bead of sealant in a continuous line along the centreline of the fastener holes. This ensures that, when compressed, the sealant positively seals the fastener.

Be careful not to entrap air when applying sealant. Especially, don't place a ring of sealant around fastener holes because entrapped air compresses during tightening of fasteners, and may blow a channel through the sealant, which could prevent the fastener from being sealed.

FASTENERS

Use solid or sealed fasteners (e.g. screws and blind pop rivets), otherwise you have to apply sealant to the hollow centre of open pop rivets.

To preserve the life of your cladding, is very important that fastener materials are compatible with the cladding (Section 2.15).

PROCEDURE

The preferred procedure for lap fabrication is:

1. Assemble, clamp and drill;
2. Separate components and remove drilling debris;
3. Clean joint surfaces as recommended above;
4. Apply bead(s) of sealant;
5. Relocate components and fix;
6. Externally seal each fastener if hollow blind rivets are used.

To prevent premature curing (which causes poor bonding), finish the joint as soon as practical after applying the beads of sealant. The manufacturer's specified sealant open times should be followed.

SEALANT CLEAN UP

With practice you will be able to judge the size of beads thus avoiding squeeze-out and the subsequent need to clean up.

Uncured sealant can be removed with a clean, dry rag and any excess then removed with a cloth lightly dampened with mineral turpentine or white spirits. Excess cured sealant is best removed with a plastic spatula to avoid damage to the surface finish of the metal.

Avoid any unnecessary smearing of sealant on surfaces intended for painting as silicone can affect adhesion of paint. Smearred sealant may be treated by lightly abrading the area with a non-metallic scouring medium.

Figure 7.10.1:

Typical joints with sealant.

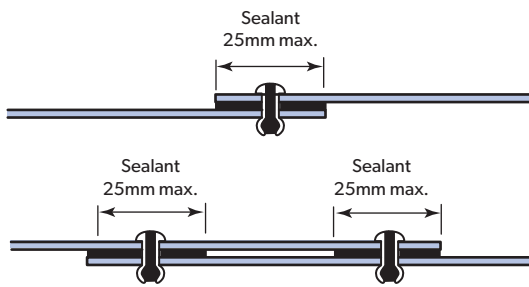

7.11 MAINTENANCE

Factors that most affect the long life of a roof (or wall) are original design, the environment of the installation, and the maintenance of the installation. Maintenance is probably the biggest factor.

Maintenance includes:

- Regular inspection for problems before they become major corrosion sites;
- Regular washing down, especially near coastal or industrial influences;
- Removal of leaves and other debris from gutters, downpipes, leaf-guards, slots, holes and other overflow devices;
- Keep walls free of soil, concrete and debris near the ground;
- Don't overspray pesticide.

MAINTENANCE OF COLORBOND® PRE-PAINTED STEEL

The paint system on COLORBOND® steel sheet is very durable. Simple maintenance of the finish enhances its life and maintains attractiveness for longer periods.

Where the paint finish is naturally washed by rainwater (roofs, for example) there is usually no additional maintenance needed. However areas to be washed include soffits, wall cladding under eaves, garage doors, and the underside of eave gutters.

Washing should be done at least every six months and more frequently in coastal areas where sea spray is prevalent, and in areas where high levels of industrial fallout occur. Avoid accumulation of salty deposits or industrial dirt.

Establish a regular routine for washing COLORBOND® pre-painted steel products. Often garage doors can be washed with clean water at the same time as your car is being washed. Guttering and eaves can be hosed down when windows are being cleaned. Walls can be hosed down (if water restrictions permit) while watering the garden.

Where regular maintenance doesn't remove all the dirt, wash the surface with a mild solution of pure soap or non-abrasive non-ionic kitchen detergent in warm water. Use a sponge, soft cloth or soft bristle nylon brush; be gentle to prevent shiny spots. Thoroughly rinse off the detergent with clean water.

Never use abrasive or solvent cleaners (like turps, petrol, kerosene and paint thinners) on COLORBOND® steel surfaces. For advice on grease, oil or deposits not removed by soap or detergent contact our Information Service.

8.0 Ends of sheets

This chapter describes how you can treat the ends of sheets to maximise weather resistance, environmental protection and vermin resistance.

8.1 TURN-UPS

At the high end of roofing, wind can drive water uphill, under the flashing or capping, into a building. To minimise this problem, you turn up the valleys (or pans) at the high end of roofing. (The process is called turning-up (or stop-ending).

All roofing on slopes below 1 in 2 (25°) should be turned-up.

During the turn-up operation, care should be exercised to prevent tearing or puncturing the steel sheets.

You can turn-up sheets before or after they are fixed on the roof. If you do the latter, you must have sufficient clearance for the turn-up tool at the top end of the sheets (about 50mm).

8.2 TURNING-DOWN

TURNING-DOWN TRAYS

When wide tray sheeting is used on roof slopes below 1 in 5 (10°) the end of the trays at the low end of the sheeting should be turned down slightly with a turn-down tool. At the low end of roofing, wind or capillary action can cause water to run back up the underside of the flat trays of the sheeting. The process is called turning-down (or lipping).

During the turn-down operation, care should be exercised to prevent tearing or puncturing the steel sheets.

Turning-down is usually done after the sheeting is fixed on the roof, provided there is no obstruction to the operation of the turn-down tool.

- Push the turn-down tool over the end of the tray, as far as it will go.
- Hold the tool hard against the end of the tray and push the handle to form a turn-down about 20°.

8.3 BLOCKING OFF RIB CAVITIES

Dust, insects, birds, rodents, bush fire embers and wind-driven rain and pollutants can enter a building through the cavities under ribs. To minimise these problems the cavities can be blocked off. The blocking off could be achieved by the use of infill strips, turn-down of ribs where possible or, where available, by rib stop-ends. Blocking off rib cavities may also assist with such problems in situations where roof slopes are installed at below the minimum recommended.

In severe environments blocking off of the ribs is recommended, especially with clip - fixed claddings, to protect the cladding fasteners and clips.

INFILL STRIPS

Closed-cell, foam-plastic infill strips are available to match our standard size claddings.

At the lower end of cladding, the strip is sandwiched under the roof cladding and on the lower side of the cladding to protect the fasteners/clips. Similarly, at the upper end, the strip is sandwiched between topside of the roofing and the underside of the flashing or capping.

Don't use infill strips that can absorb water because retained moisture can lead to deterioration of the sheet coating. Avoid using infill strips made from, or treated with, flammable materials, particularly in areas prone to bushfire.

Where roof pitches are below 1 in 5 (10°), you should incorporate infill strips to maximise resistance to water entry.

8.4 END-LAPPING

Because our roofing and walling is manufactured by continuous processes, sheet lengths can be supplied up to the limits of transport regulations which are frequently long enough to cover roofs without end-lapping the sheets. End-lapping on ENSEAM® is not recommended.

8.5 EXPANSION

BACKGROUND ON THERMAL EXPANSION

All metals expand and contract with changes in temperature. Although steel is by far the least affected of all the metals commonly used for roof and wall cladding, the changes in length experienced in very long runs of roofing are significant.

On a clear hot summer day, with no wind, the steel temperature in roof cladding can reach approximately 50°C in COLORBOND® steel in colour Surfmist®, 60°C in plain ZINCALUME® steel and more than 80°C in COLORBOND® steel in colour Night Sky®.

Examples of the thermal changes in lengths of steel cladding that would result from various temperature changes in the steel are shown in Table 8.5.1.

The actual expansion or contraction between the end of a sheet and the last support would only be a fraction of the figures shown because the movement in the length of fixed cladding would normally take place from the centre towards each end of the sheet. The movement at each end is thus only half the total expansion or contraction.

Transverse thermal expansion poses no problems in ribbed cladding because each rib absorbs some transverse movement.

Table 8.5.1:

Thermal expansion and contraction of steel cladding.

Sheet length (mm)	Expansion or contraction (mm)		
	10°C change	50°C change	75°C change
5000	0.6	3	4.5
10000	1.2	6	9
15000	1.8	9	13.5
20000	2.4	12	18
25000	3.0	15	22.5
30000	3.6	18	27

Table 8.5.2:

Maximum distance between top & bottom rows of fasteners on a sheet, before expansion joint is needed.

Fixing system	Maximum distance between top and bottom rows of fasteners (m)
Pierce-fixed through crests	24
Walling pierced-fixed in valleys/pans	15

9.0 Flashings

FLASHING COVER

The minimum recommended cover of longitudinal flashings over cladding should be as follows: (as taken from SA HB 39).

Pierce-fixed roof sheet	150mm min.
Concealed fixed roof sheet	Into full pan (2/3 pan covered)

9.1 TRANSVERSE FLASHINGS

FLASHING COVER

Lysaght are able to produce a wide range of custom flashings to suit your individual requirements. To increase weathertightness, Lysaght recommends you maximise the overlap between flashings and claddings.

FIXING OF FLASHINGS

Longitudinal flashings shall be fastened at maximum 500mm centres. Transverse flashings shall be fastened in accordance with SA HB 39, as detailed below.

Profile (min.)	Recommended Fixing Space
LONGLINE 305®, ENSEAM®, DOMINION®	Every rib

The above fastener spacing relates to the stitching of flashings to sheeting. It does not constitute the minimum number of fasteners required to fix the sheeting to purlins.

NOTCHING

Flashings can be notched to the rib profile with tinsnips (Figure 9.1.1). The procedure is sometimes known as scribing. After the cladding is fixed and the turn-ups finished, proceed as follows.

- Place the flashing with the turned-down edge resting on the ribs.
- Mark out the notching using a template positioned over each rib.
- Cut the notches with tinsnips.

This procedure is also used for hip cappings.

FASTENERS FOR TRANSVERSE FLASHINGS

You must properly fix both flashings and the ends of all sheets.

Where the cladding is pierce-fixed through crests, and the position of the purlin allows it, the fasteners used to fix the sheets, may also fix the flashings.

On all other installations, pierce-fix your flashing to the ribs or crests of the sheets.

Figure 9.1.1:

Using a template to mark out for notching with tinsnips.

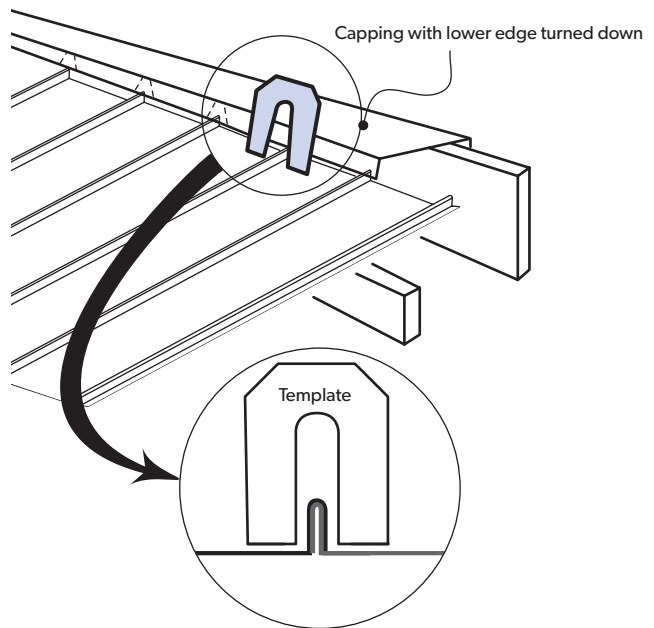
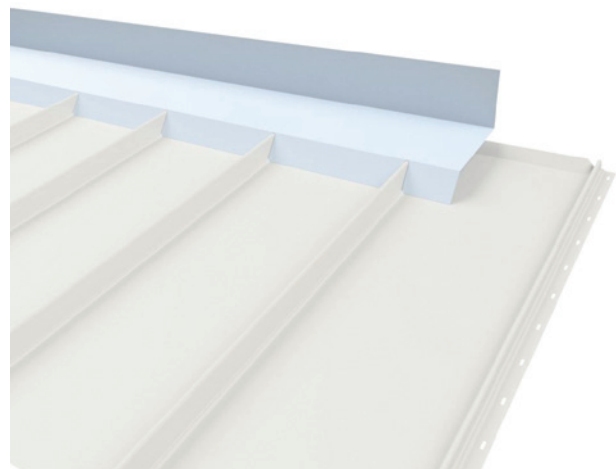

Figure 9.1.2:



10.0 LONGLINE 305® wall cladding

For cyclonic applications LONGLINE 305® cladding is a pierced fixed wall cladding with bold ribs and wide pans. It is ideal for medium to large commercial projects where special architectural effects are desired. It has also been popular in industrial and residential applications.

10.1 MATERIAL SPECIFICATIONS

Coverage (mm)	305
Base Metal Thickness (mm)	0.70
Total Coated Thickness⁽¹⁾ (mm)	0.75
Rib Height (mm)	48
Sheet Length (mm)	
Minimum	1200
Maximum	30000
Mass / Unit Length (kg/m)	
ZINCALUME® steel	2.96
COLORBOND® steel ⁽¹⁾	2.99
Mass / Unit Area (kg/m²)	
ZINCALUME® steel	9.70
COLORBOND® steel ⁽¹⁾	9.81
Minimum Yield Strength	300 (G300)
Coating Class (See Base Material for detail)	AM125 - ZINCALUME® steel AM100 - COLORBOND® steel AM100 - COLORBOND® Metallic steel AM150 - COLORBOND® Ultra steel
Tolerance	Sheet length: +0mm / -15mm Standard cover width: +4mm / -4mm
Thermal Expansion	2.9mm average per 5m @ 50°C change

Notes:

1. Based on standard, single sided COLORBOND® steel. For other painted steel options please contact your Lysaght representative.

MINIMUM ROOF PITCH

LONGLINE 305® cladding is not suitable for cyclonic roofing applications.

INSULATION

Care needs to be taken when installing insulation with LONGLINE 305® sheeting. The screws may need to be increased depending on the thickness and density of the insulation. When the screw is properly tightened into metal there should be a minimum of three (3) threads protruding past the support being fixed in to. For timber the screw must have a min embedment of 25mm into the timber.

For insulation, the use of spacing system is recommended to help maintain R_w values as well as minimising any bulging in the profile caused by the insulation. Refer to oil canning section for potential visual impacts of insulation on the product.

LONGLINE 305®: LIMIT STATE WIND PRESSURE CAPACITIES (KPA) 0.70MM BMT

Span Type	Span (mm)				
	600	900	1200	1500	1800
Single & End	6.85	5.55	4.45	3.55	2.80
Internal	7.45	6.30	5.25	4.35	3.60

*Support must be ≥1.5mm BMT. Capacity is based on tests with no insulation under the sheeting.

Figure 10.1.1:

LONGLINE 305® profile.

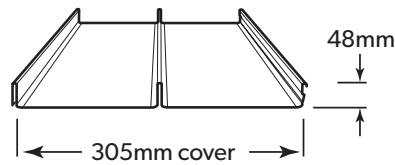

FASTENING LONGLINE 305® CLADDING TO SUPPORTS

LONGLINE 305® cladding is pierced-fixed to supports.

Table 10.1.1:

Fasteners Without Insulation.

	Fix to Steel Single steel thickness >1.5mm BMT up to 3.0mm BMT	Fix to Timber Hardwood or 19mm plywood J1-J3	Fix to Timber Softwood J4
Pierced Fixed	14-10x25mm, Metal Tek's. Hex head with EPDM sealing washer	14-10x25, Type 17, Hex head with EPDM sealing washer	14-10x25 Pierce fixed, Type 17, Hex head with EPDM sealing washer

Notes:

1. For other steel thicknesses not specified please seek advice from screw manufacturer
2. As above or equivalent fastener

Table 10.1.2:

Guide to estimate fasteners and clips required for typical installation.

FASTENER REQUIREMENT

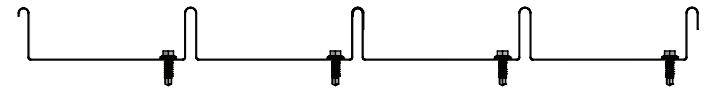

1 screw adjacent to rib.

Buildex #14-10x25mm Metal Tek's® Hex Head with EPDM sealing washer.

Table 10.1.3:

Guide sheet coverage.

SHEET COVERAGE

Width of Roof (m)	3	4	5	6	7	8	9	10	11	12	13	14	15	16	17	18	19	20	30	40	50
Number of Sheets	10	14	17	20	23	27	30	33	37	40	43	46	50	53	56	60	63	66	99	132	164

WIDTH COVERED BY 'X' NUMBERS OF SHEETS (M)

Number of Sheets	3	4	5	6	7	8	9	10	11	12	13	14	15	16	17	18	19	20
Coverage (m)	0.9	1.2	1.5	1.8	2.1	2.4	2.7	3.1	3.4	3.7	4.0	4.3	4.6	4.9	5.2	5.5	5.8	6.1

10.2 TYPICAL INSTALLATION DETAILS

INSTALLING LONGLINE 305®

For LONGLINE 305® use the same general procedure described in Section 7.6 (General installation procedure).

PREPARATION

Before starting, check that the supports on which your sheeting will rest are in the same plane; that the pitch and overhangs conform to the minimum specifications.

ORIENT SHEETS BEFORE LIFTING

Consider which end of the building is best to start from. So that side-laps are protected, we recommend that you start laying sheets from the end of the building that will be in the lee of the worst anticipated or prevailing weather.

It is much easier and safer to turn sheets on the ground than up on scaffolding etc. Before lifting sheets on to the wall, check that they are the correct way up and the overlapping side is towards the edge of the roof from which installation will start.

FIX THE FIRST SHEET

With particular care, determine the location of the first sheet and mark the edge of the sheet on the wall girts.

Fix the first sheet on the girt. The first sheet will need 2 fixing screws in the pan. 1 at each rib.

FIX THE NEXT SHEETS

1. Place the next sheet over the edge of the preceding sheet. Accurately position the sheet so that it overhangs the desired amount into the gutter.
2. Fully engage the sheet and screw fix.

CHECK ALIGNMENT PERIODICALLY

Check that sheets are still parallel with the first sheet.

PLACE THE LAST SHEET

Assess how the last sheet will fit in relation to the building corner.

Figure 10.2:

Fixing LONGLINE 305® with KF40 support for applications where resistance to Wind borne debris is required to AS/NZS 1170.2.

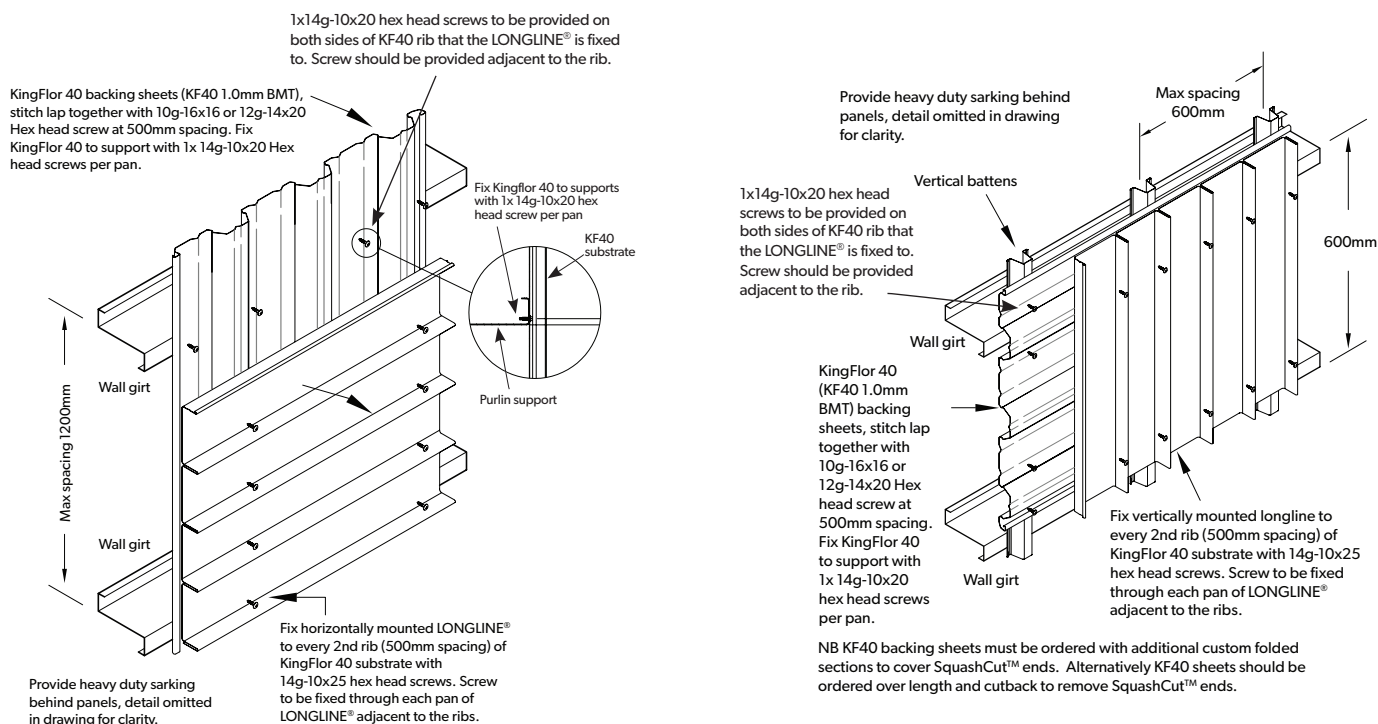

10.3 TYPICAL CONSTRUCTION DETAILS LONGLINE 305®

The construction details presented here represent potential detailing solutions to common construction situations. These details may not be suitable for all projects / situations and users should use professional judgement in determining suitability of the details for their particular project whilst referencing AS 1562.1 and SA HB39. The full suite of ZENITH® constructions details are available for download from <https://bimcontent.com/lysaght/> in both REVIT and PDF format.

10.3.1 LONGLINE 305® TYPICAL WALL DETAILS - HORIZONTAL FIX

Figure 10.3.1.1:

Typical Wall Cladding Setout - Unsupported LONGLINE 305® Panel - Horizontal Fix - Plan View - L04-01

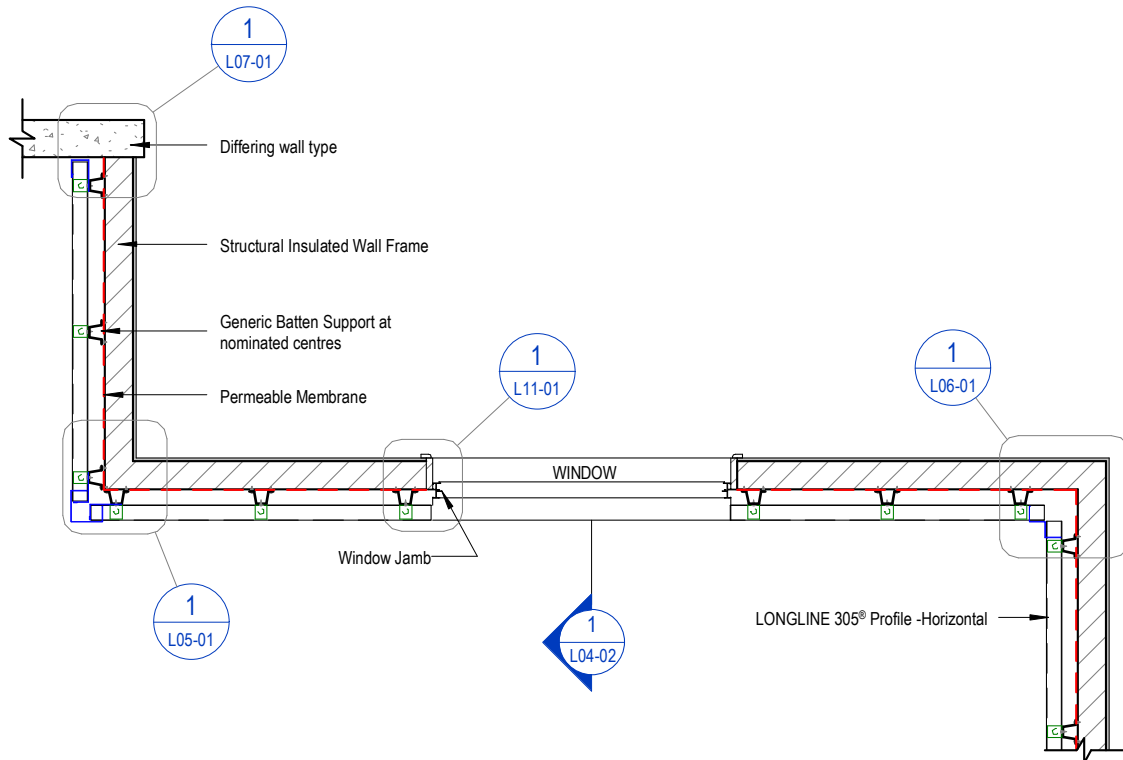

Figure 10.3.1.2:

Typical Wall Cladding Setout - Unsupported LONGLINE 305® - Horizontal Fix - Sectional View - L04-02

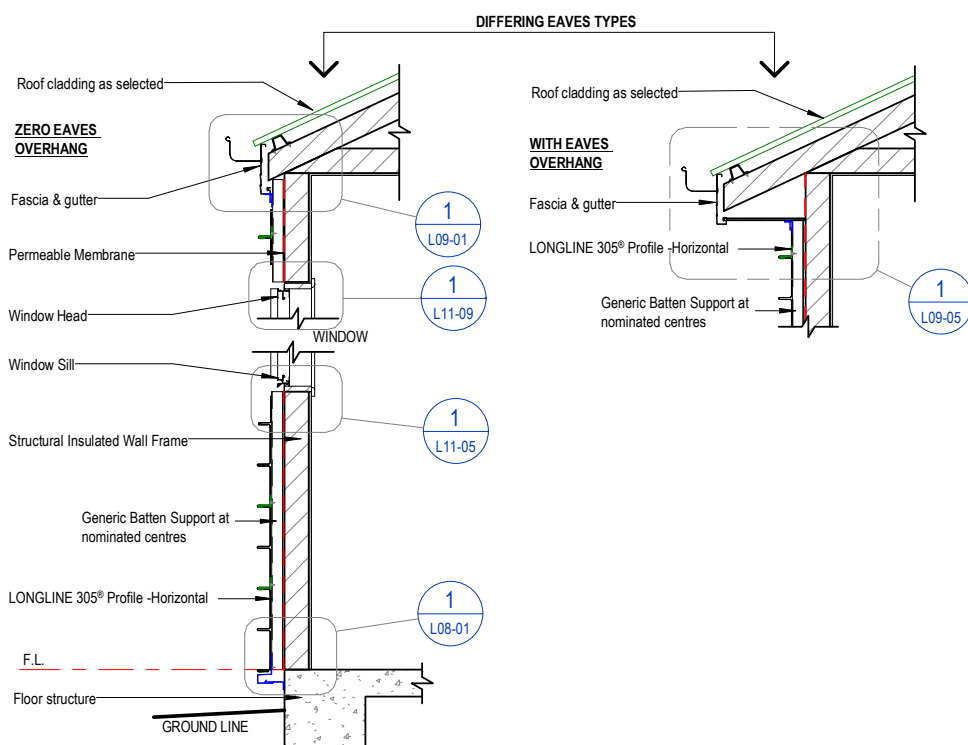

Figure 10.3.1.3:

External Corner - Unsupported LONGLINE 305® Panel - Horizontal Fix - L05-01

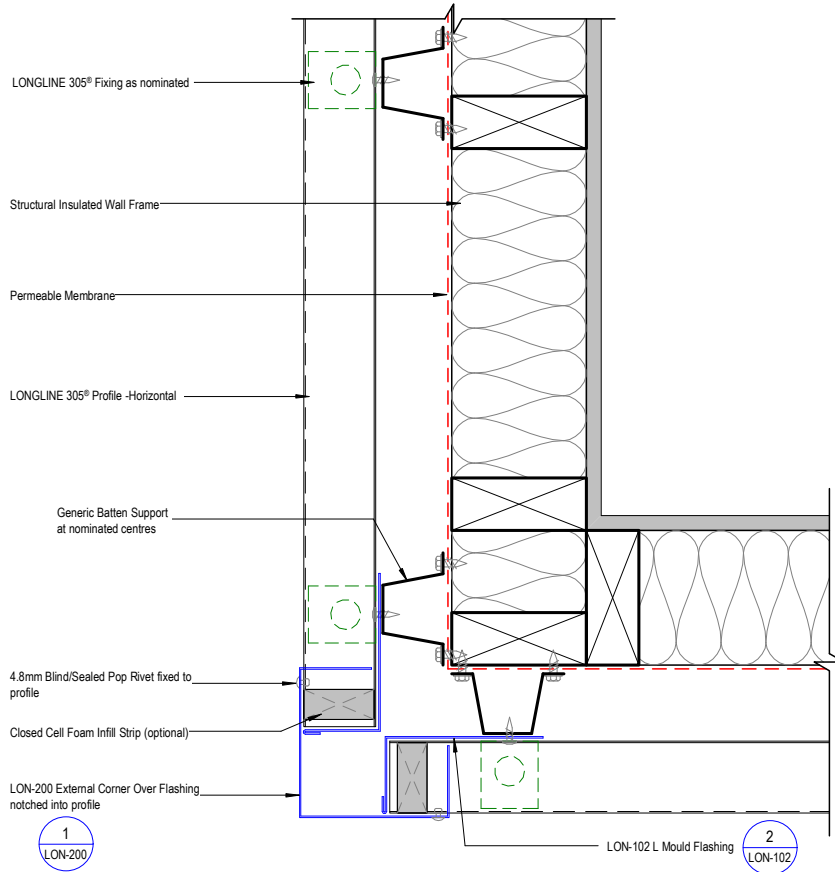

Figure 10.3.1.4:

Internal Corner - Unsupported LONGLINE 305® - Horizontal Fix - L06-01

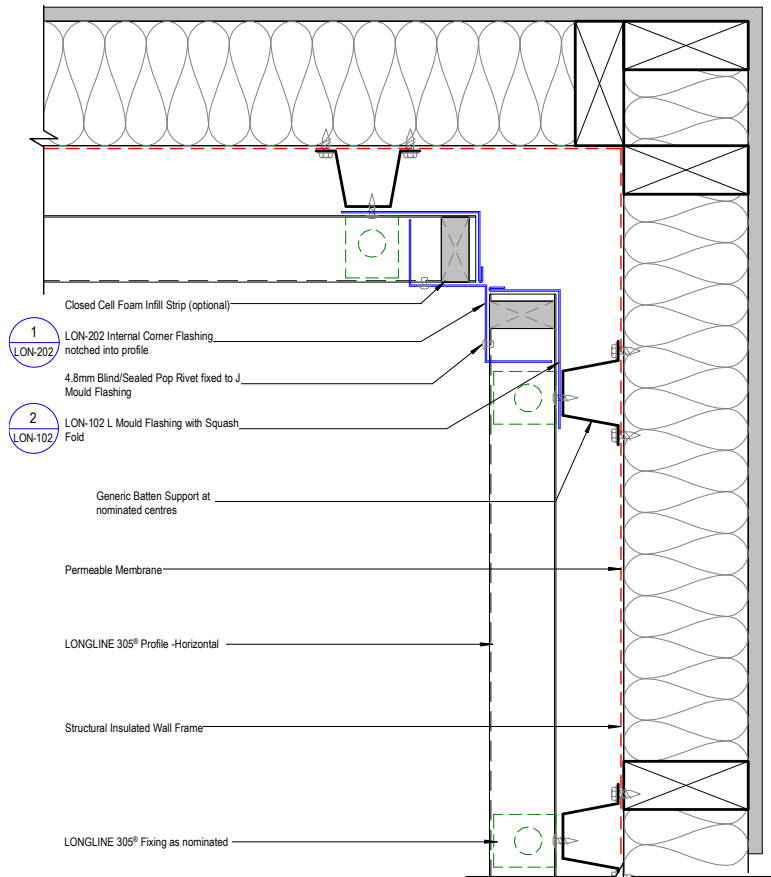

Figure 10.3.1.5:

Wall Closure Detail - Unsupported LONGLINE 305® Panel - Horizontal Fix - L07-01

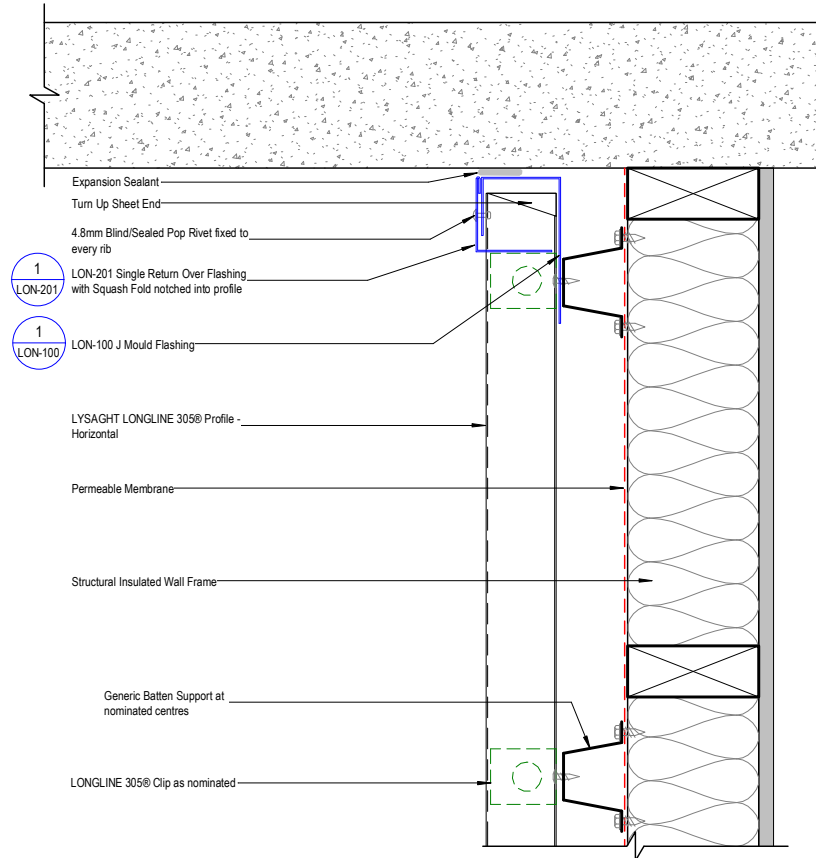

Figure 10.3.1.6:

Window Jamb Detail - Unsupported LONGLINE 305® - Horizontal Fix - L11-01

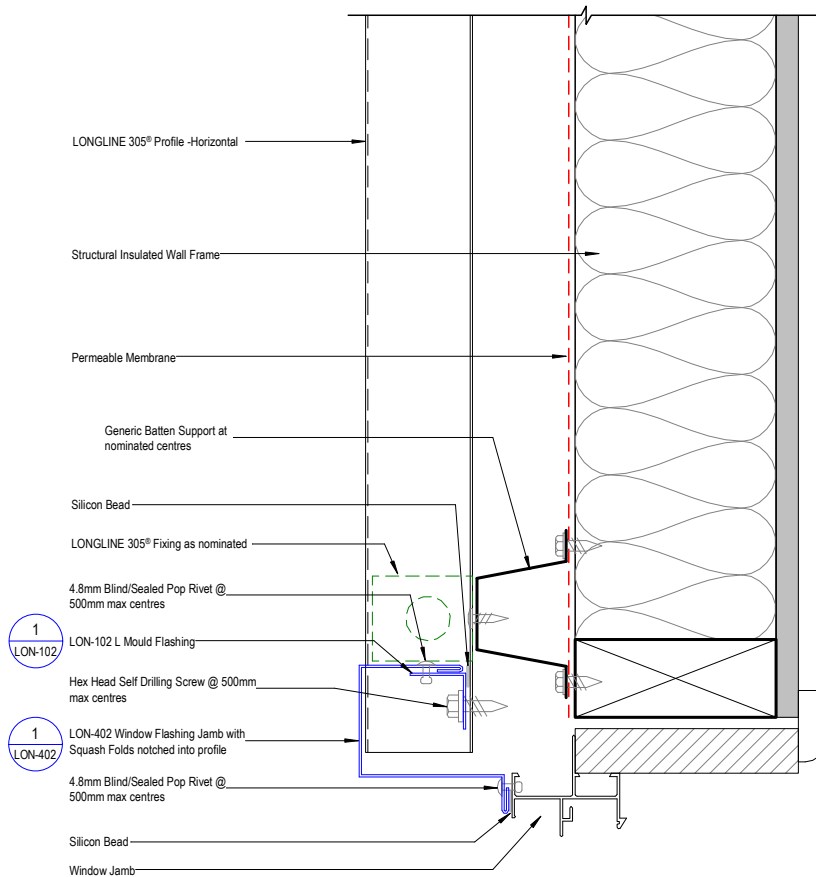

Figure 10.3.1.7:

Wall Base Detail - Unsupported LONGLINE 305® Panel - Horizontal Fix - L08-01

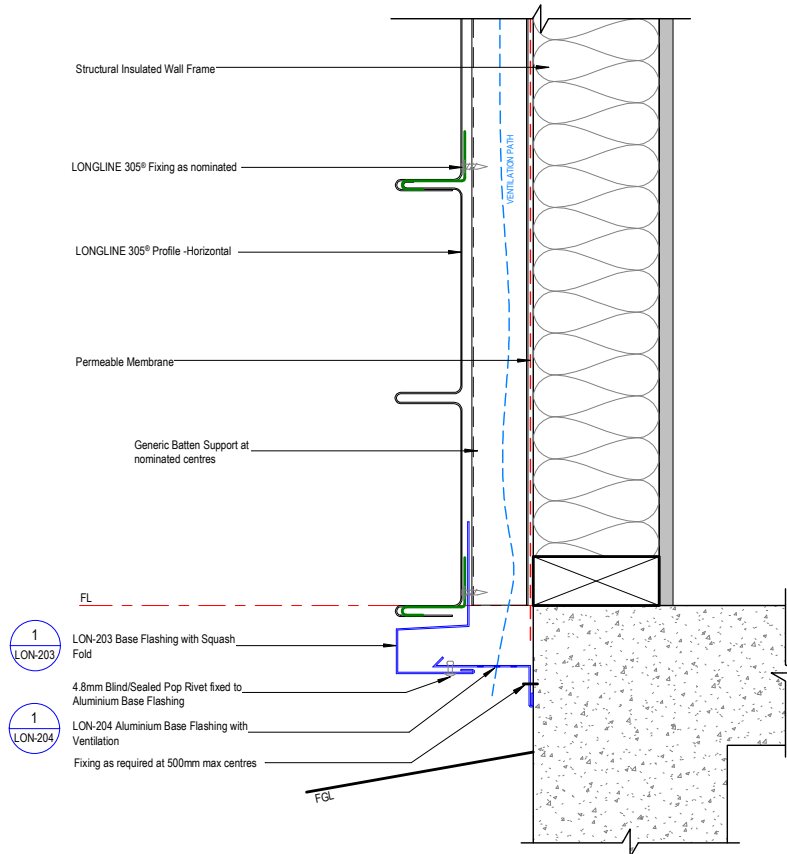

Figure 10.3.1.8:

Top of Wall Eave Detail - Zero Overhang - Unsupported LONGLINE 305® - Horizontal Fix - L09-01

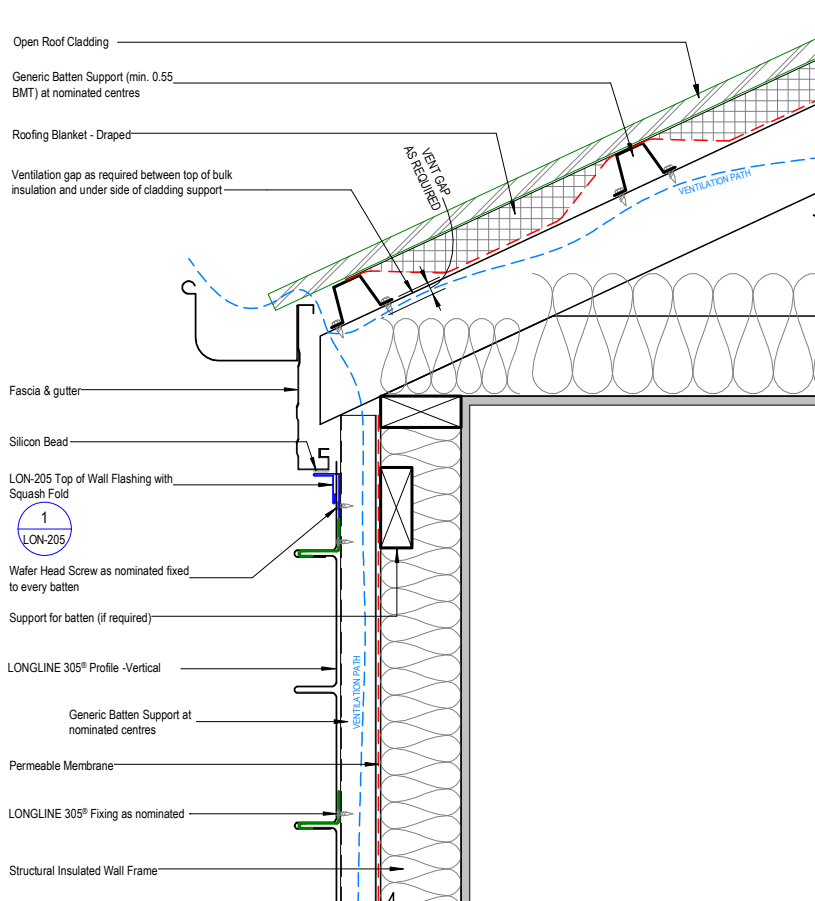

Figure 10.3.1.9:

Top of Wall Eave Detail - Overhang - Unsupported LONGLINE 305® - Horizontal Fix - L09-05

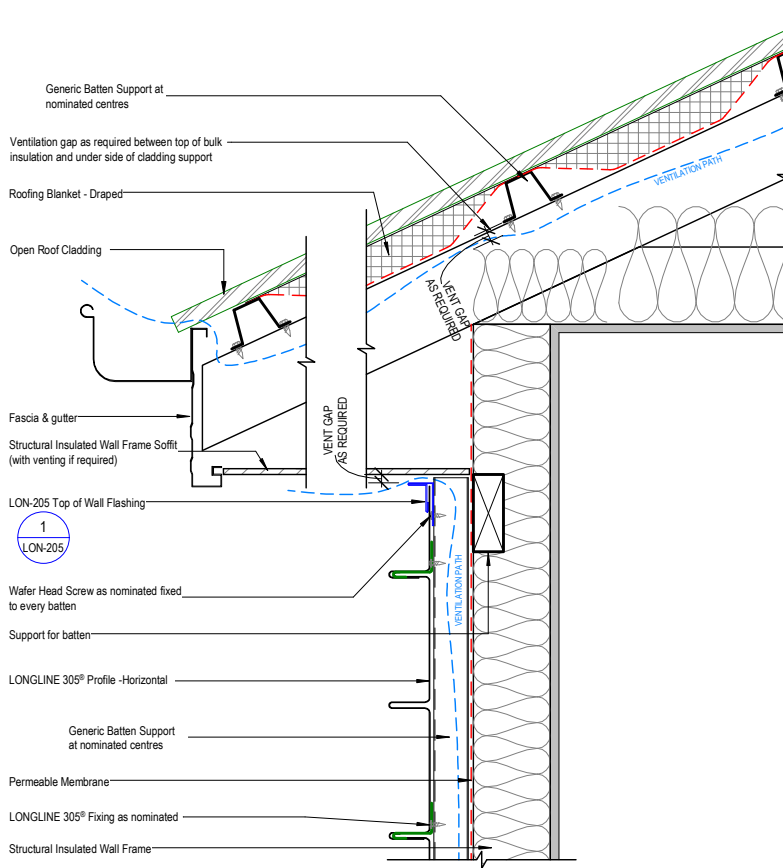

Figure 10.3.1.10:

Window Sill Detail - Unsupported LONGLINE 305® Panel - Horizontal Fix - L11-05

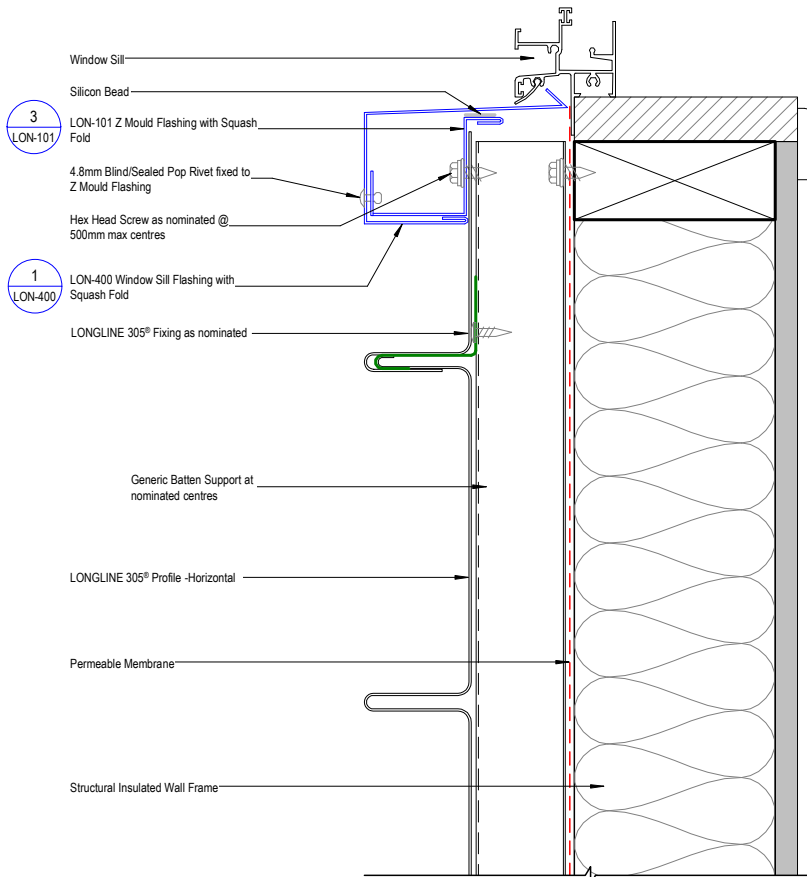
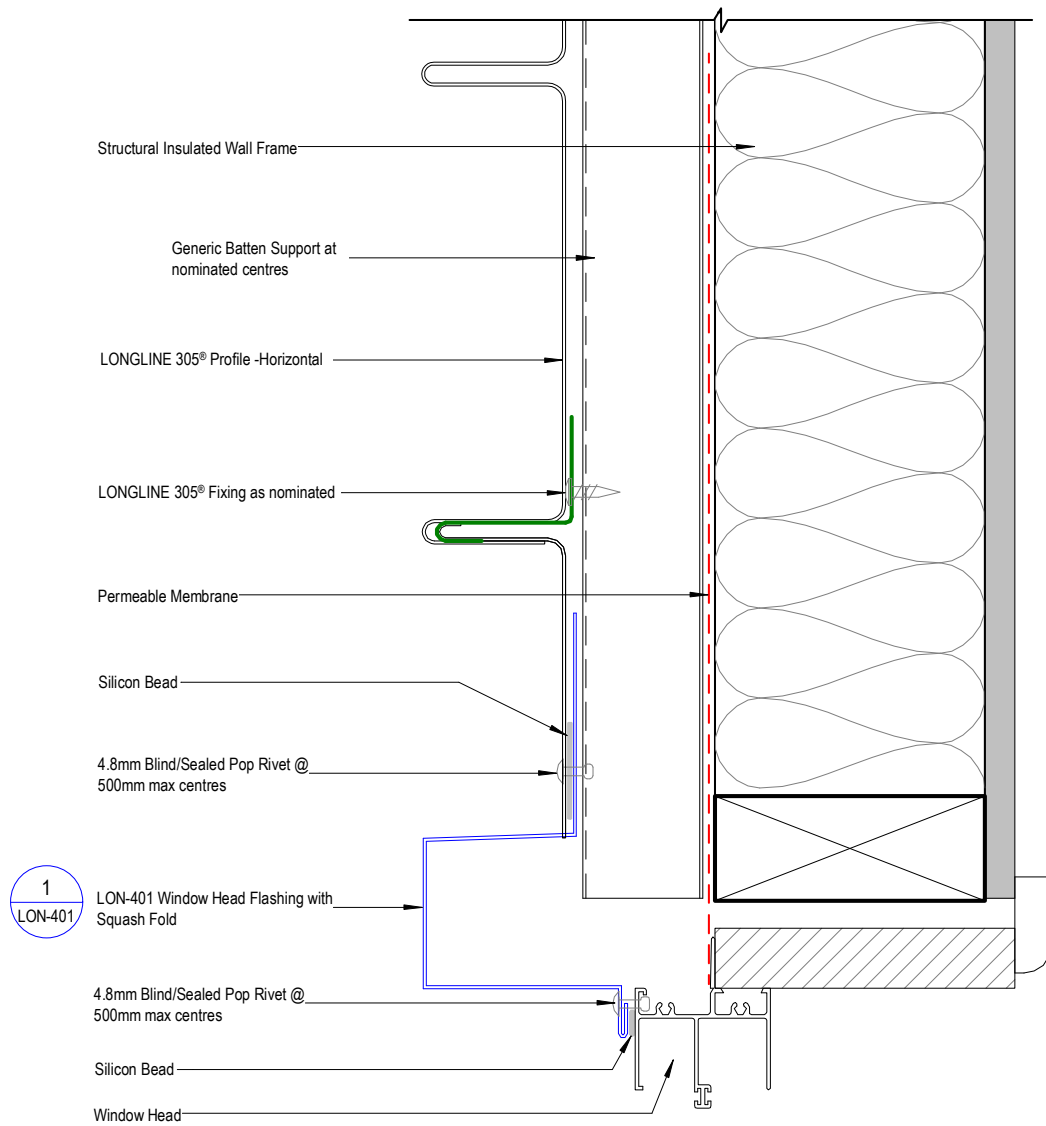

Figure 10.3.1.11:

Window Head Detail - Unsupported LONGLINE 305® Panel - Horizontal Fix - L11-09



10.3.2 LONGLINE 305® TYPICAL WALL DETAILS -VERTICAL FIX

Figure 10.3.2.1:

Typical Wall Cladding Setout - Unsupported LONGLINE 305® Vertical Fix - Plan View - L04-05

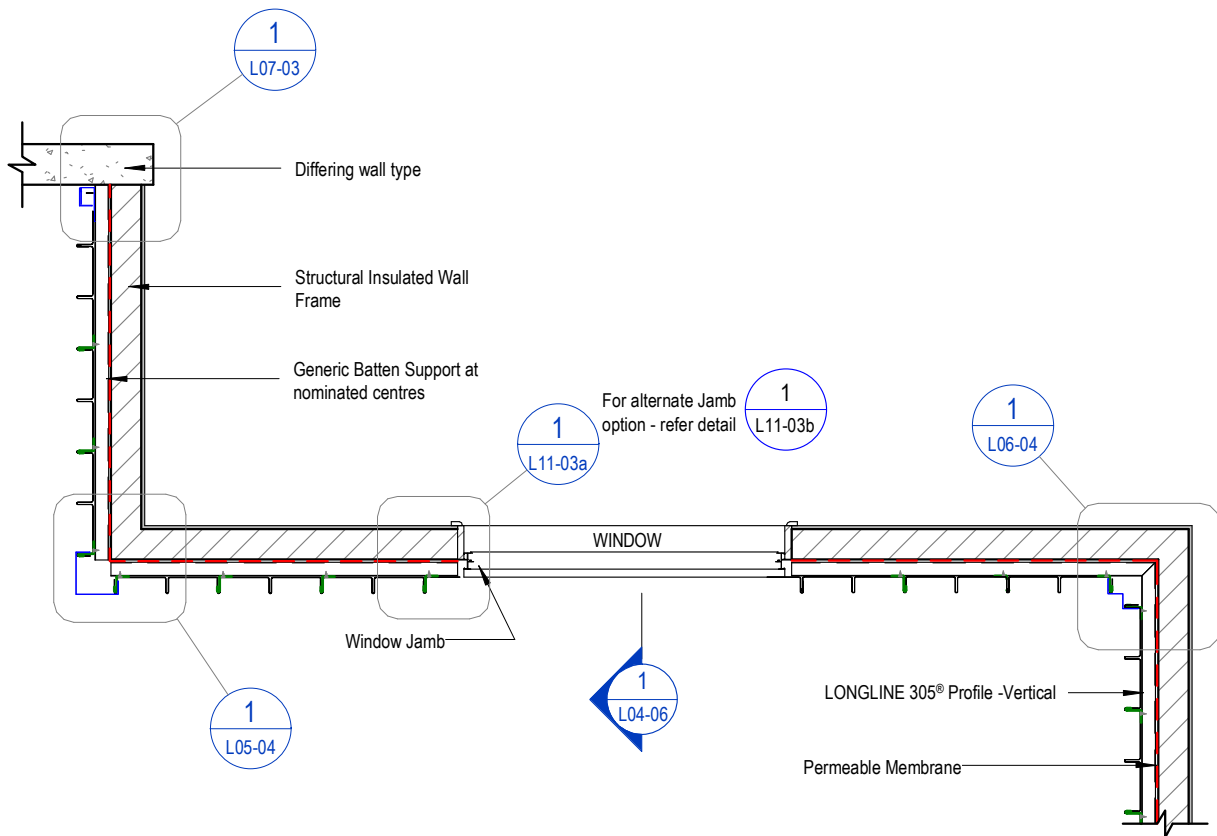

Figure 10.3.2.2:

Typical Wall Cladding Setout - Unsupported LONGLINE 305® - Vertical Fix - Sectional View - L04-06

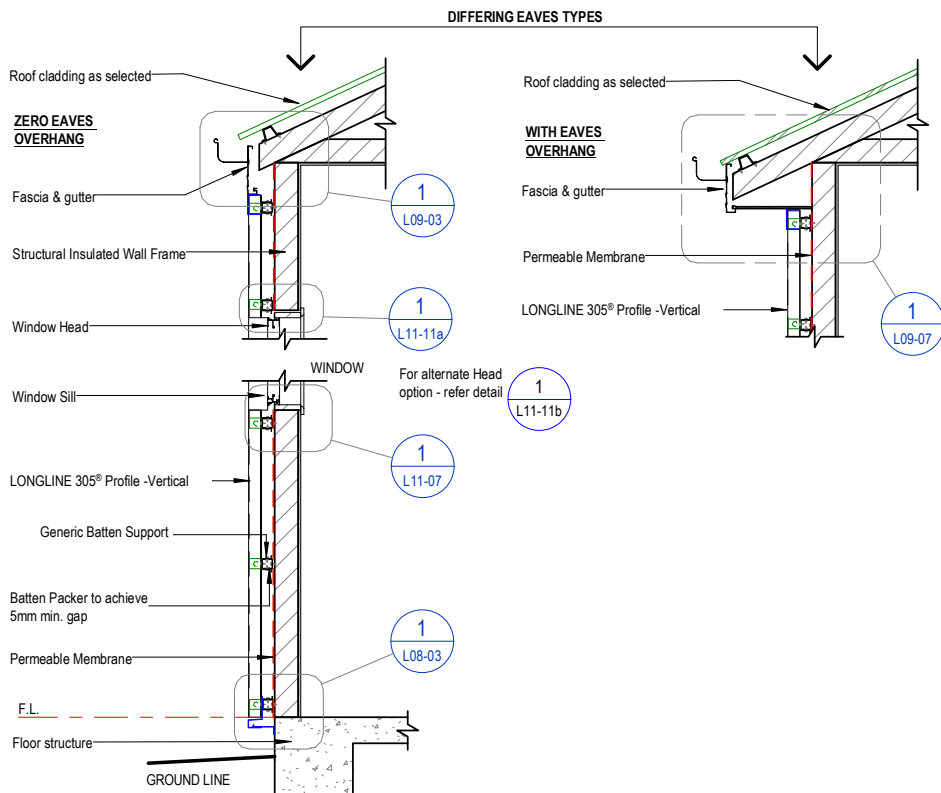

Figure 10.3.2.3:

External Corner Detail - Unsupported LONGLINE 305® Panel - L05-04

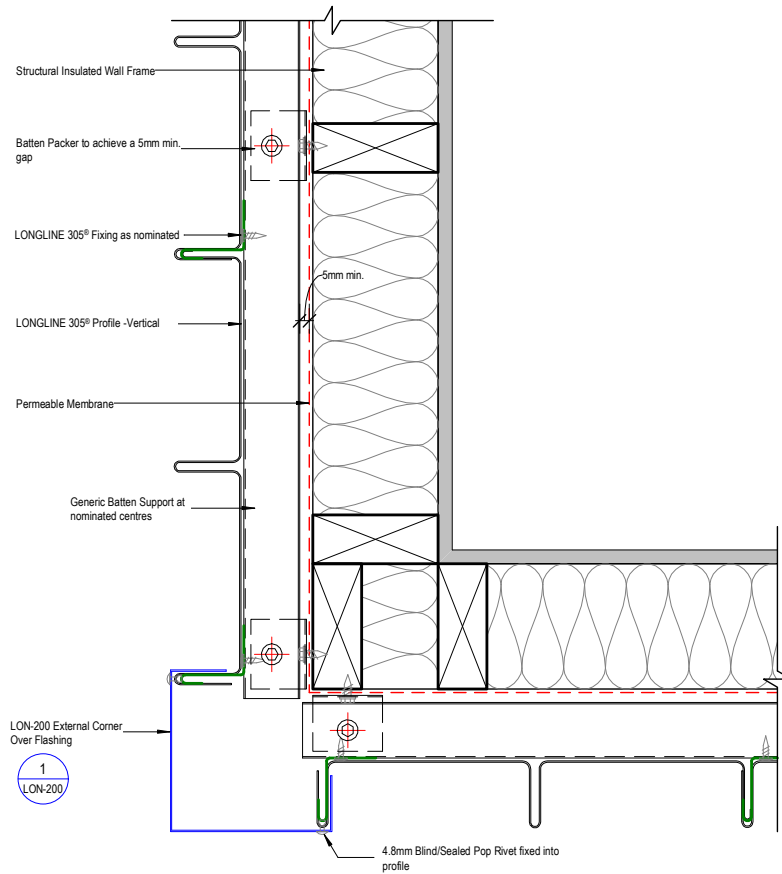

Figure 10.3.2.4:

Internal Corner Detail - Unsupported LONGLINE 305® - Vertical Fix - L06-04

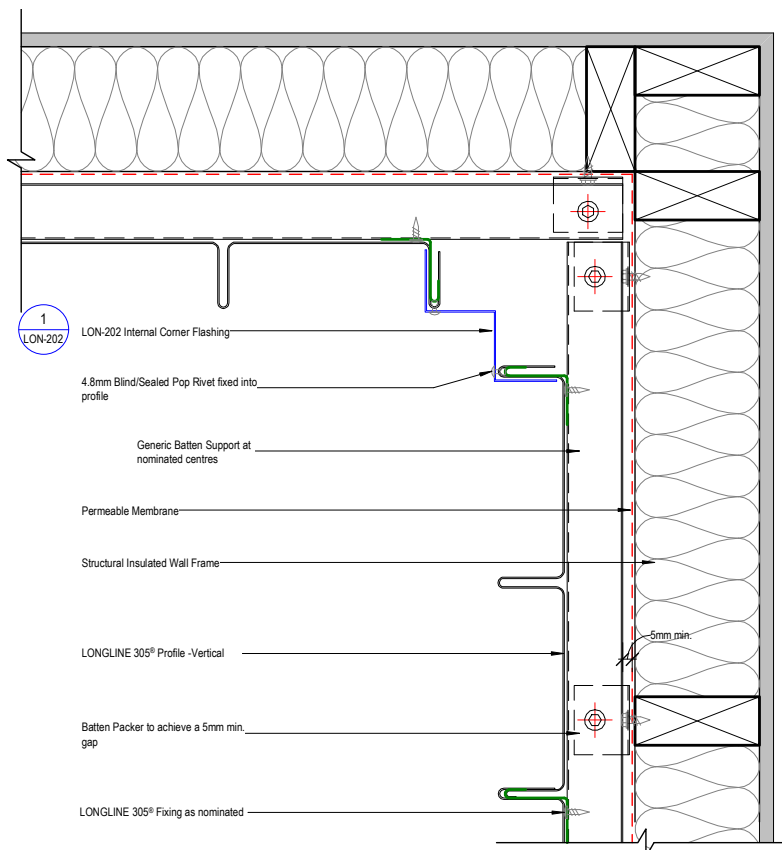

Figure 10.3.2.5:

Wall Closure Detail - Unsupported LONGLINE 305® Panel - Vertical Fix - L07-03

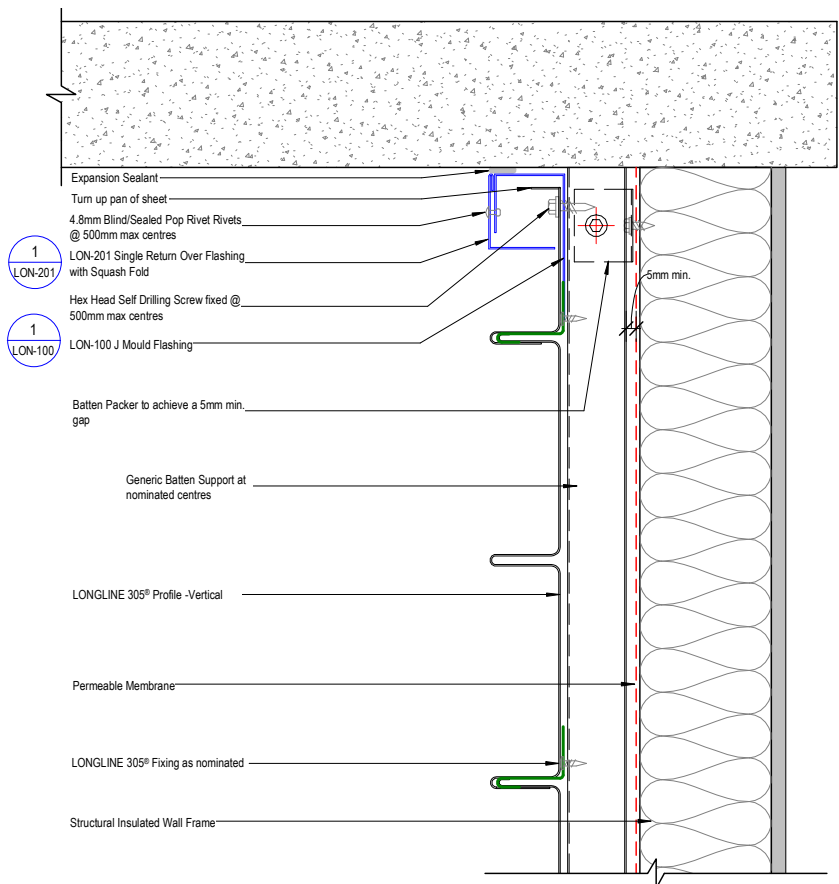

Figure 10.3.2.6:

Window Jamb Detail - Unsupported LONGLINE 305® Panel - Vertical Fix Option 1 - L11-03a

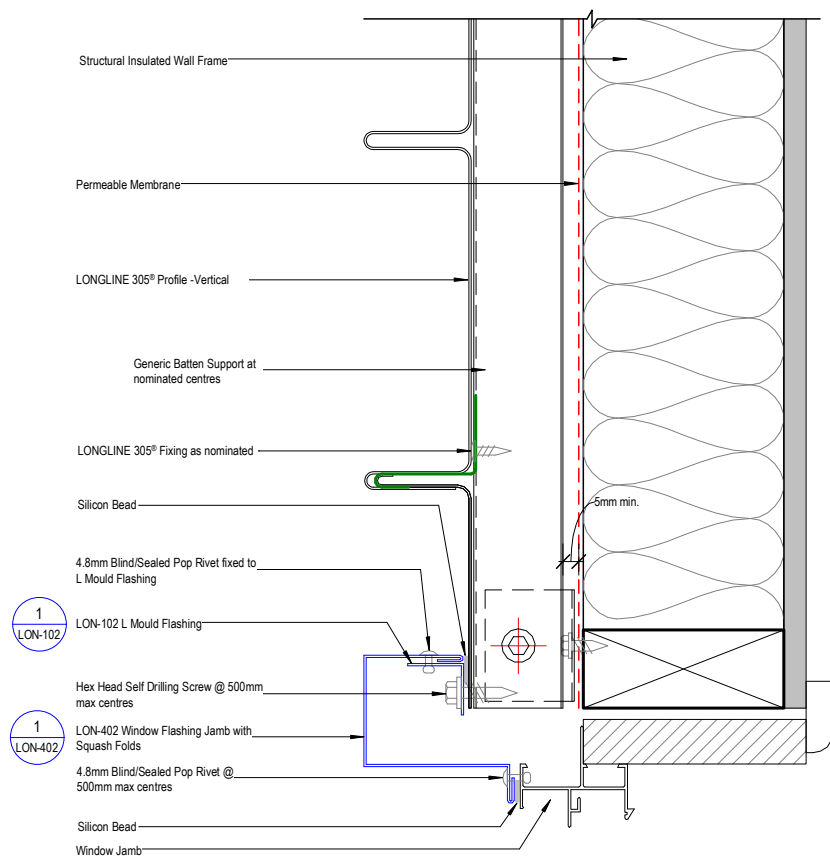

Figure 10.3.2.7:

Window Jamb Detail - Unsupported LONGLINE 305® Panel - Vertical Fix Option 2 - L11-03b

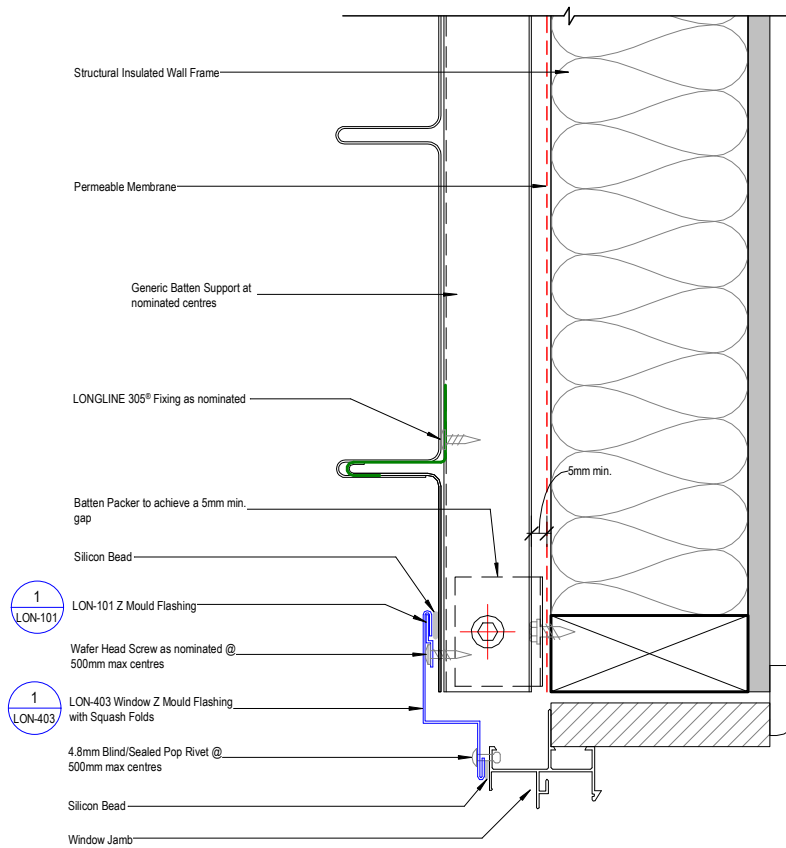

Figure 10.3.2.8:

Wall Base Detail - Unsupported LONGLINE 305® Panel - Vertical Fix - L08-03

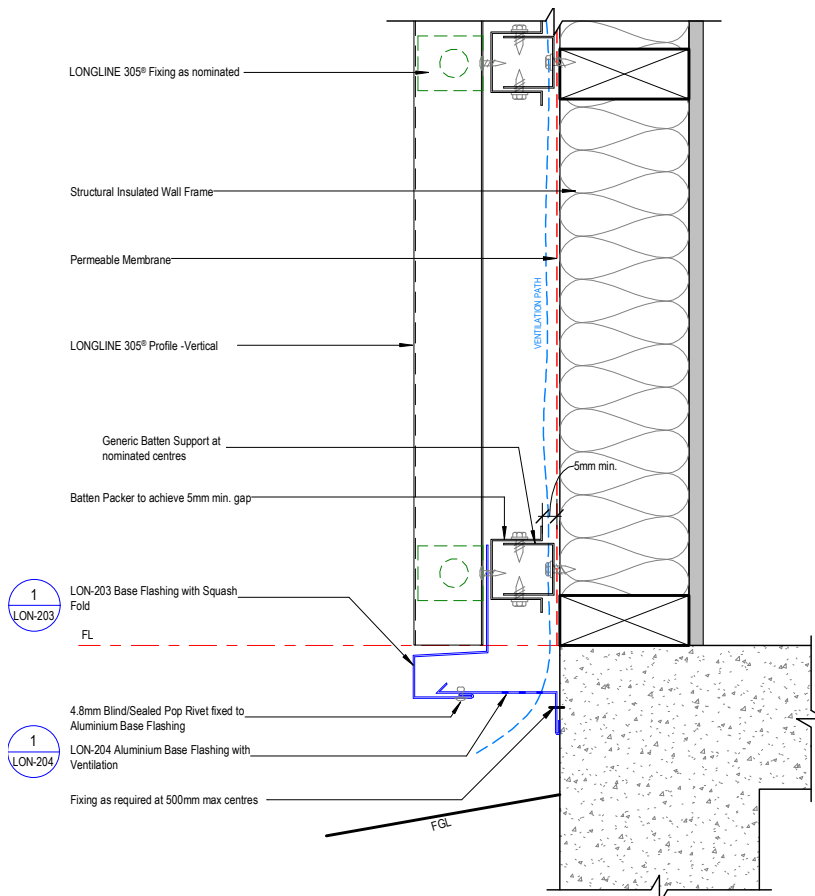

Figure 10.3.2.9:

Top of Wall Eave Detail - Zero Overhang - Unsupported LONGLINE 305® - Vertical Fix - L09-03

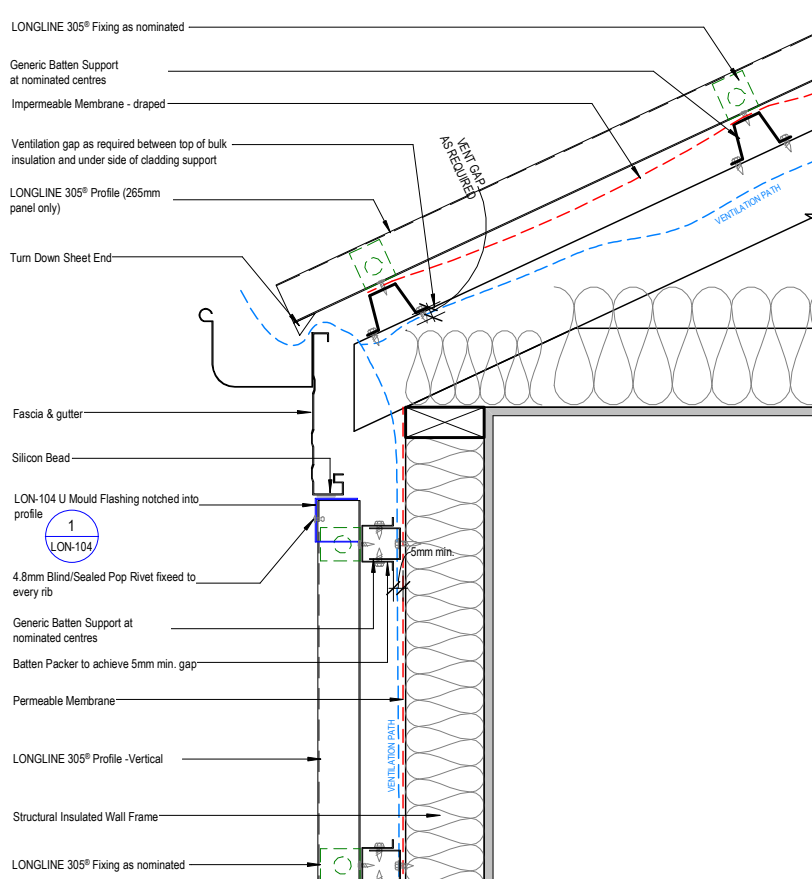

Figure 10.3.2.10:

Top of Wall Eave Detail - Overhang - Unsupported LONGLINE 305® - Vertical Fix - L09-07

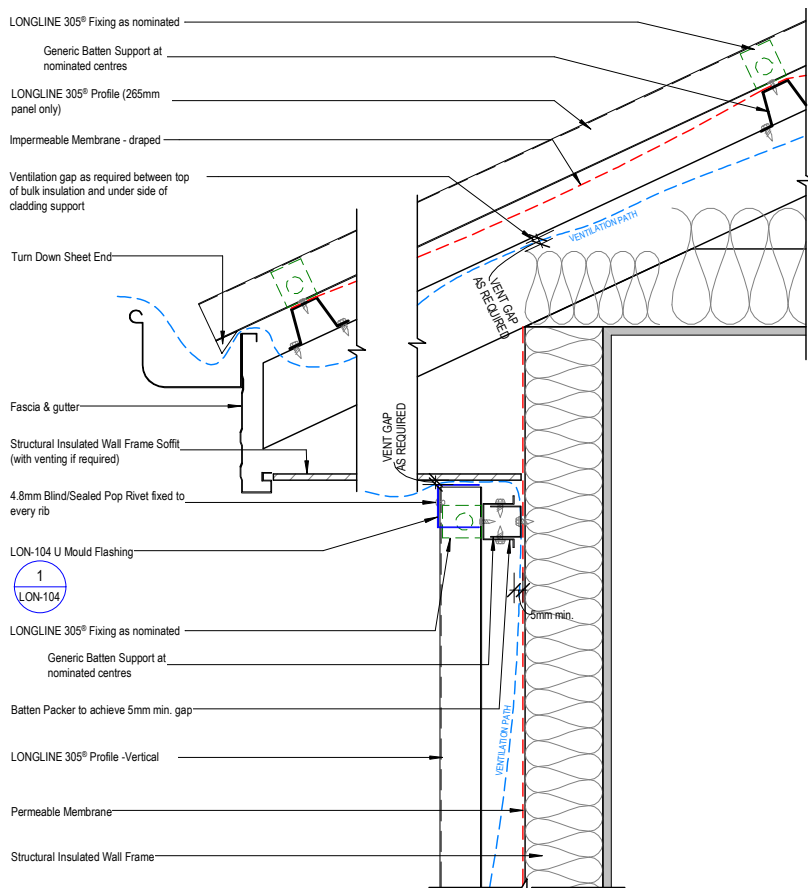

Figure 10.3.2.11:

Window Sill Detail - Unsupported LONGLINE 305® - Vertical Fix - L11-07

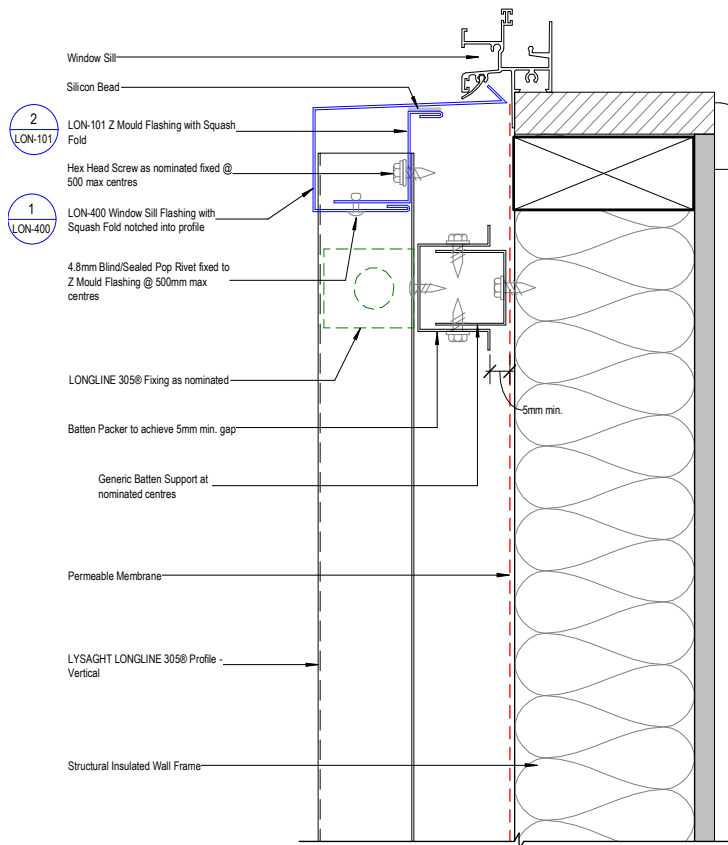

Figure 10.3.2.12:

Window Head Detail - Unsupported LONGLINE 305® Panel- Vertical Fix Option 1 - L11-11a

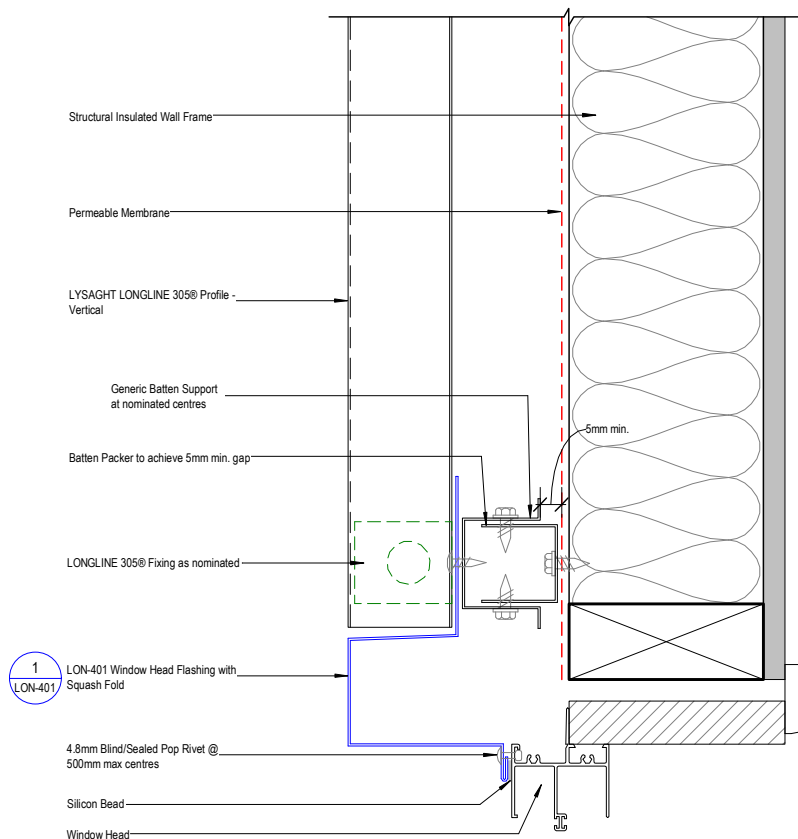
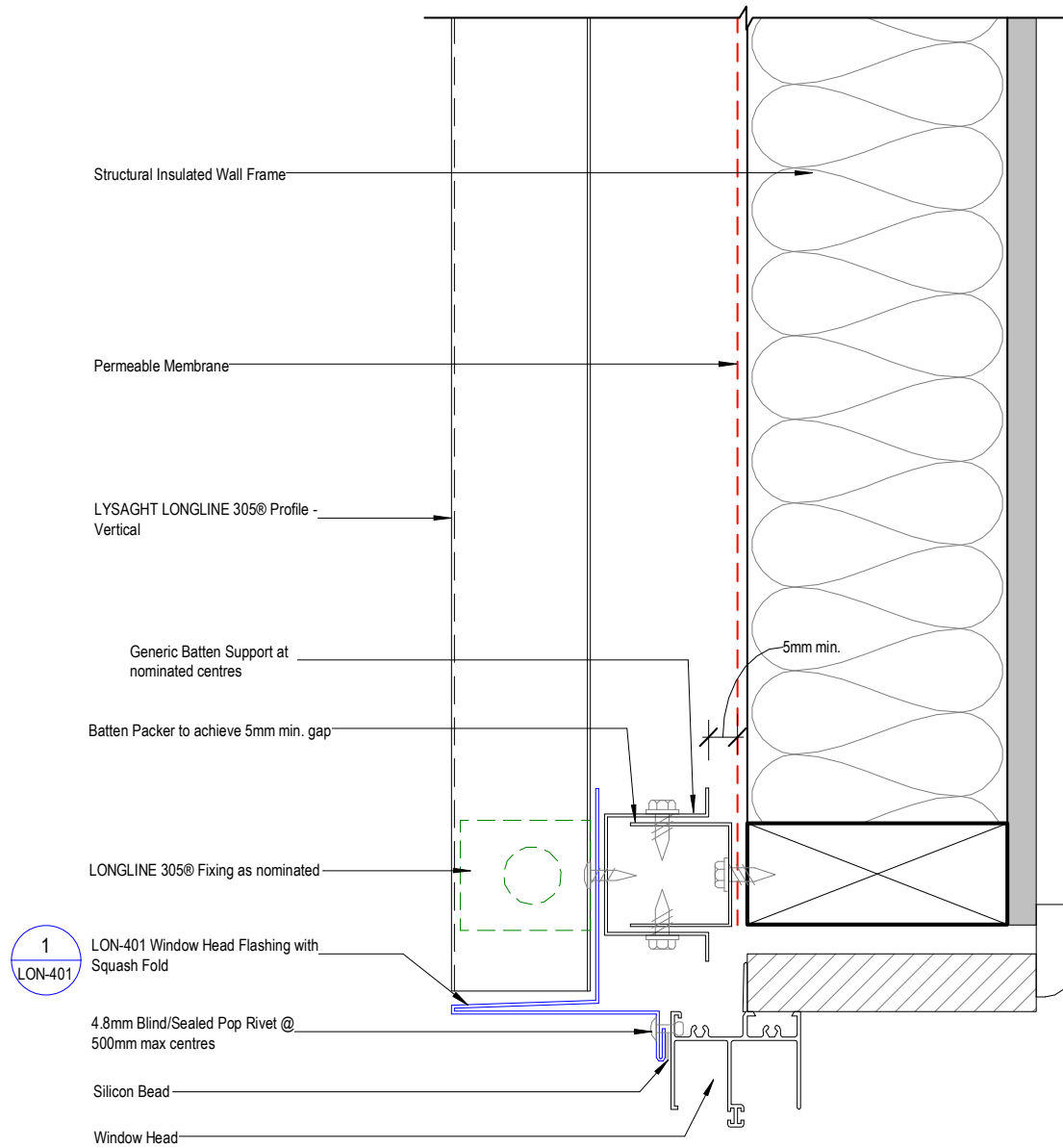

Figure 10.3.2.13:

Window Head Detail - Unsupported LONGLINE 305® Panel- Vertical Fix Option 2 - L11-11b



10.3.3 LONGLINE 305® TYPICAL FLASHINGS

Figure 10.3.3.1:

LON-100 - J Mould Flashings

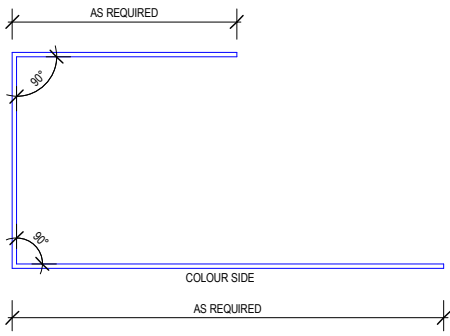

LON-100 - J Mould Flashing with Squash Fold

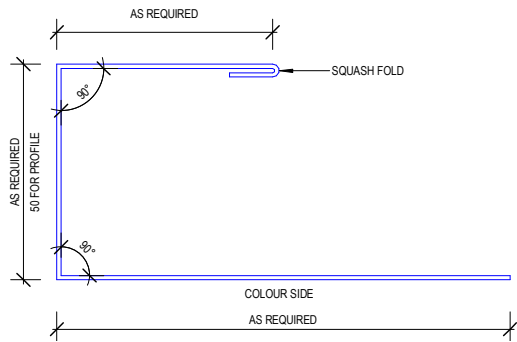
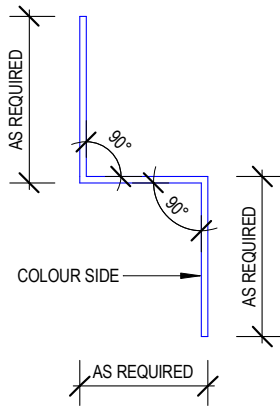

Figure 10.3.3.2:

LON-101 - Z Mould Flashings



LON-1010 - Z Mould Flashing with 1 Squash Fold

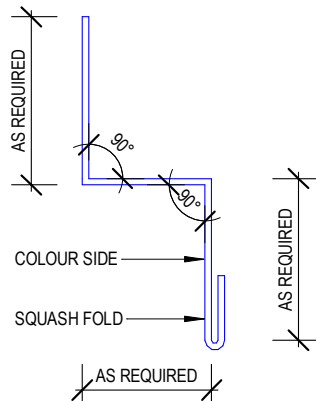
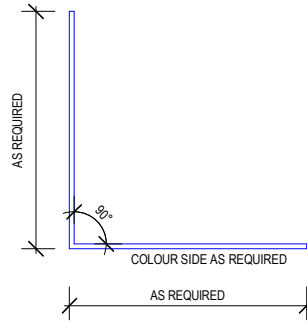
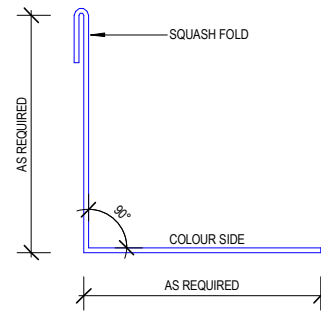

Figure 10.3.3.3:

LON-102 - L Mould Flashings



LON-102 - L Mould Flashing with 1 Squash Fold



LON-102 - L Mould Flashing with Squash Folds

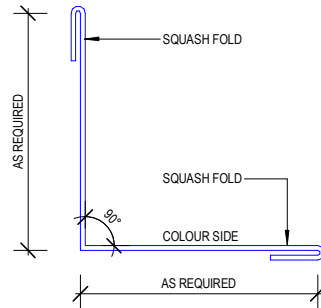
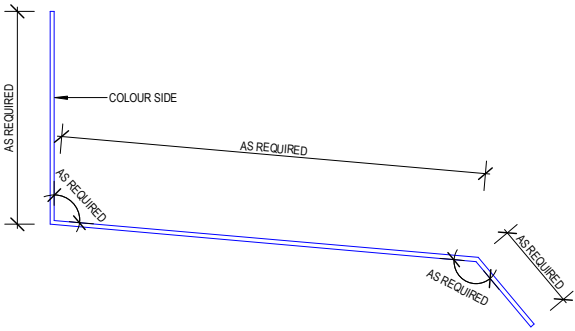

Figure 10.3.3.4:

LON-103 - Apron Flashings



LON-103 - Apron Flashing with Squash Fold

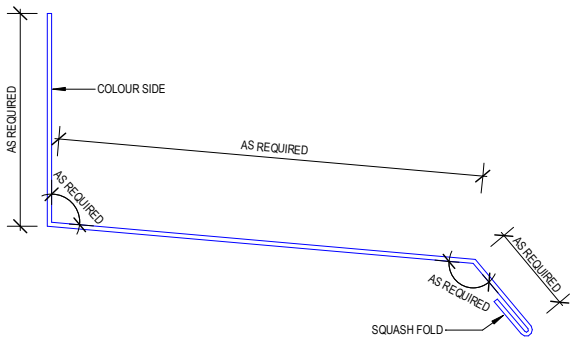

Figure 10.3.3.5:

LON-104 - U Mould Flashing

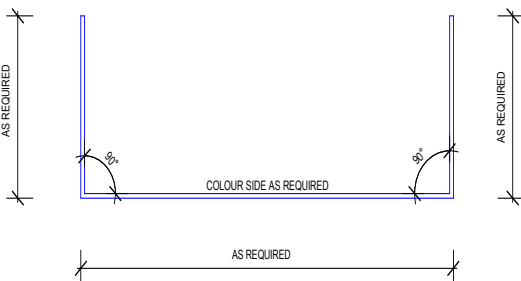

Figure 10.3.3.6:

LON-200 - External Corner Flashing

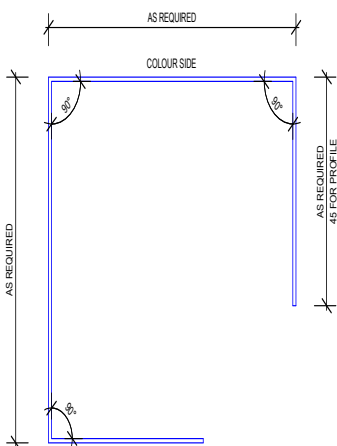

Figure 10.3.3.7:

LON-201 - Single Return Flashing

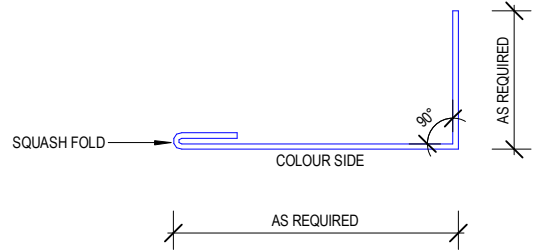

Figure 10.3.3.8:

LON-202 - Internal Corner Flashing

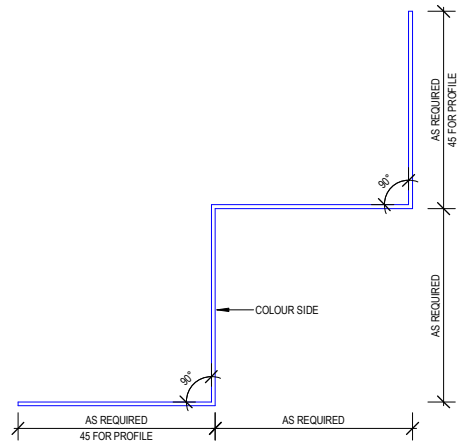
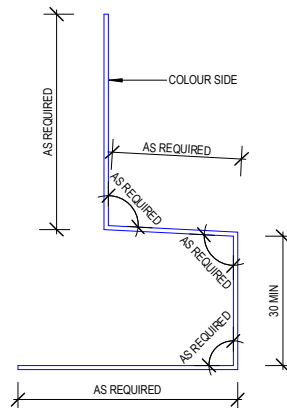

Figure 10.3.3.9:

LON-203 - Base Flashings



LON-203 - Base Flashing with Squash Fold

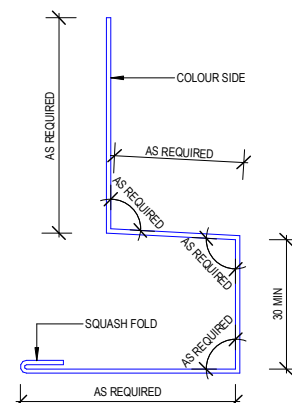

Figure 10.3.3.10:

LON-204 - Aluminium Base Flashing with Ventilation

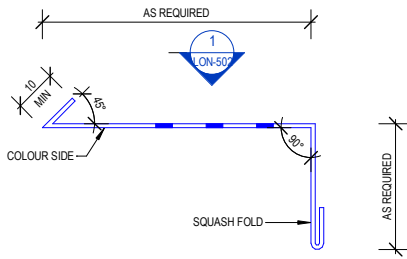

Figure 10.3.3.11:

LON-205 - Top of Wall Flashing

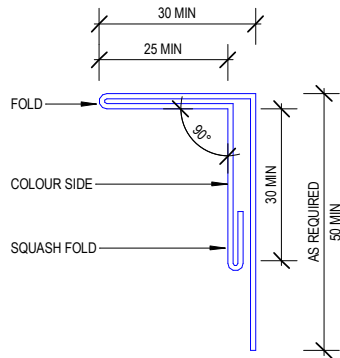
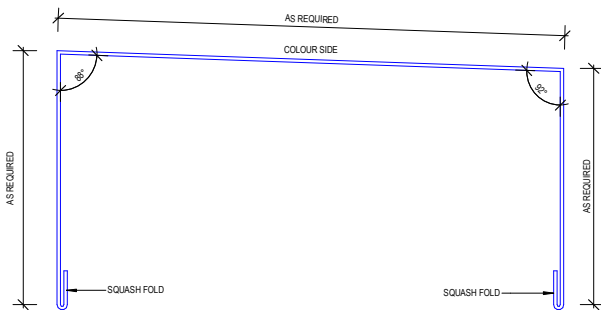

Figure 10.3.3.12:

LON-206 - Parapet Top Flashing with Squash Fold



LON-206 - Parapet Top Flashing with return and Squash Fold

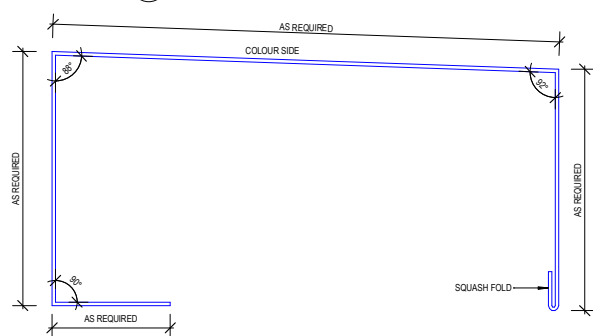

Figure 10.3.3.13:

LON-300 - Roof Valley Flashing

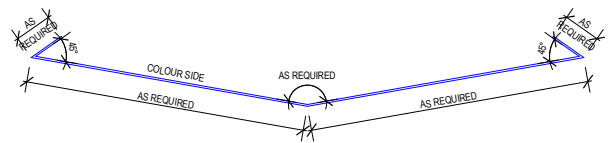
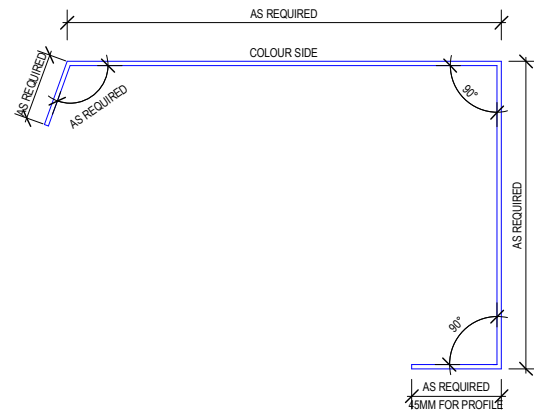

Figure 10.3.3.14:

LON-301 - Barge Flashing with returns



LON-301 - Barge Flashing with return and Squash Fold

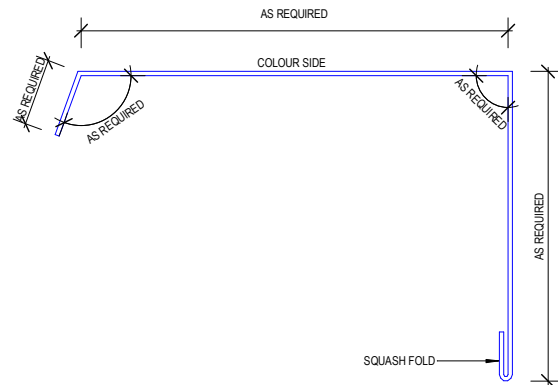

Figure 10.3.3.15:

LON-300 - Ridge Cap Flashing

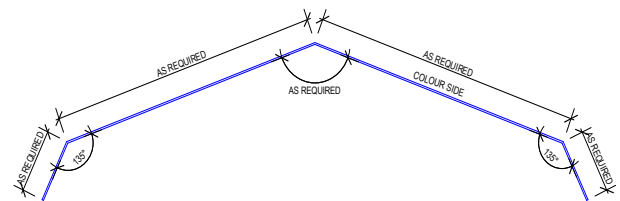

Figure 10.3.3.16:

LON-400 - Window Sill Flashing with Squash Fold

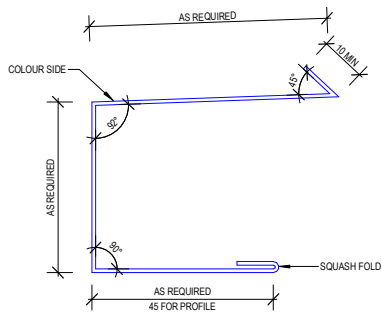

Figure 10.3.3.17:

LON-401 - Window Head Flashing with Squash Fold

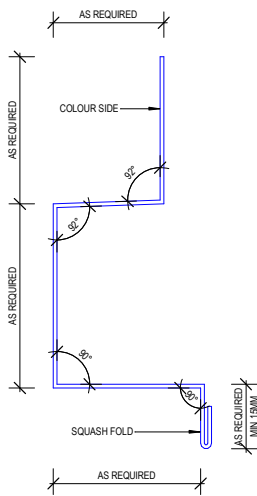

Figure 10.3.3.18:

LON-402 - Window Jamb Flashing with Squash Folds

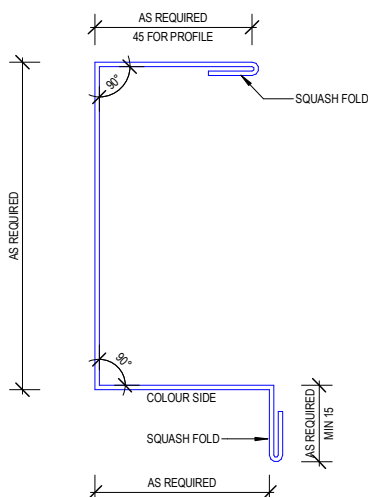
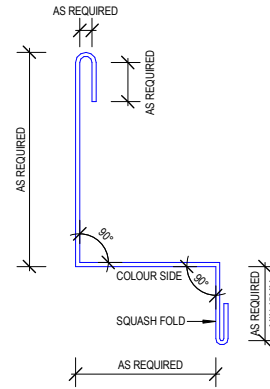

Figure 10.3.3.19:

LON-403 - Window Z Flashing with Squash Folds



LON-403 - Window Z Flashing with return and Squash Folds

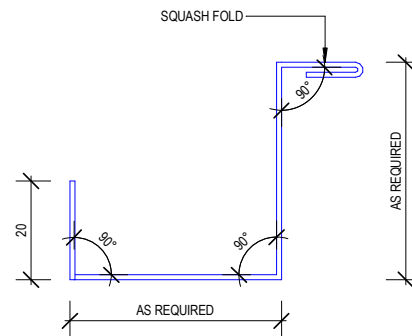

Figure 10.3.3.20:

LON-502 - Perforation Detail

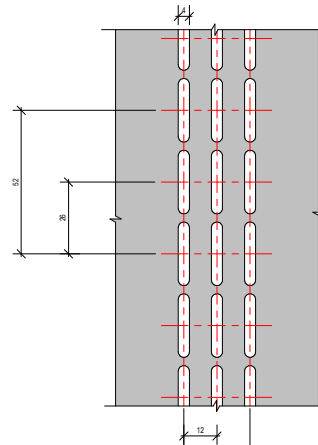
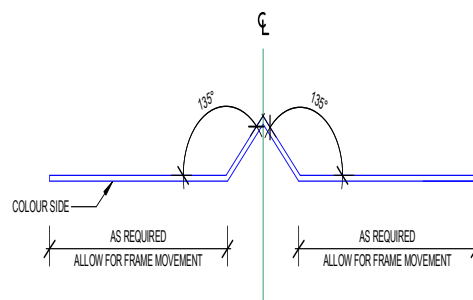

Figure 10.3.3.21:

LON-503 - Corrosion resistant flashing



11.0 ENSEAM® cyclonic roof and wall cladding

ENSEAM® architectural cladding is a concealed fixed flat panel cladding system. ENSEAM® is structurally sound for direct fixed to steel battens and can also be fixed onto conventional supporting substrate such as plywood or fibre cement panels.

The wide flat profile gives a modern architecturally designed premium finish.

11.1 MATERIAL SPECIFICATIONS

Coverage (mm)	265		
Base Metal Thickness (BMT) (mm)	0.55	0.7*	0.75*
Total Coated Thickness⁽¹⁾ (TCT) (mm)	0.6	0.75	0.8
Rib Height (mm)	38		
Sheet Length⁽²⁾ (mm)			
Minimum	500		
Maximum	8,000 ⁽²⁾		
Mass / Unit Length (kg/m)			
ZINCALUME® steel	1.83	2.25	2.41
COLORBOND® steel ⁽¹⁾	1.96	2.29	2.44
Mass / Unit Area (kg/m²)			
ZINCALUME® steel	6.91	8.50	9.09
COLORBOND® steel ⁽¹⁾	7.02	8.65	9.21
Minimum Yield Strength	300 (G300)		
Coating Class (See Base Material for detail)	AM125 - ZINCALUME® steel AM100 - COLORBOND® steel AM100 - COLORBOND® Metallic steel AM150 - COLORBOND® Ultra steel		
Tolerance	Sheet length: ±3mm Cover width: ±2mm		
Thermal Expansion	2.9mm average per 5m @ 50°C change		

Notes:

- Based on single sided COLORBOND® steel. For other painted steel options please contact your Lysaght representative.
- To assist minimising the effects of oil canning in ENSEAM® cladding, it is recommended to keep panel length under 8m. Longer lengths may be available subject to minimum order quantity.

*Please check with your local branch for availability.

MINIMUM ROOF PITCH

The minimum recommended roof pitch for ENSEAM® cyclonic cladding is 3 degree.

INSULATION

Care needs to be taken when installing insulation with ENSEAM® cyclonic roof sheeting. The screw length may need to be increased depending on the thickness and density of the insulation. When the screw is properly tightened into metal there should be a minimum of three (3) threads protruding past the support being fixed in to. For timber the screw must have a min embedment of 25mm into the timber.

For insulation, the use of roof spacing system is recommended to help maintain Rw values as well as minimising any bulging in the profile caused by the insulation. Refer to oil canning section for potential visual impacts of insulation on the product.

Figure 11.1.1:
ENSEAM® profile.

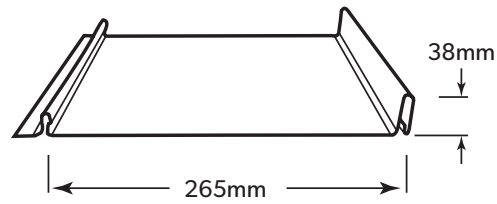

FASTENING ENSEAM® CLADDING TO SUPPORTS

ENSEAM® is concealed pierce-fixed to batten supports. This means that fastener screws pass through the sheeting at the concealed underlap edge. You can place screws through the slotted holes or directly through the sheet.

Table 11.1.1:

Fastener Specification - Cyclonic

Application	Fixing to steel	Fixing to plywood	Fixing to timber batten
Cyclonic	10g-16x16 waffer head metal screw with minimum class 3 coating + M5-15x1.2 galvanised steel washer At rib edge: 4.8mm Multigrip rivets or equivalent to stitch ribs at ends of sheet.	10g-12x25 waffer head type 17 screw with minimum class 3 coating + M5-15x1.2 galvanised steel washer At rib edge: 4.8mm Multigrip rivets or equivalent to stitch ribs at ends of sheet.	10g-12x25 waffer head type 17 screw with minimum class 3 coating + M5-15x1.2 galvanised steel washer At rib edge: 4.8mm Multigrip rivets or equivalent to stitch ribs at ends of sheet.

ENSEAM®: LIMIT STATE WIND PRESSURE CAPACITIES (KPA)

Cover width	Support Requirement	Design pressure (kPa)	Application
		Strength	
265mm x 0.55mm BMT	Steel batten: 40mm x 0.75mm BMT G550 Batten Spacing : 450mm (max) Batten span: 1200mm (max)	4.05	Walling
	* 15mm F11 CD Structural Grade plywood for walling applications Maximum support spacing 600mm Fastener spacing: 450mm	4.05	Walling
	Kingflor 40 0.75mm BMT G550 substrate support Maximum fastener spacing : 250mm Maximum substrate sheet span: 1200mm	4.05	Walling
265mm x 0.70mm BMT	Steel batten: 40mm x 0.75mm BMT G550 Maximum spacing: 600mm Maximum batten span: 900mm	4.54	Roofing & Walling
265mm x 0.75mm BMT	Steel batten: 40mm x 0.75mm BMT G550 Maximum spacing: 600mm Maximum batten span: 900mm	5.04	Roofing & Walling

Notes:

- Minimum support /purlin thickness must be 1.5mm BMT G450
- *15mm F11 structural grade plywood for pressure requirements-walling
- *19mm F11 Structural grade plywood for Impact requirements-walling

Table 11.1.2

Guide to fastener layout and sheet coverage.

SHEET COVERAGE

265MM

Width of Roof (m)	3	4	5	6	7	8	9	10	11	12	13	14	15	16	17	18	19	20	30	40	50
Number of Sheets	12	16	19	23	27	31	34	38	42	46	50	53	57	61	65	68	72	76	114	151	189

WIDTH COVERED BY 'X' NUMBERS OF SHEETS (M)

265MM

Number of Sheets	3	4	5	6	7	8	9	10	11	12	13	14	15	16	17	18	19	20
Coverage (m)	0.80	1.06	1.33	1.59	1.86	2.12	2.39	2.65	2.92	3.18	3.45	3.71	4.00	4.24	4.51	4.77	5.00	5.30

Screw calculation:

- 1.7 screws per 1m of cladding for 265mm roof /wall cladding based on 600mm batten spacing
- 2.3 screws per 1m of cladding for 265mm roof /wall cladding based on 450mm batten spacing

Figure 11.2.4:

Foam Infill detail.

80mm x 40mm closed cell foam infill cut to size and shape on site as required under ridge, hip or corner flashing

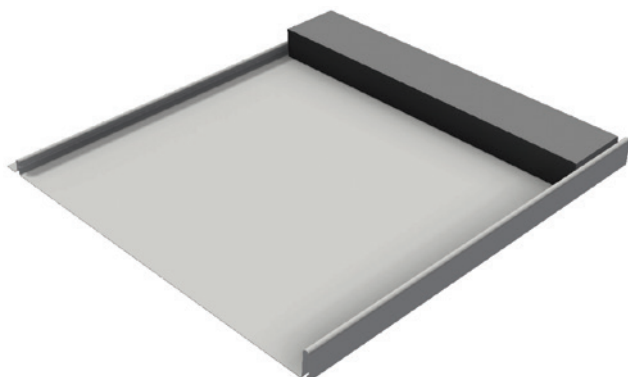

END LAPPING

Do not end lap ENSEAM® cladding.

ENDS OF SHEETS

It is usual to allow roof sheets to overhang into gutters by about 50mm.

LAYING PROCEDURE

ENSEAM® is designed to be installed in conjunction with a heavy duty roof sarking as an additional weather-proofing measure.

This sarking / blanket should be installed in accordance with the manufactures recommendations, sealed at the top, free from ripples and puckers, lapped and taped at joins. All laps in the sarking / blanket must be made with 150mm lap, sealed with double sided tape between the faces of the sarking and taped with sisal tape on the outside face.

For maximum weather-tightness, start laying sheets from the end of the building that will be in the lee of the worst-anticipated or prevailing weather. Lay sheets toward prevailing weather.

Also, it is much easier and safer to turn sheets on the ground than up on the roof. Before lifting sheets on to the roof, check that they are the correct way up and the overlapping side is towards the edge of the roof from which installation will start. Place bundles of sheets over or near firm supports, not at mid span of roof member.

1. Position the first sheet to align with the building edge.
2. Screw fix the under lap edge to battens or ply as shown in Figure 11.2.1 and Figure 11.2.2 taking care to place the screws to the centre of the slotted holes to allow for expansion and contraction.
3. Align and engage the next sheet as shown in Figure 11.2.4 and then screw fix as per Step 2.
4. Repeat for the roof/wall run.
5. Complete flashings and detailing as per details 11.2.5 to 11.2.15 and architectural directions.

11.2 TYPICAL INSTALLATION DETAILS

Figure 11.2.1:

Fixing to steel batten.

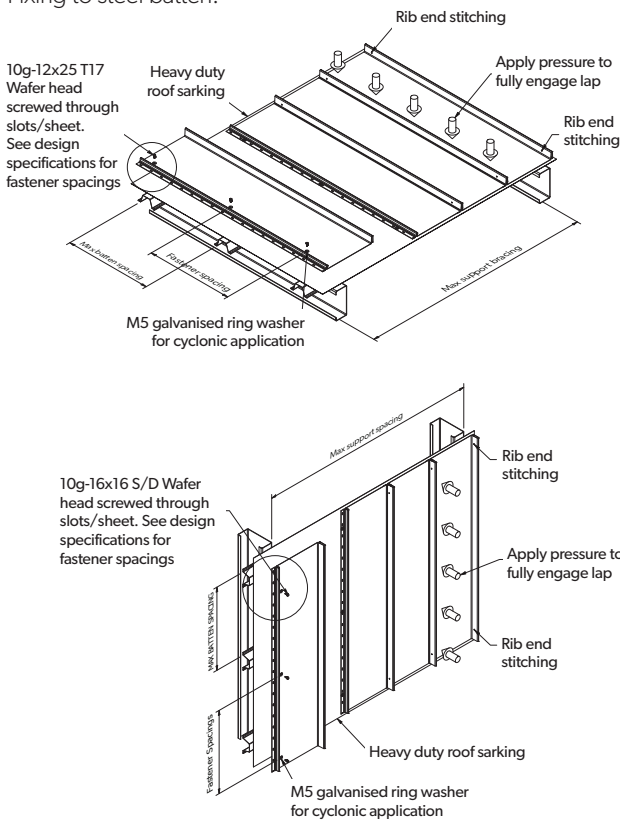

Figure 11.2.2:

Fixing to plywood detail.

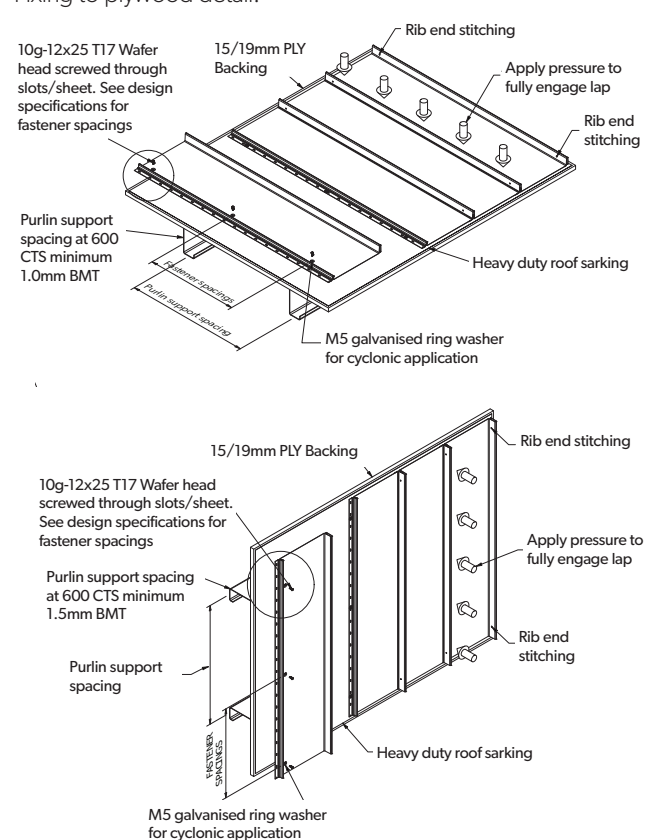
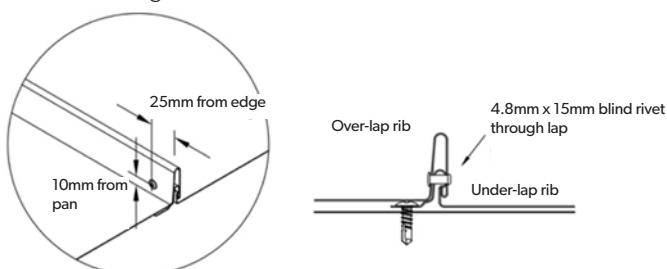

Figure 11.2.3:

Rib end stitching detail.



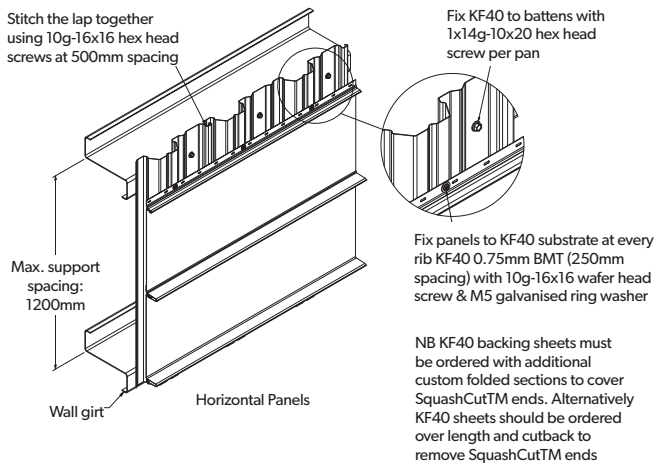
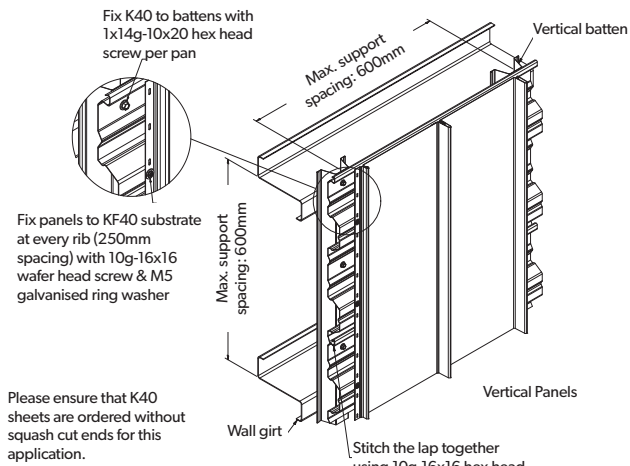
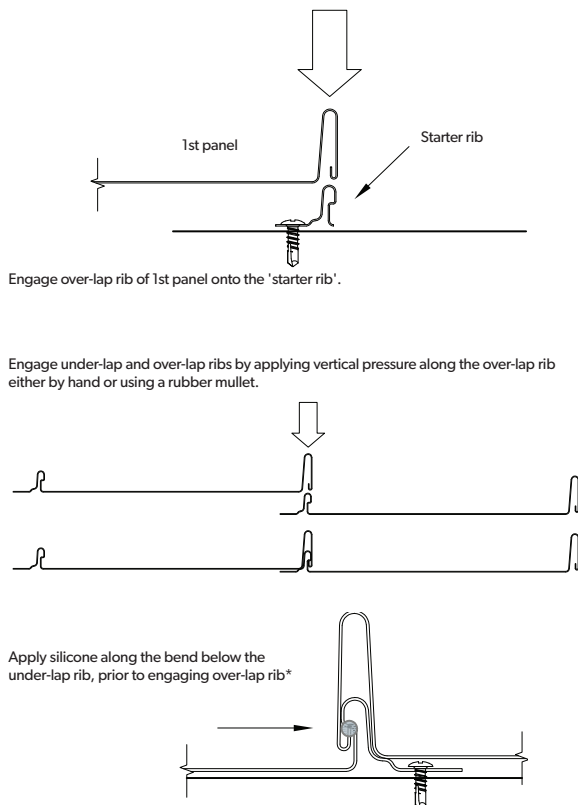

Figure 11.2.4:

Standard lap engagement procedure.



When roof pitch is under 7.5° or total combined sheet length is over 5m

TYPICAL STOP END DETAIL

Stop end procedure:

1. Place pan into the panel stop end tool, the front edge of the tool must rest between the rib.
2. While maintaining pressure against the panel, rotate the stop end tool as close to 90° as possible.
3. Inspect completed bend.

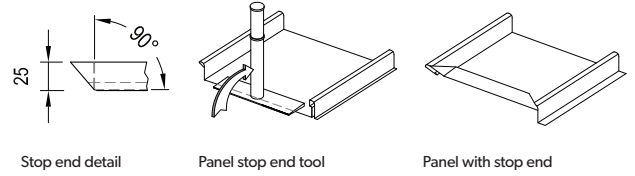

TYPICAL TURN DOWN DETAIL

1. Panels requiring field hemmed ends should be fabricated 25mm longer than the finished panel length. Valley heavy duty roof sarking conditions must be field cut to the appropriate angle.
2. Cut back panel joints 25mm.
3. Place protruding pan into the panel hemming tool, the front edge of the tool must rest against the notched joint legs on both sides.
4. While maintaining pressure against the panel joints, rotate the hemming tool as close to 90° as possible.

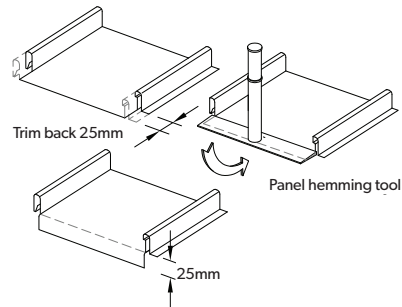

Figure 11.2.6:

Wall to roof detail.

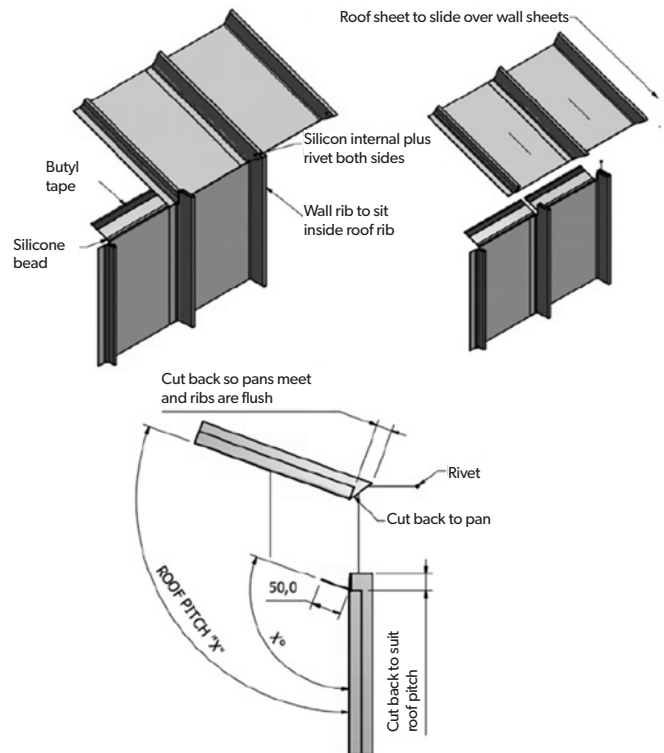

Figure 11.2.7:

Typical higher eave detail - metal batten.

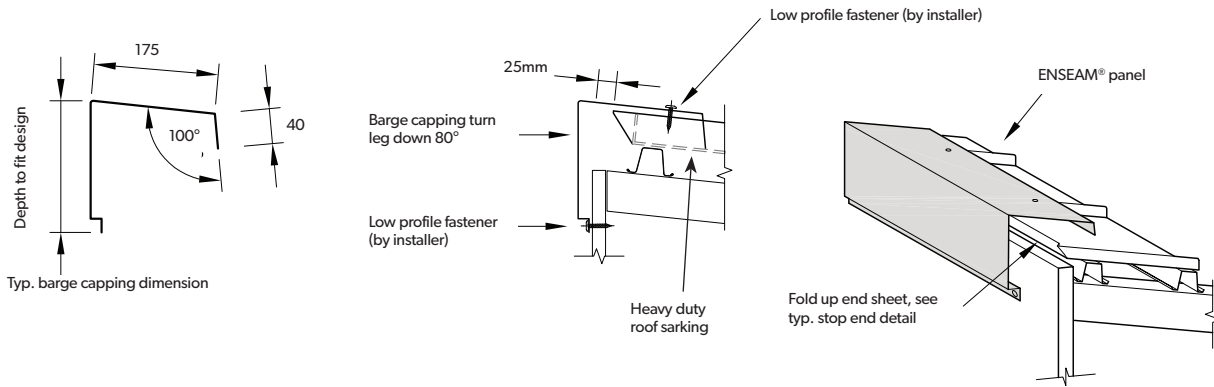

Figure 11.2.8:

Typical higher eave detail - plywood.

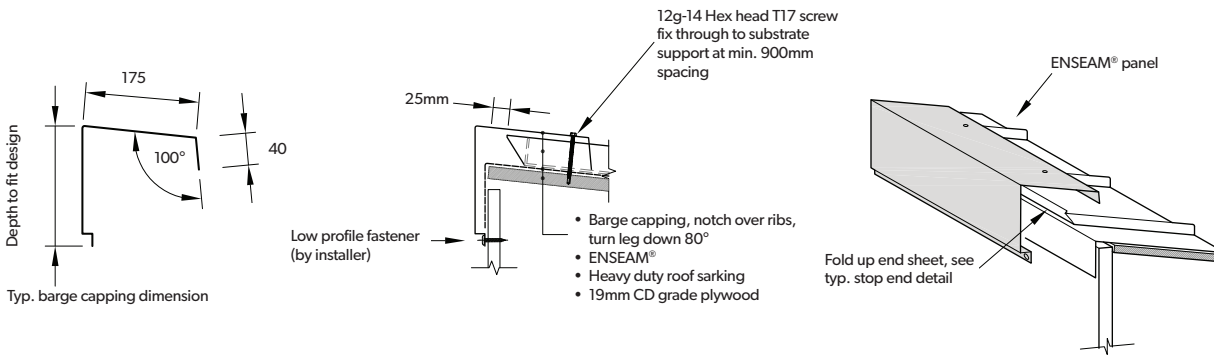

Figure 11.2.9:

Typical barge detail – metal batten.

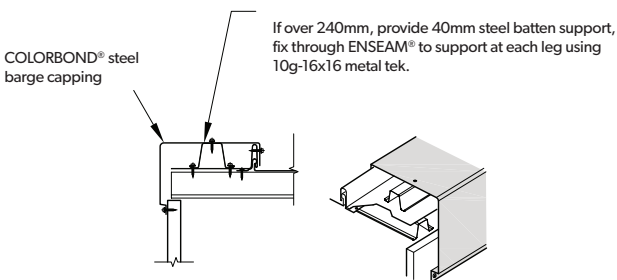

Figure 11.2.10:

Typical barge detail – plywood.

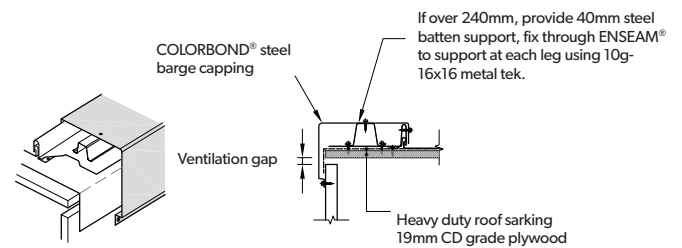

Figure 11.2.11:

Ridge detail – metal batten.

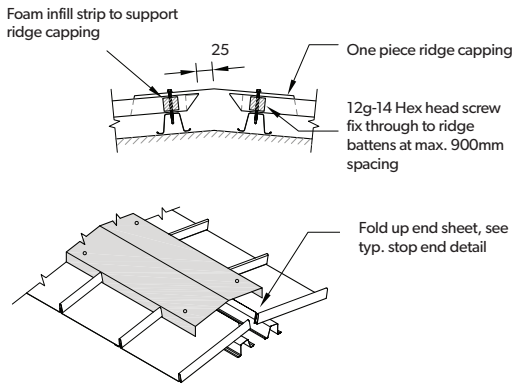

Figure 11.2.12:

Ridge detail – metal batten.

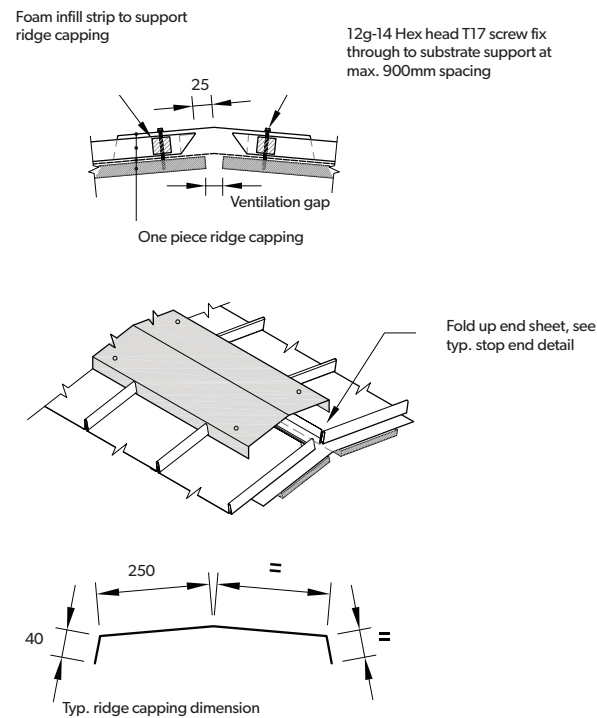

Figure 11.2.13:

Valley gutter detail - battens.

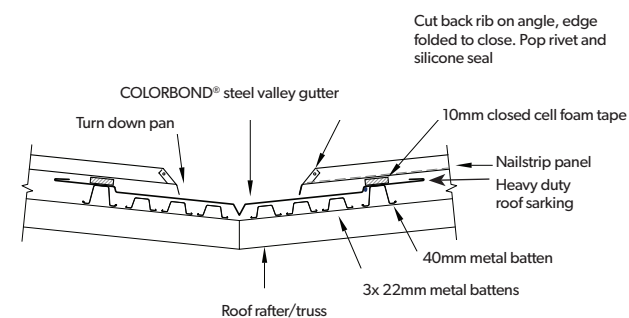

Figure 11.2.14:

Valley gutter detail - plywood.

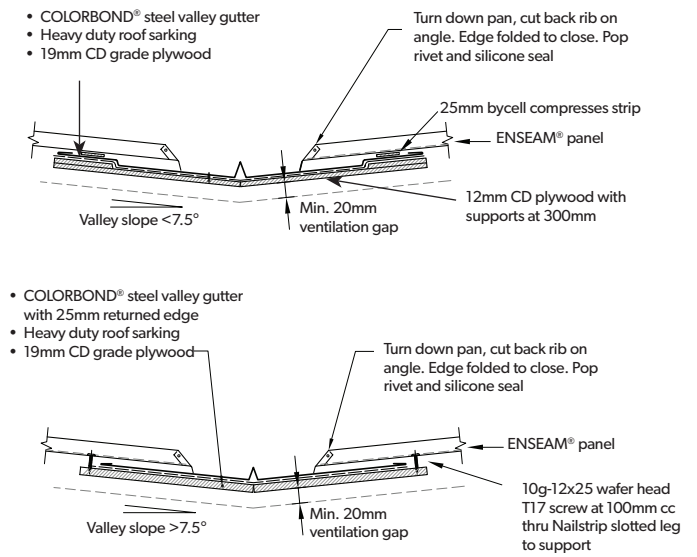
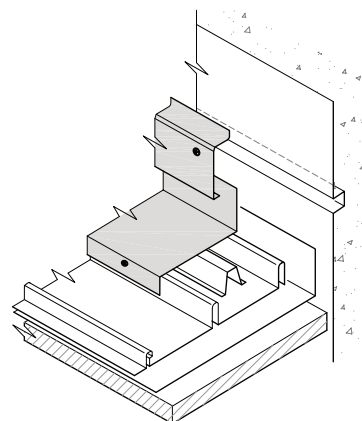
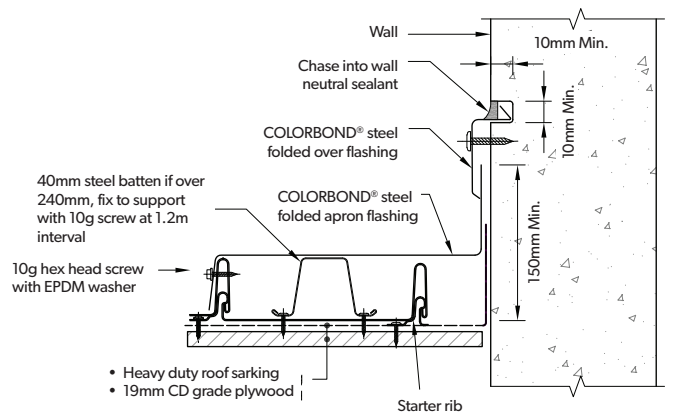

Figure 11.2.15:

Apron flashing detail.



11.3 TYPICAL CONSTRUCTION DETAILS ENSEAM®

The construction details presented here represent potential detailing solutions to common construction situations. These details may not be suitable for all projects / situations and users should use professional judgement in determining suitability of the details for their particular project whilst referencing AS 1562.1 and SA HB39. The full suite of ZENITH® constructions details are available for download from <https://bimcontent.com/lysaght/> in both REVIT and PDF format.

11.3.1 ENSEAM® TYPICAL ROOF DETAILS

Figure 11.3.1.1:

Typical Roof Cladding Setout - Unsupported ENSEAM® - Plan View - E04-09

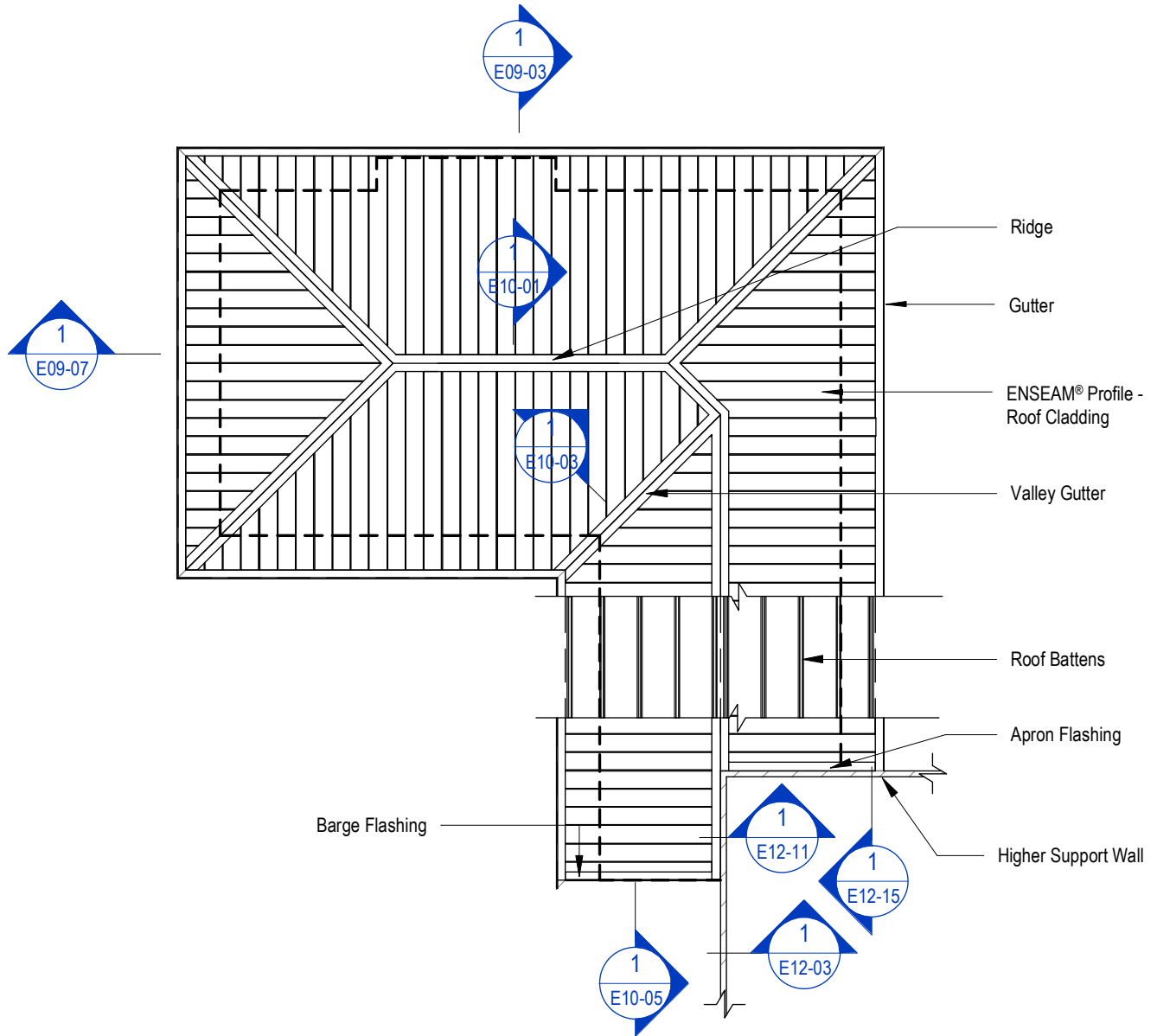

Figure 11.3.1.2:

Top of Wall Eave Detail - Zero Overhang - Unsupported ENSEAM® - Vertical Fix - E09-03

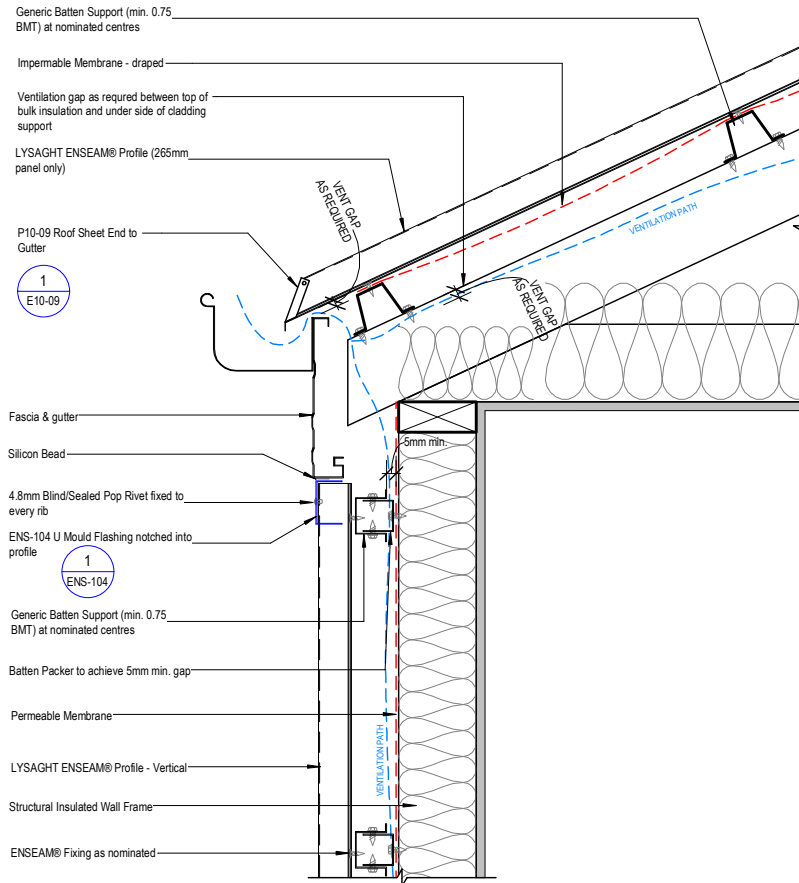

Figure 11.3.1.3:

Top of Wall Eave Detail - Overhang - Unsupported ENSEAM® - Vertical Fix - E09-07

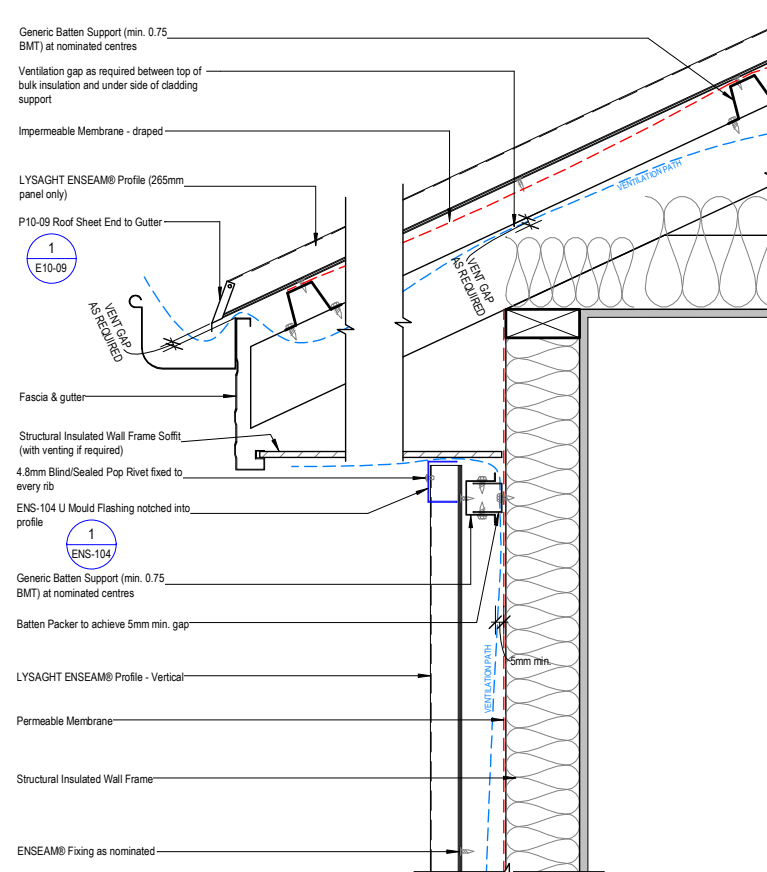

Figure 11.3.1.4:

Ridge Detail - Unsupported ENSEAM® Panel - E10-01

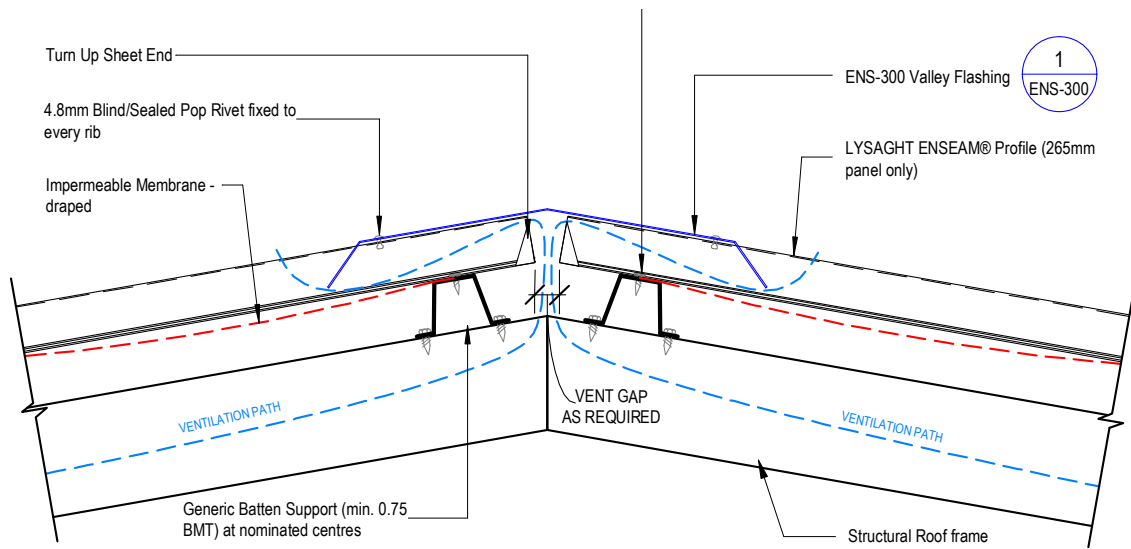

Figure 11.3.1.5:

Valley Detail - Unsupported ENSEAM® Panel - E10-03

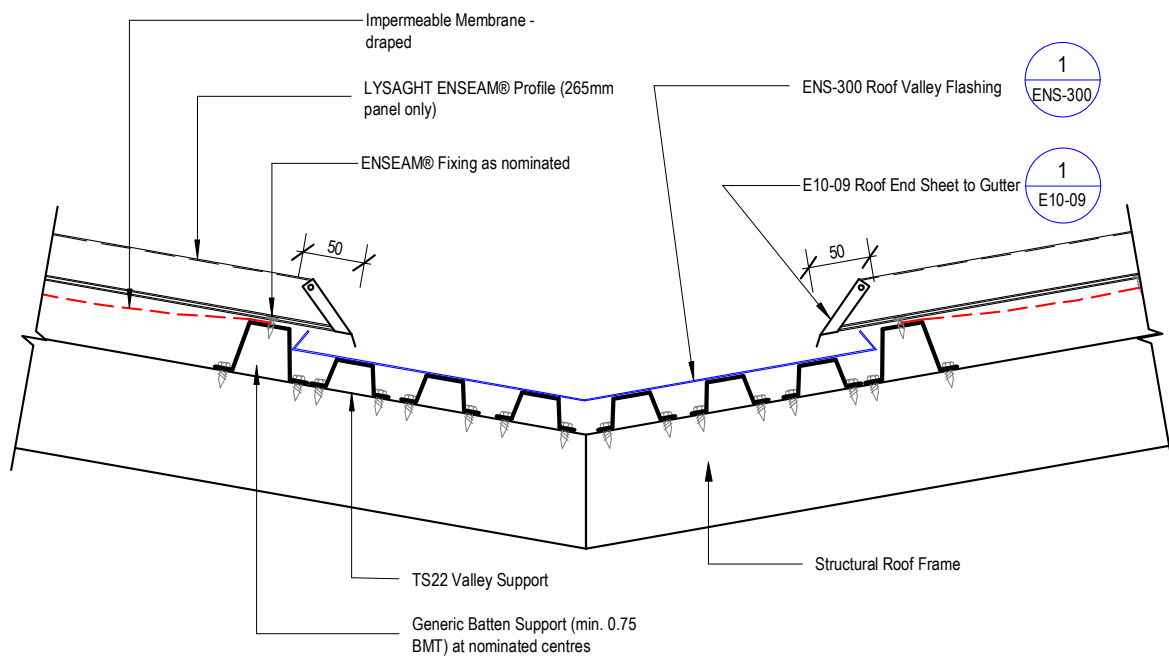

Figure 11.3.1.6:

Gable Detail - Unsupported ENSEAM® Roof and Wall - Vertical Fix - E10-05

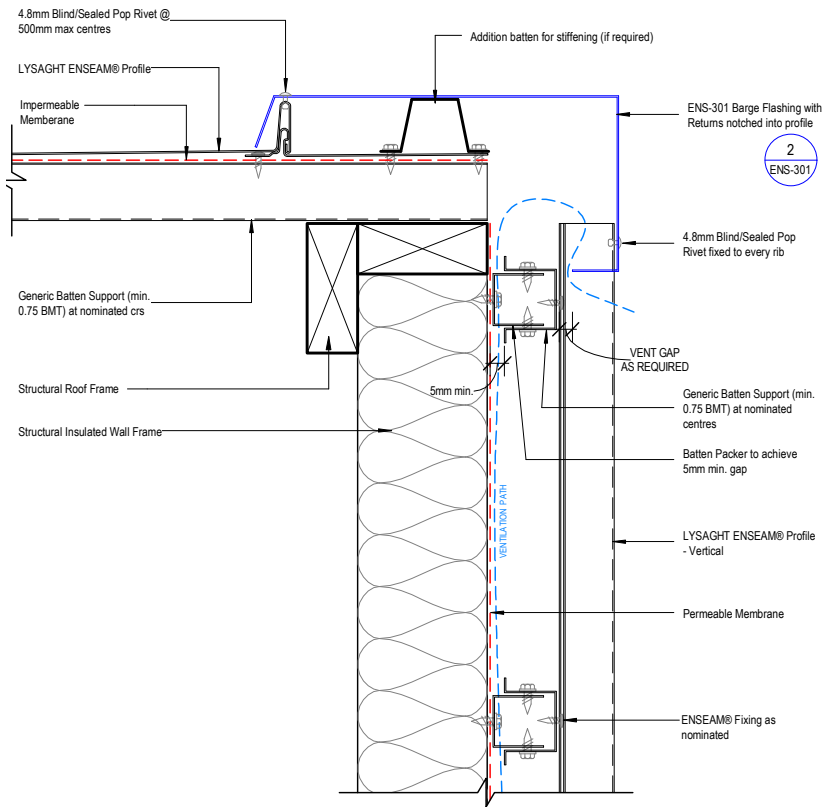

Figure 11.3.1.7:

Parapet Wall Detail - Unsupported ENSEAM® Panel - Vertical Fix - E12-03

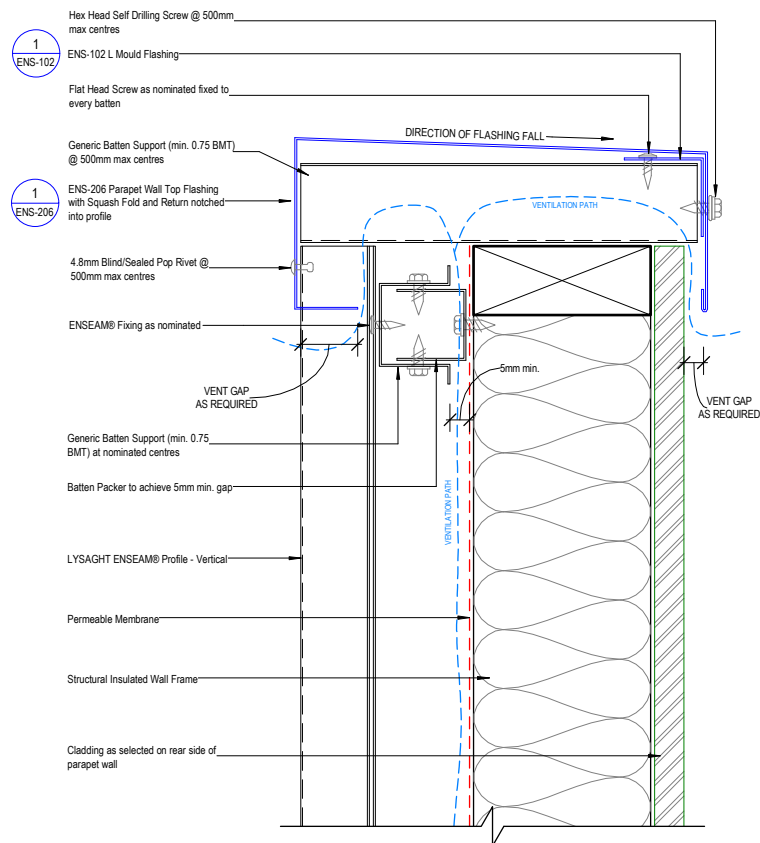

Figure 11.3.1.8:

ENSEAM® Vertical Fix wall to ENSEAM® roof - Unsupported - Side View - E12-11

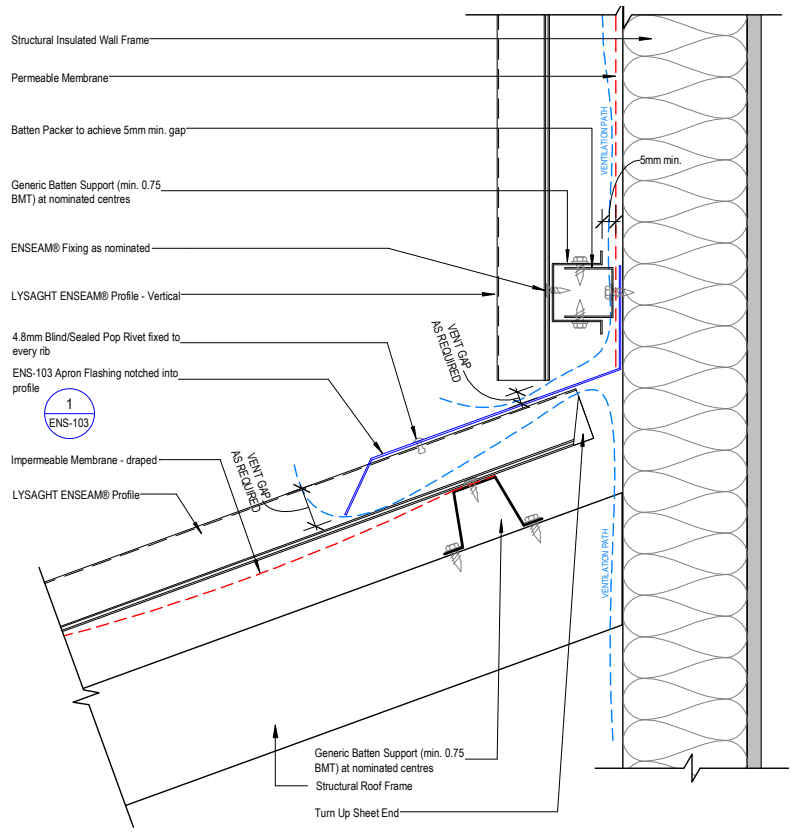
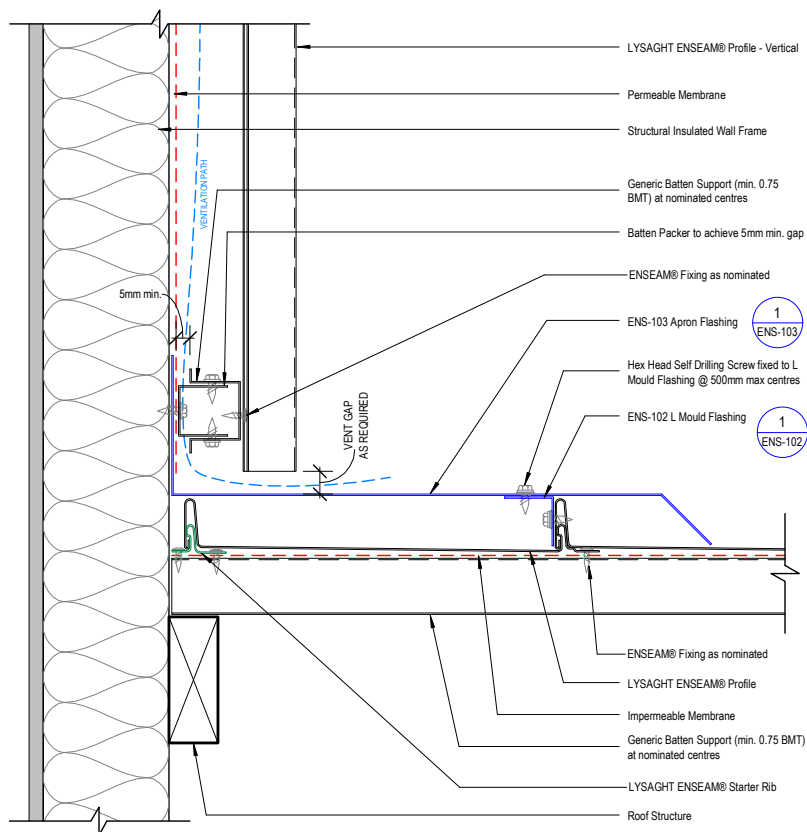

Figure 11.3.1.9:

ENSEAM® Vertical Fix Wall to ENSEAM® Roof - Unsupported - End View - E12-15



11.3.2 ENSEAM® TYPICAL WALL DETAILS - HORIZONTAL FIX

Figure 11.3.2.1:

Typical Wall Cladding Setout - Unsupported ENSEAM® Panel Horizontal Fix - Plan View - E04-01

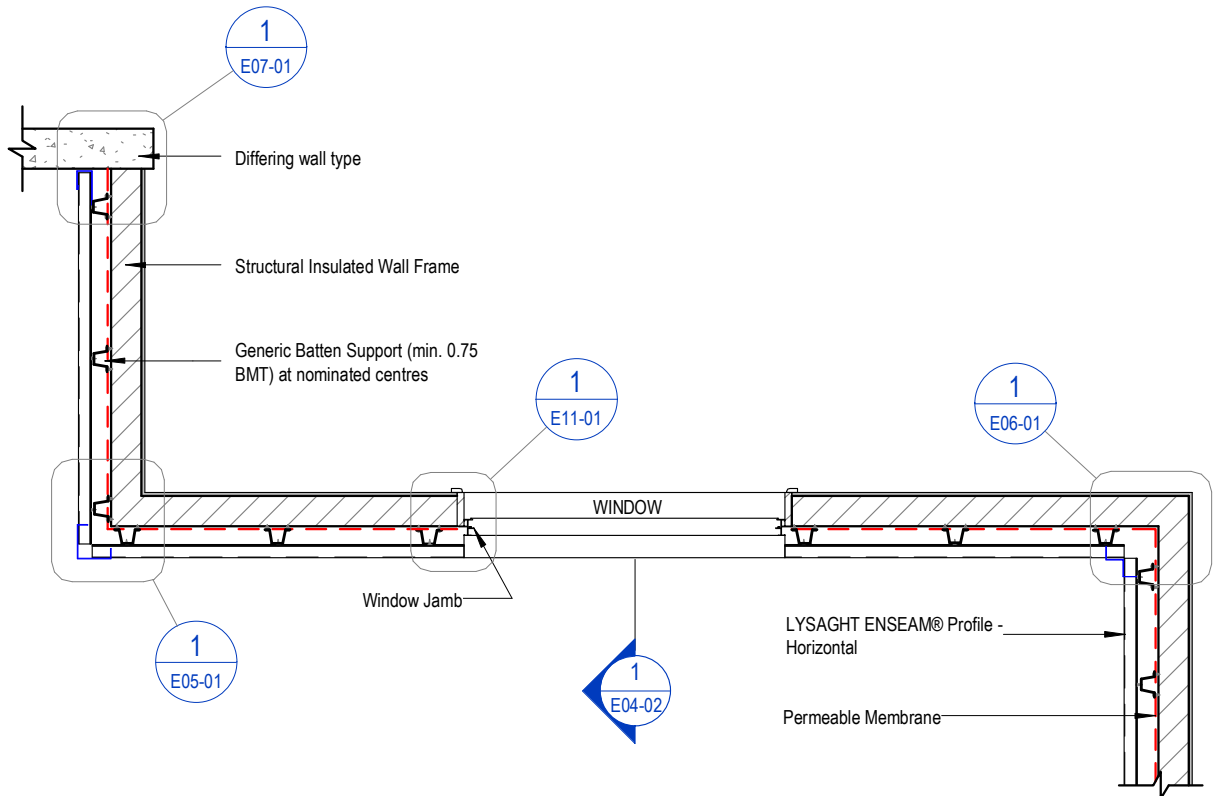

Figure 11.3.2.2:

Typical Wall Cladding Setout - Unsupported ENSEAM® - Horizontal Fix - Sectional View - E04-02

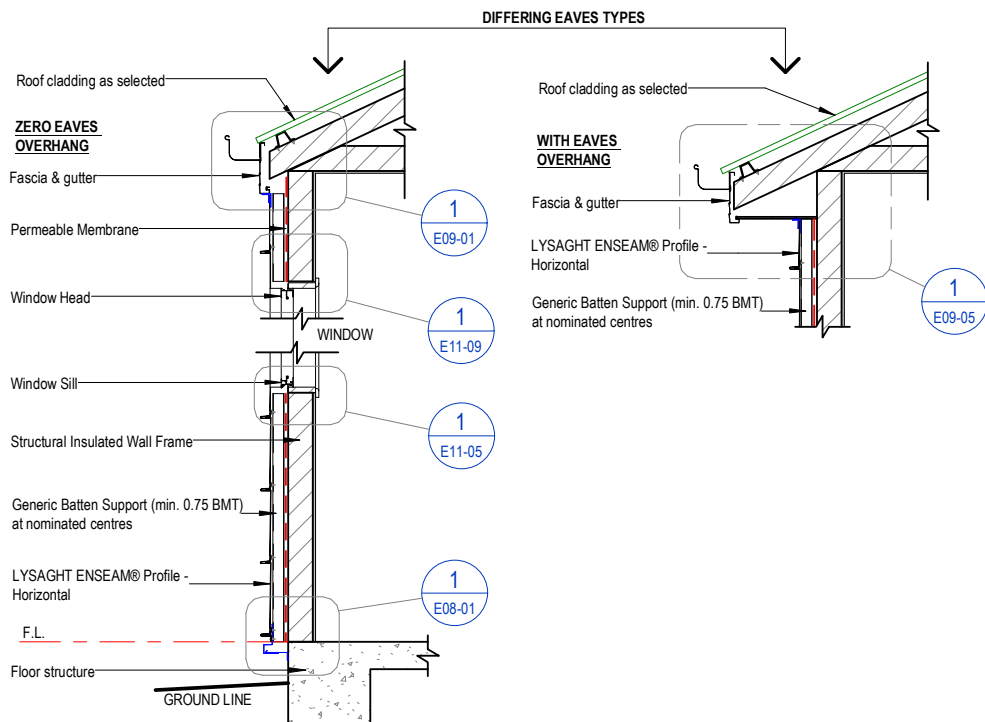

Figure 11.3.2.3:

External Corner Detail - Unsupported ENSEAM® Panel - Horizontal Fix - E05-01

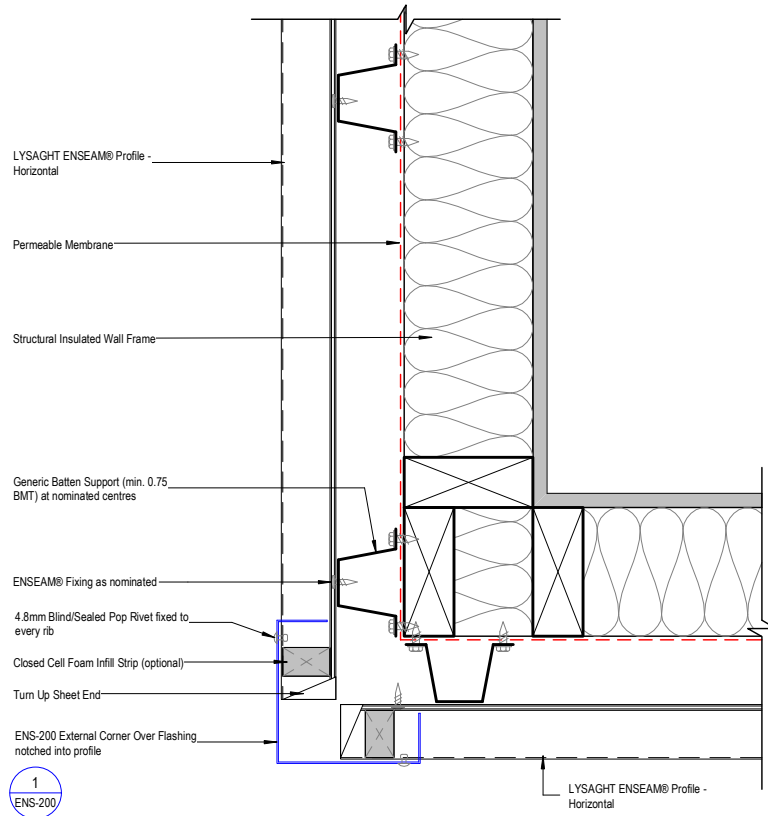

Figure 11.3.2.4:

Internal Corner Detail - Unsupported ENSEAM® Panel - Horizontal Fix - E06-01

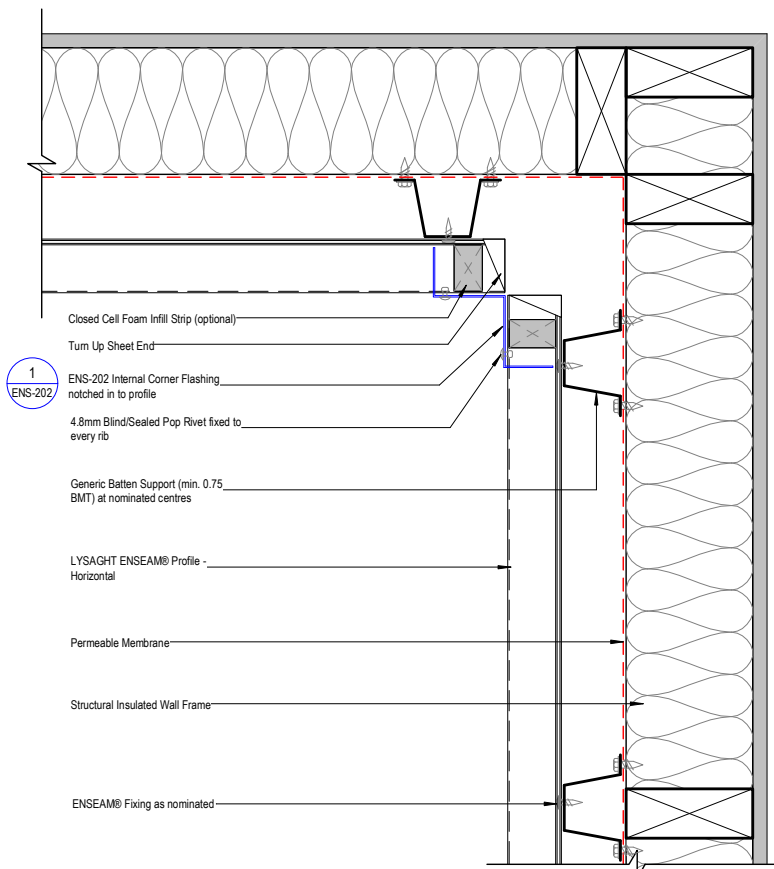

Figure 11.3.2.5:

Wall Closure Detail - Unsupported ENSEAM® Panel - Horizontal Fix - E07-01

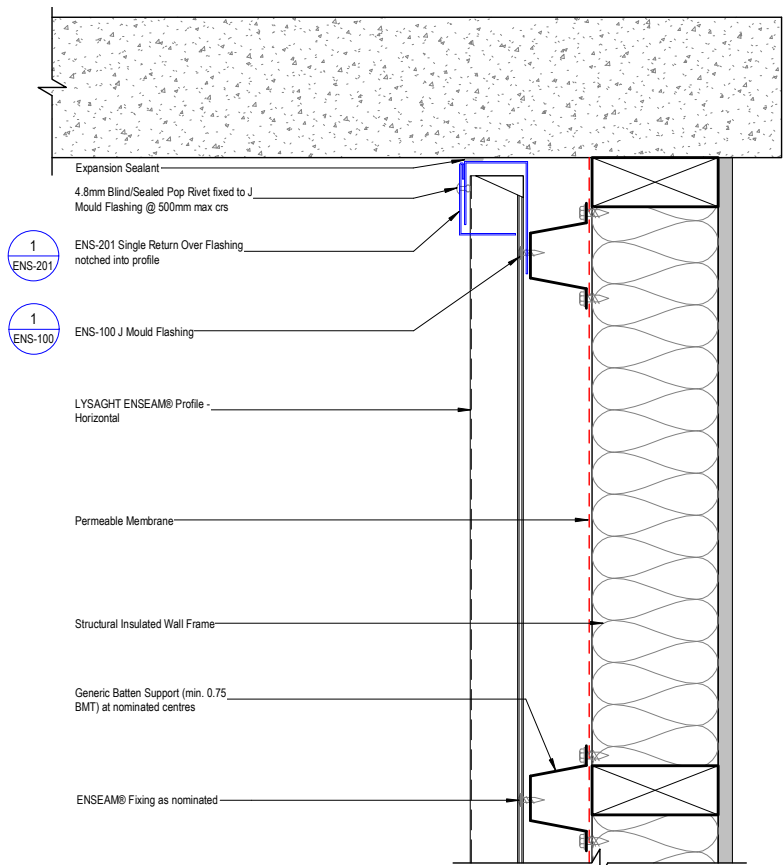

Figure 11.3.2.6:

Window Jamb Detail - Unsupported ENSEAM® Panel - Horizontal Fix - E11-01

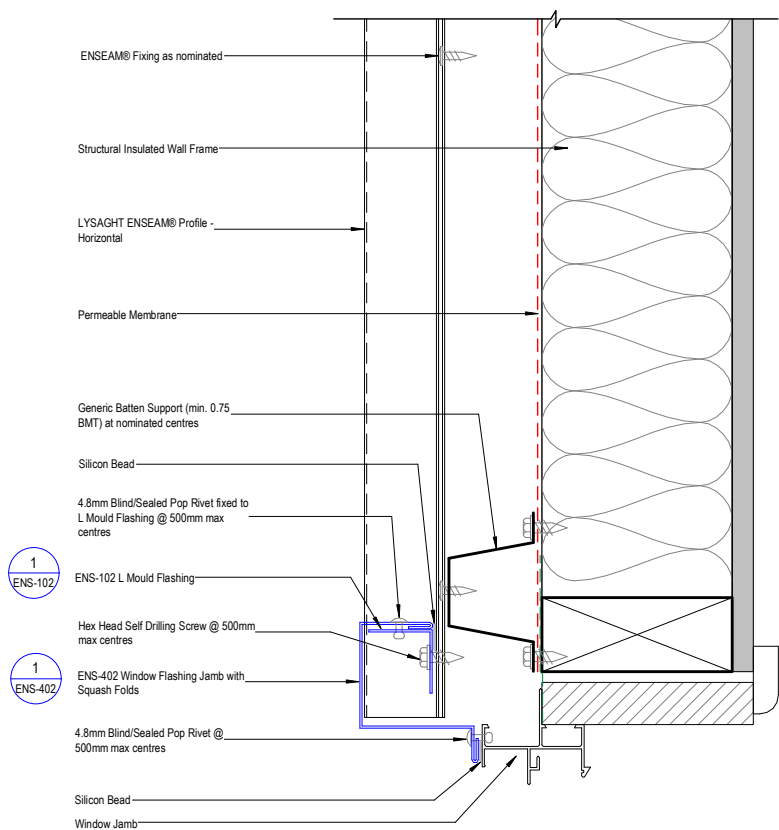

Figure 11.3.2.7:

Wall Base Detail - Unsupported ENSEAM® Panel - Horizontal Fix - E08-01

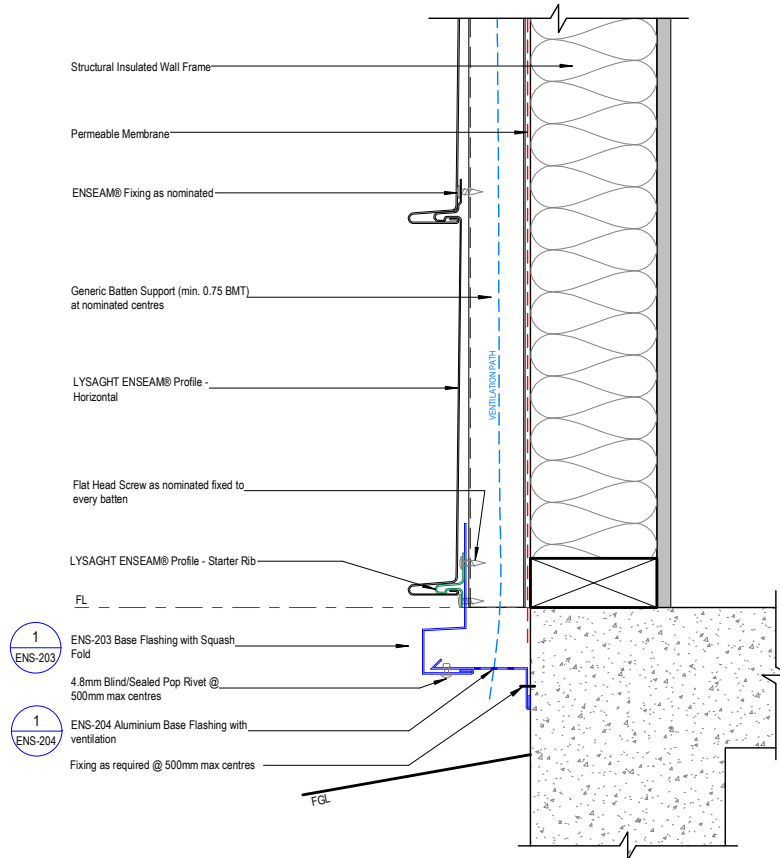

Figure 11.3.2.8:

Top of Wall - Zero Overhang - Unsupported ENSEAM® - Horizontal Fix - E09-01

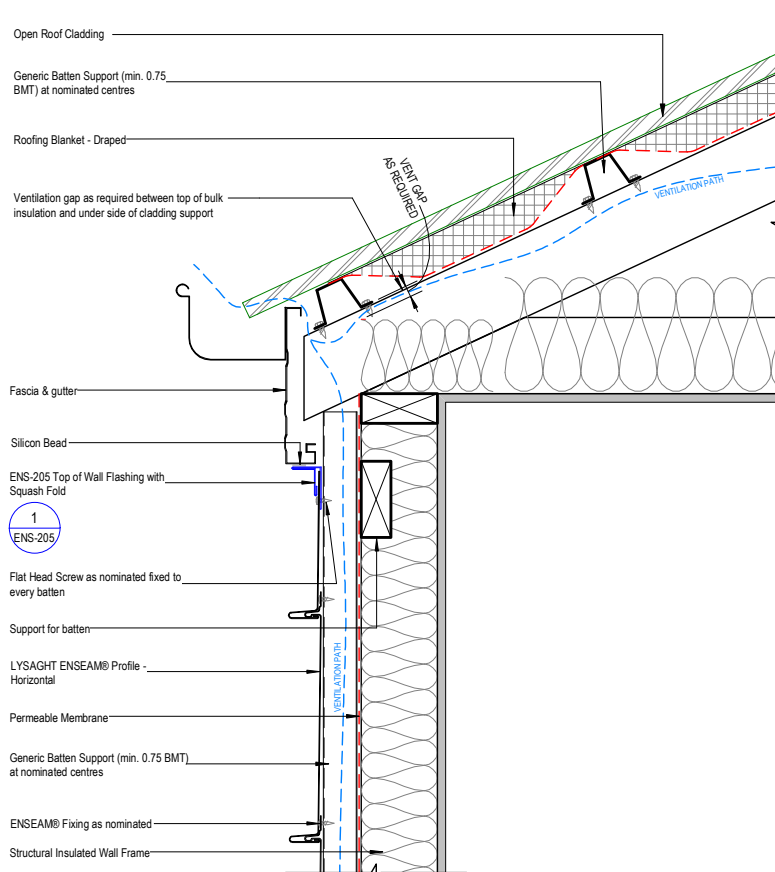

Figure 11.3.2.9:

Top of Eave Detail - Overhang - Unsupported ENSEAM® Panel - Horizontal Fix - E09-05

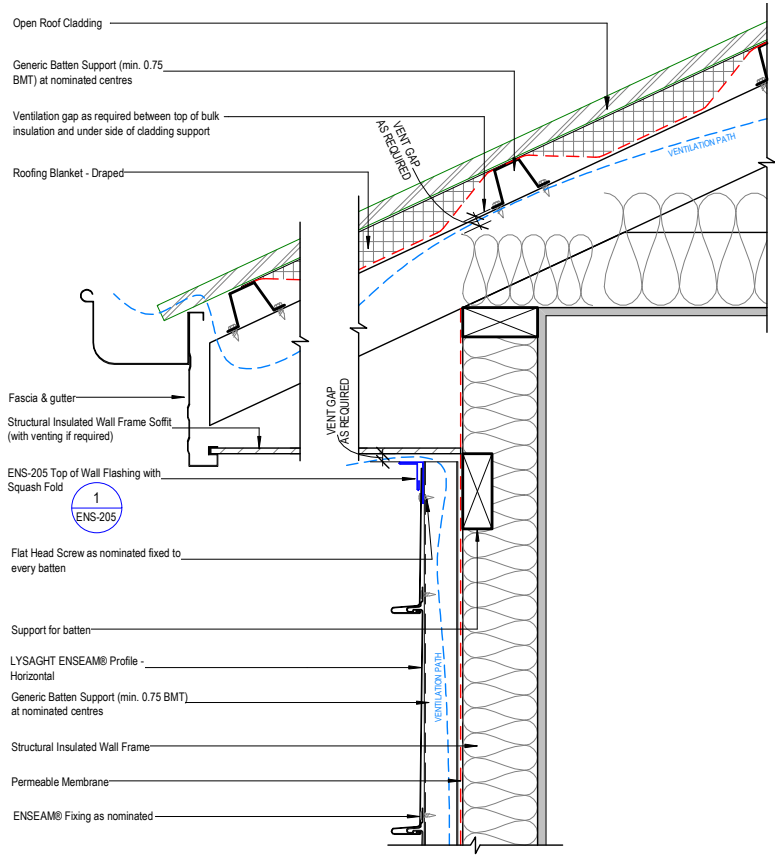

Figure 11.3.2.10:

Window Sill Detail - Unsupported ENSEAM® Panel - Horizontal Fix - E11-05

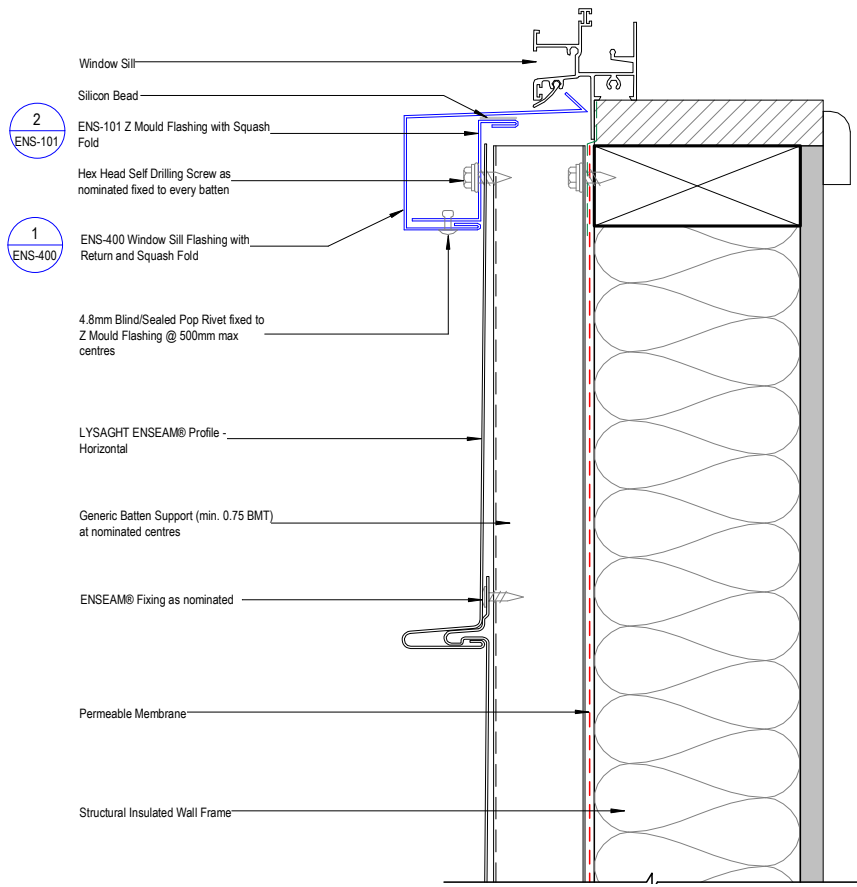
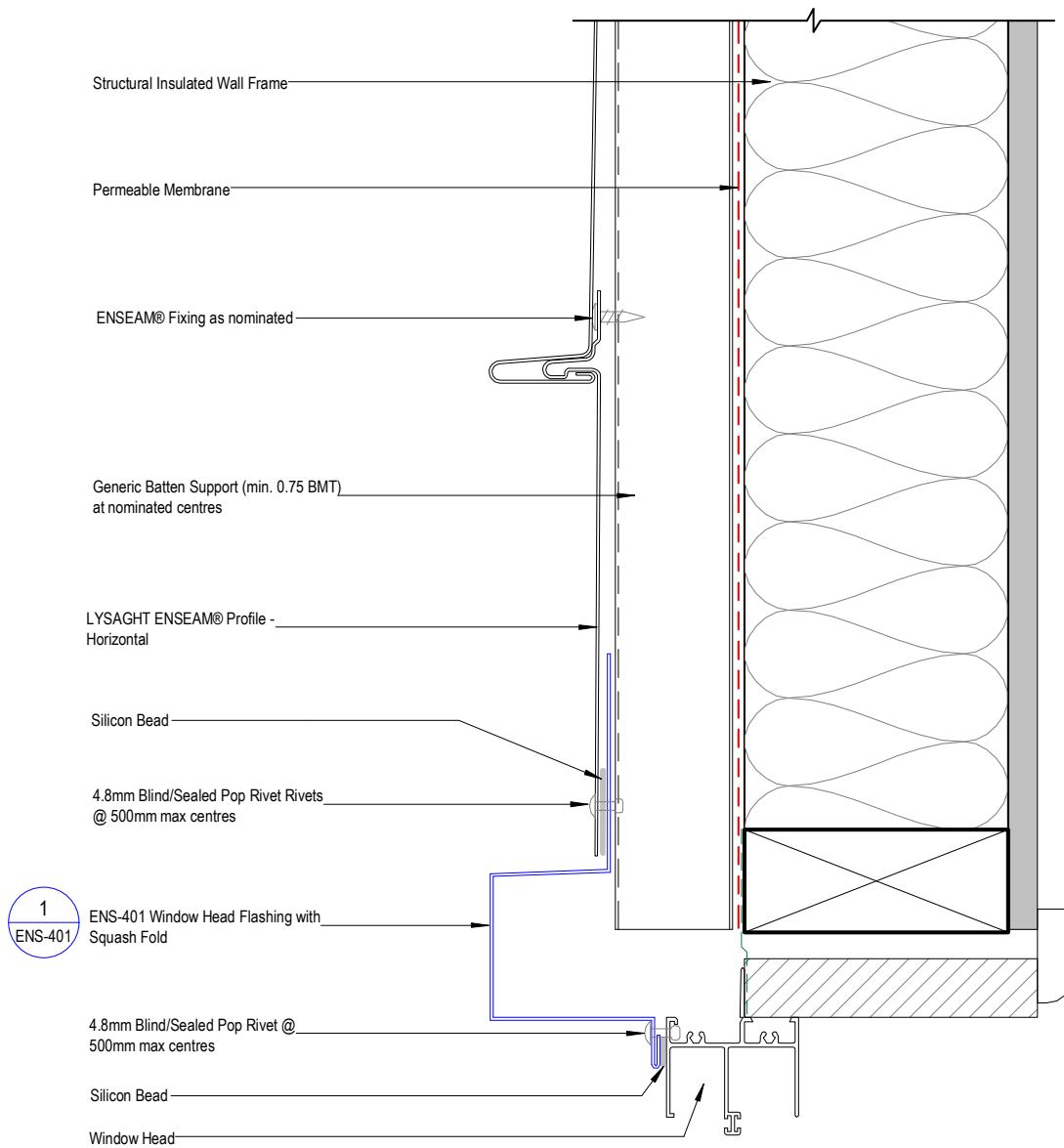

Figure 11.3.2.11:

Window Head Detail - Unsupported ENSEAM® Panel - Horizontal Fix - E11-09



11.3.3 ENSEAM® TYPICAL WALL DETAILS - VERTICAL FIX

Figure 11.3.3.1:

Typical Wall Cladding Setout - Unsupported ENSEAM® Vertical Fix - Plan View - E04-05

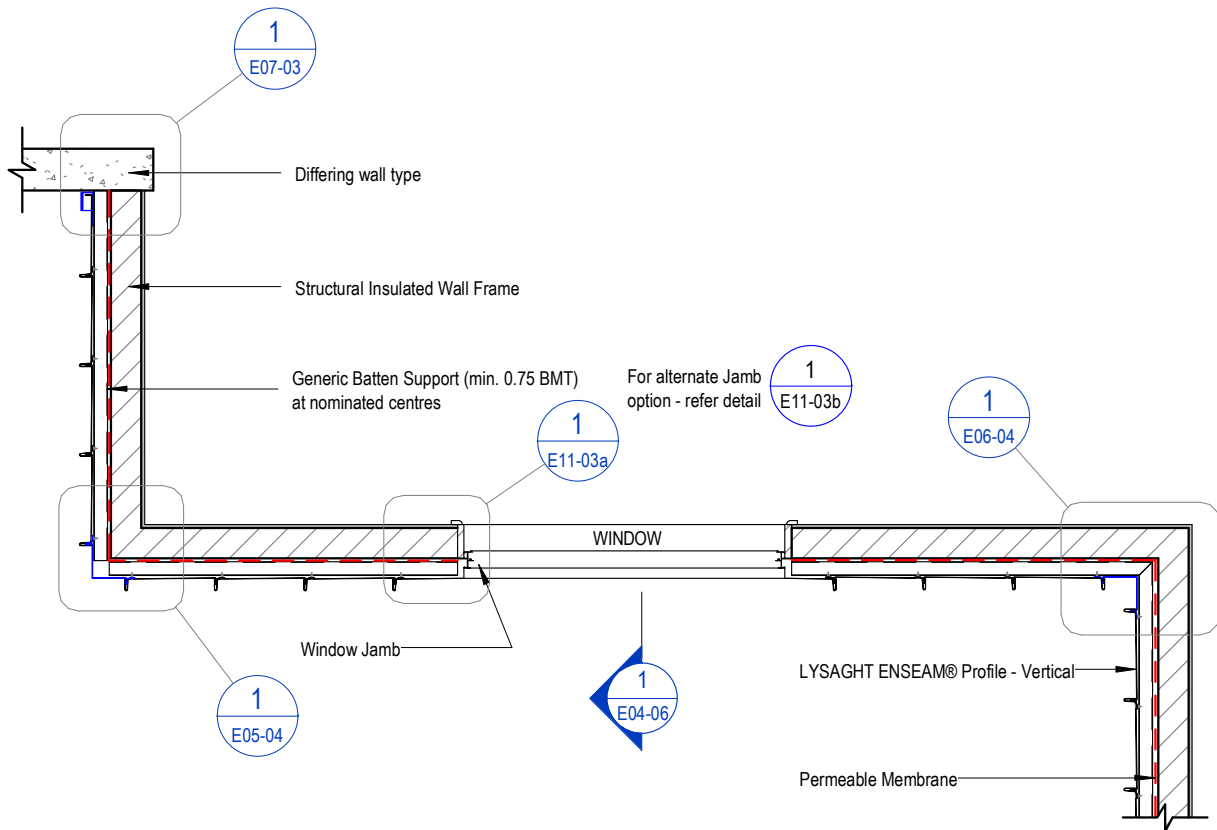

Figure 11.3.3.2:

Typical Wall Cladding Setout - Unsupported ENSEAM® - Vertical Fix - Sectional View - E04-06

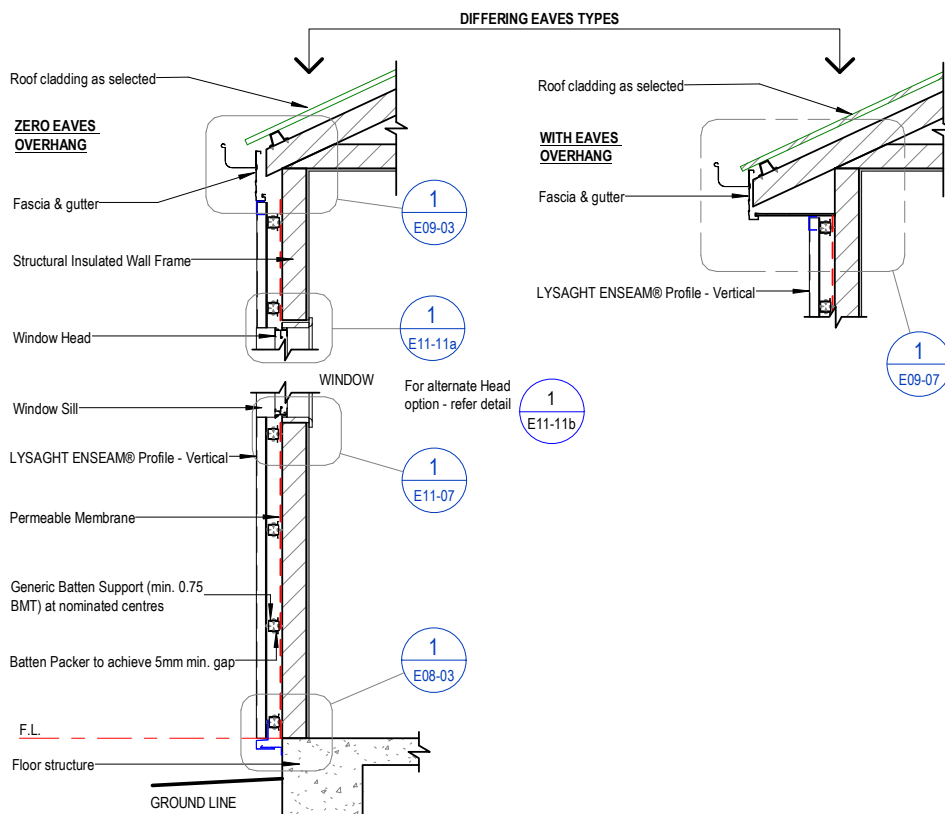

Figure 11.3.3.3:

External Corner Detail - Unsupported ENSEAM® Panel - Vertical Underlap Underlap - E05-04

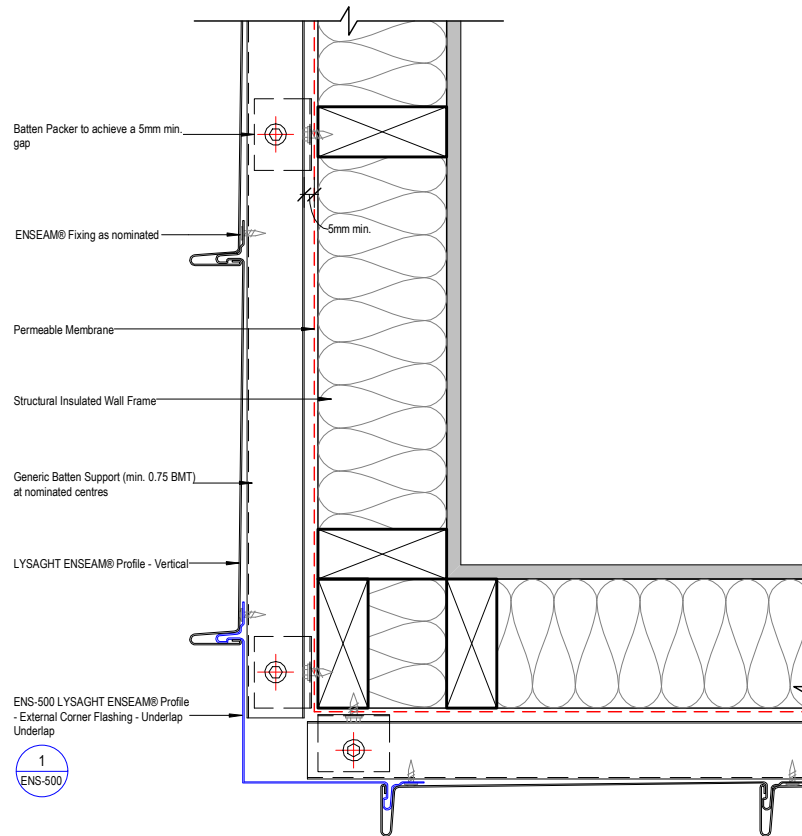

Figure 11.3.3.4:

Internal Corner Detail - Unsupported ENSEAM® Panel - Vertical Underlap Underlap - E06-04

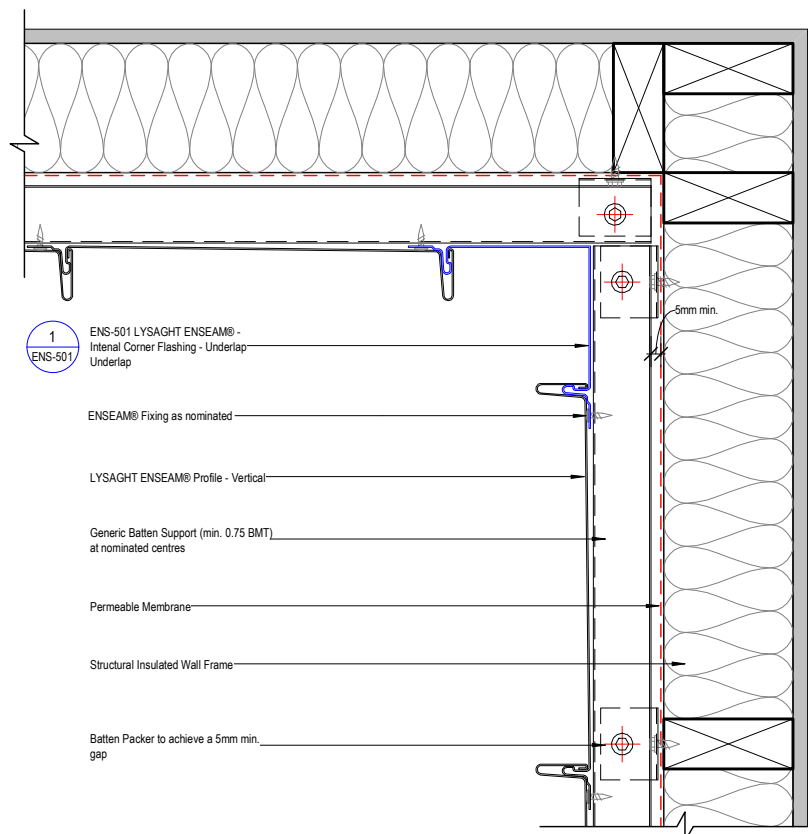

Figure 11.3.3.5:

Wall Closure Detail - Unsupported ENSEAM® Panel - Vertical Fix - E07-03

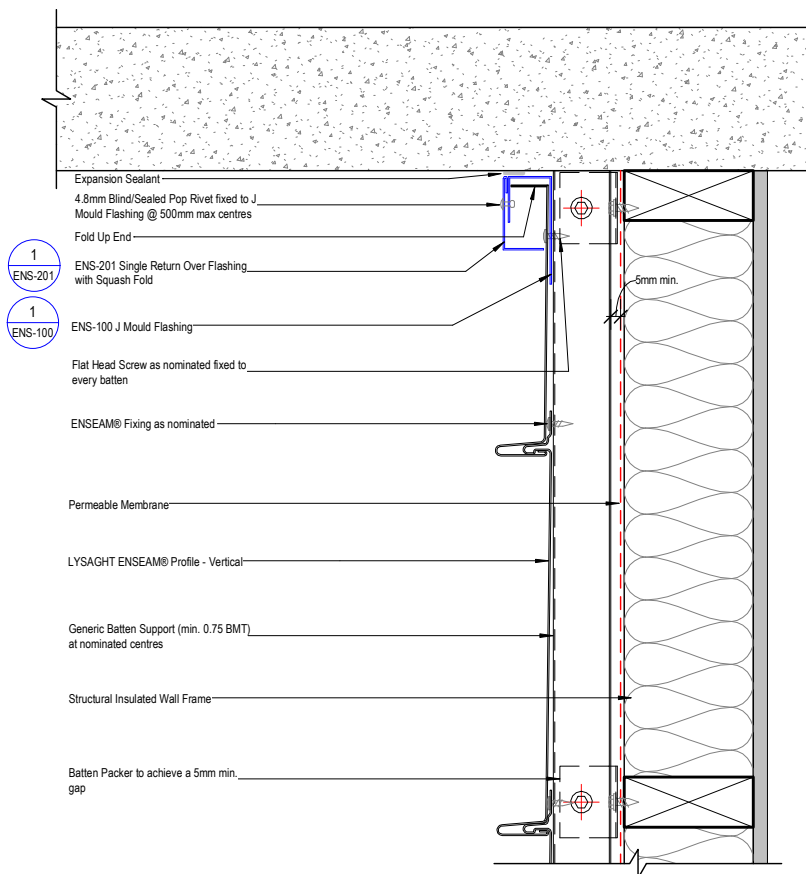

Figure 11.3.3.6:

Window Jamb Detail - Unsupported ENSEAM® Panel - Vertical Fix Option 1 - E11-03a

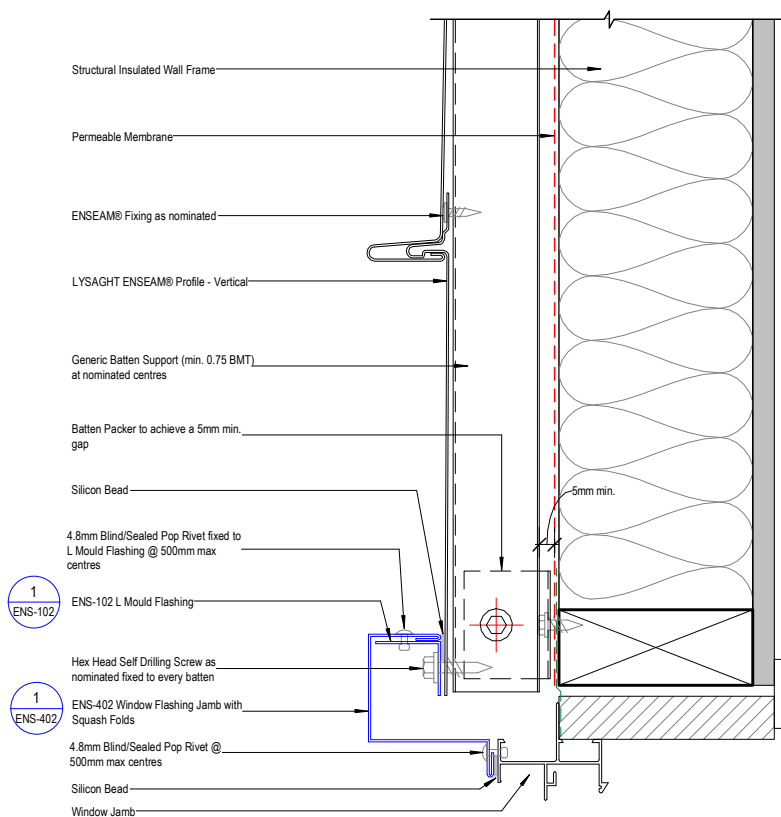

Figure 11.3.3.7:

Window Jamb Detail - Unsupported ENSEAM® Panel - Vertical Fix Option 2 - E11-03b

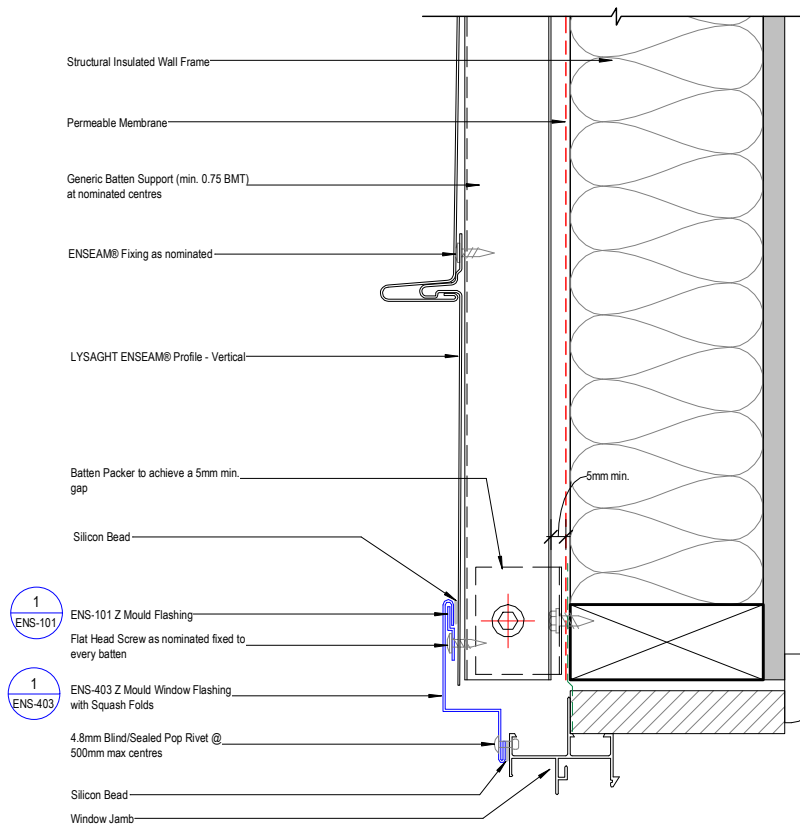

Figure 11.3.3.8:

Wall Base Detail - Unsupported ENSEAM® Panel - Vertical Fix - E08-03

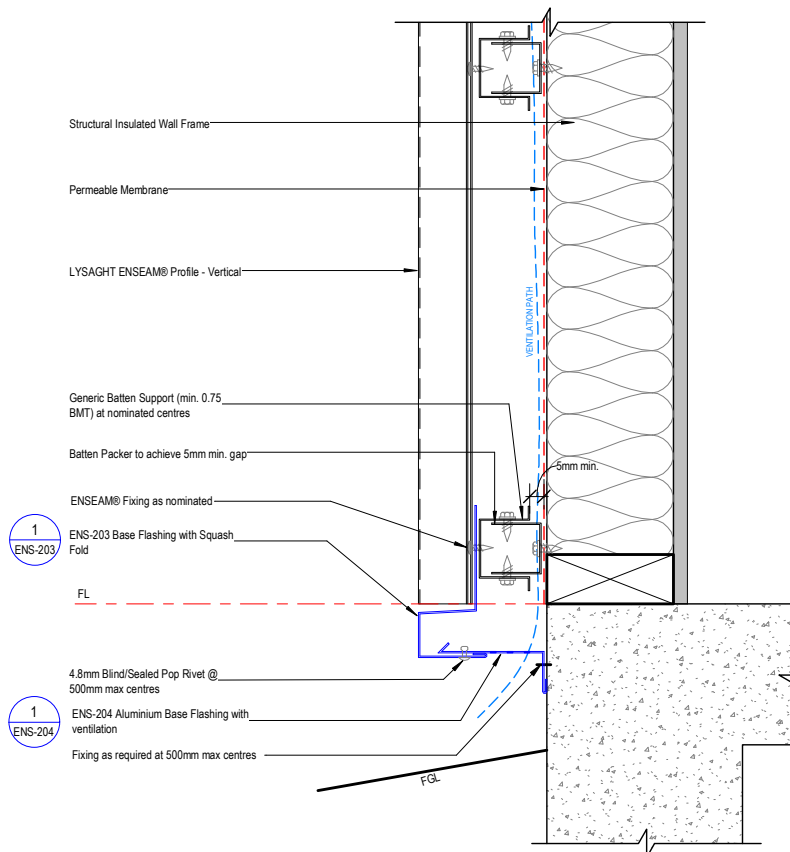

Figure 11.3.3.9:

Top of Wall Eave Detail - Zero Overhang - Unsupported ENSEAM® Panel - Vertical Fix - E09-03

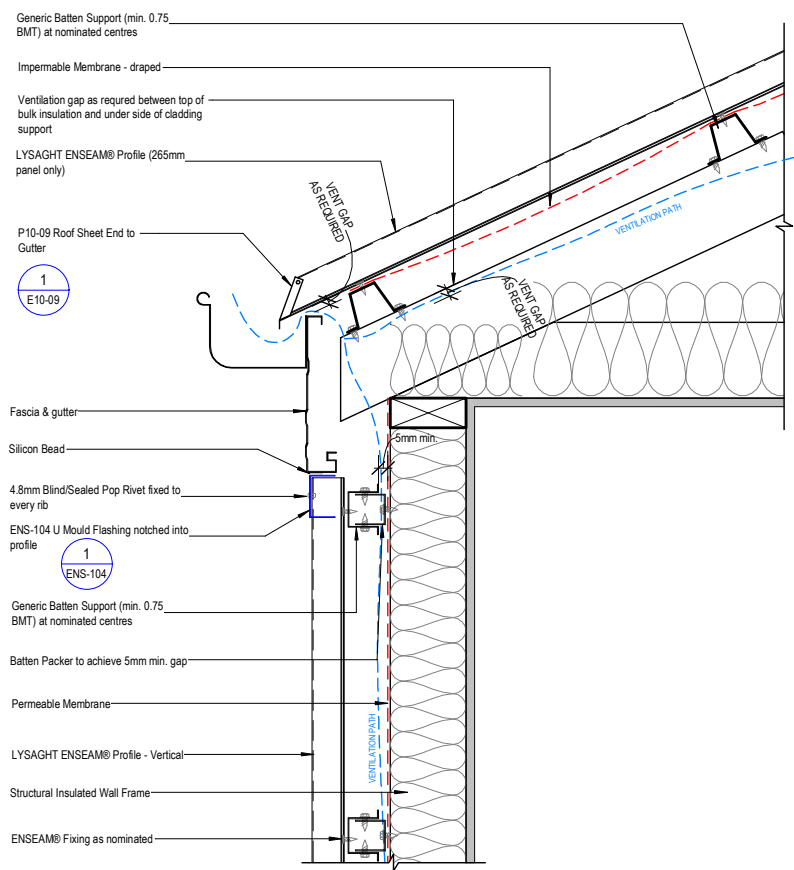

Figure 11.3.3.10:

Top of Wall Eave Detail - Overhang - Unsupported ENSEAM® Panel - Vertical Fix - E09-07

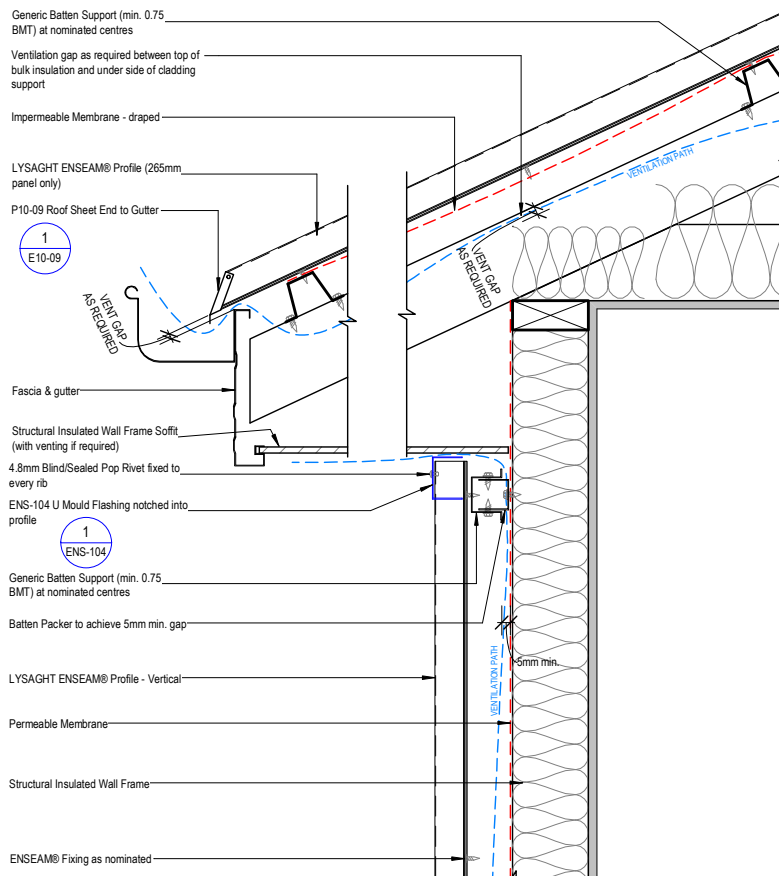

Figure 11.3.3.11:

Window Sill Detail - Unsupported ENSEAM® Panel - Vertical Fix - E11-07

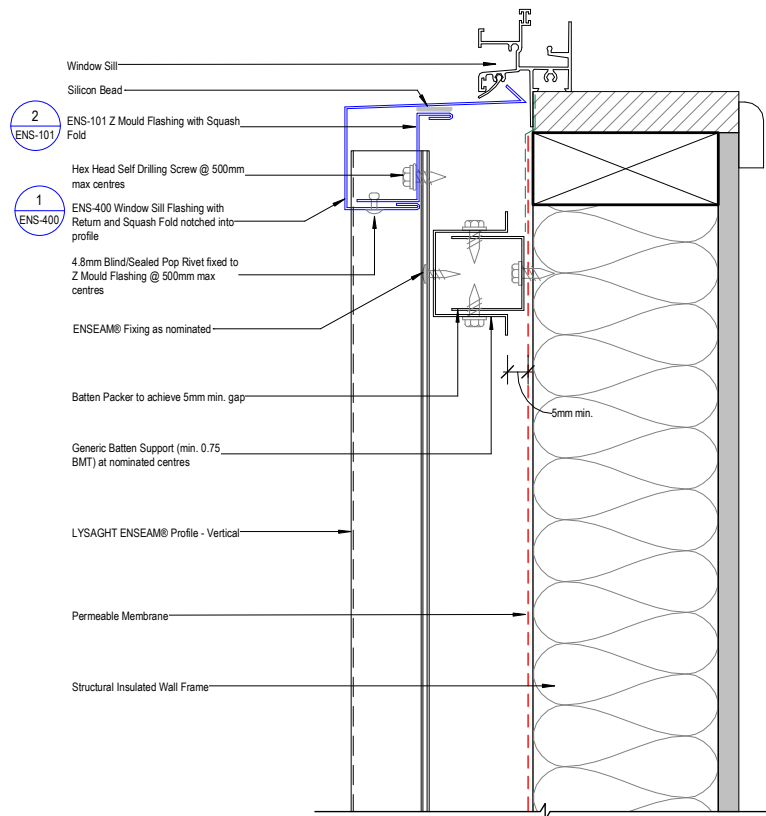

Figure 11.3.3.12:

Window Head Detail - Unsupported ENSEAM® Panel - Vertical Fix Option 1 - E11-11a

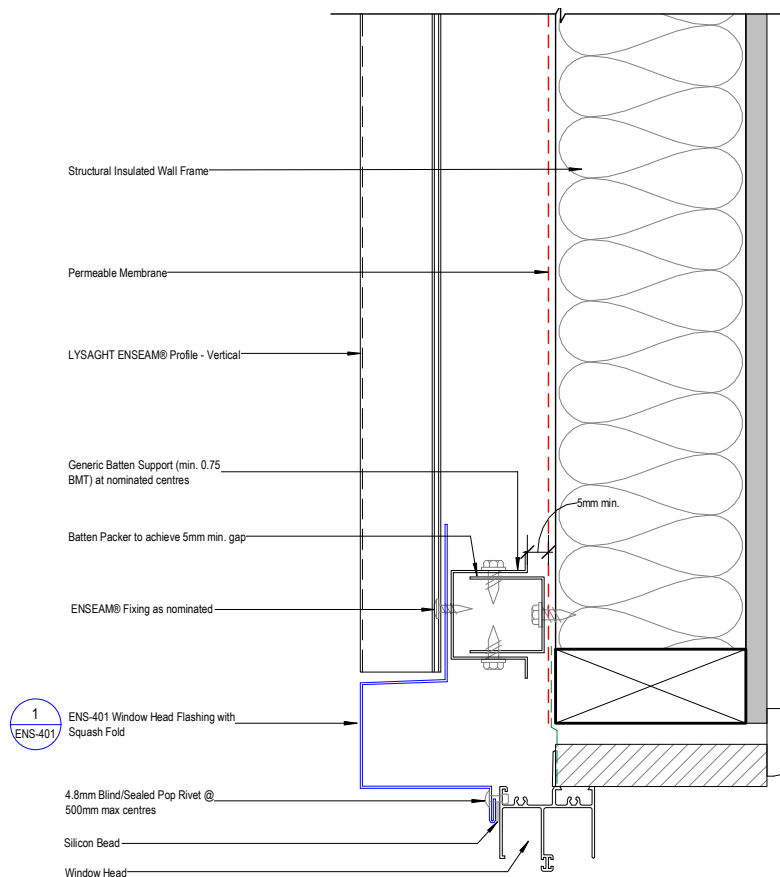
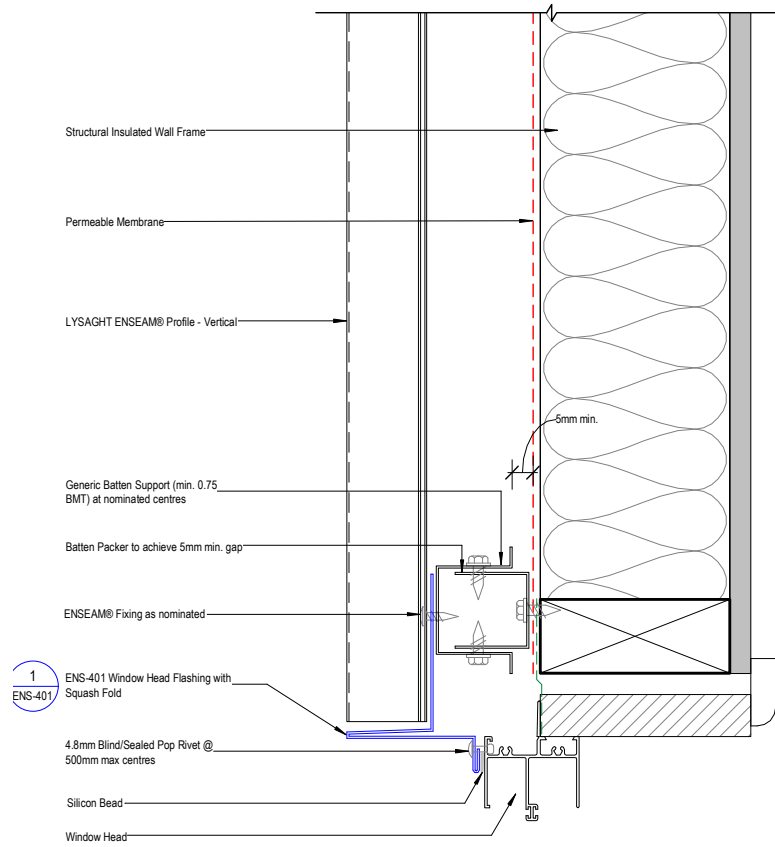

Figure 11.3.3.13:

Window Head Detail - Unsupported ENSEAM® Panel - Vertical Fix Option 2 - E11-11b



11.3.4 ENSEAM® MANSARD ROOF / WALL

Figure 11.3.4.1:

ENSEAM® Mansard Roof - E12-21

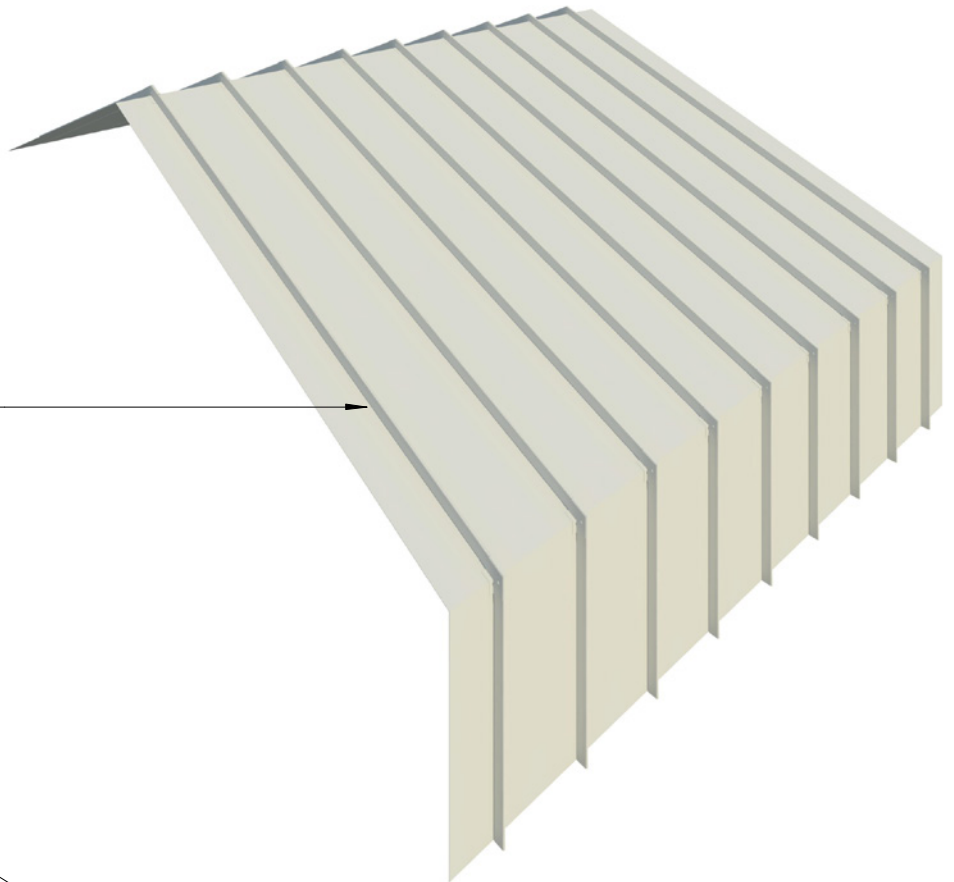

Continuous sheeting. Mansard roof with trays bent and the cut ribs waterproofed with sealed rib caps.

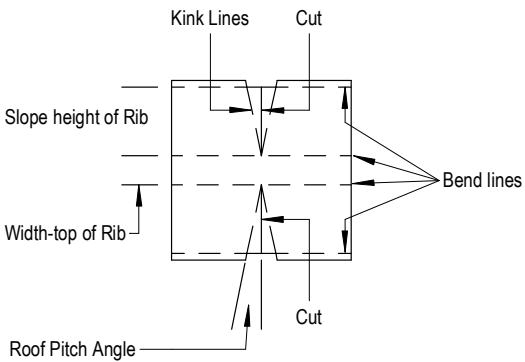

Development Cap

A E12-21 - Development of Cap
1 : 1



Apply recommended sealant inside ends and along bottom of cap. Place in positon over opened rib and fasten with four 4mm blind rivets.

Figure 11.3.4.2:

ENSEAM® Mansard Roof to Wall Connection - E12-22

STEP 1

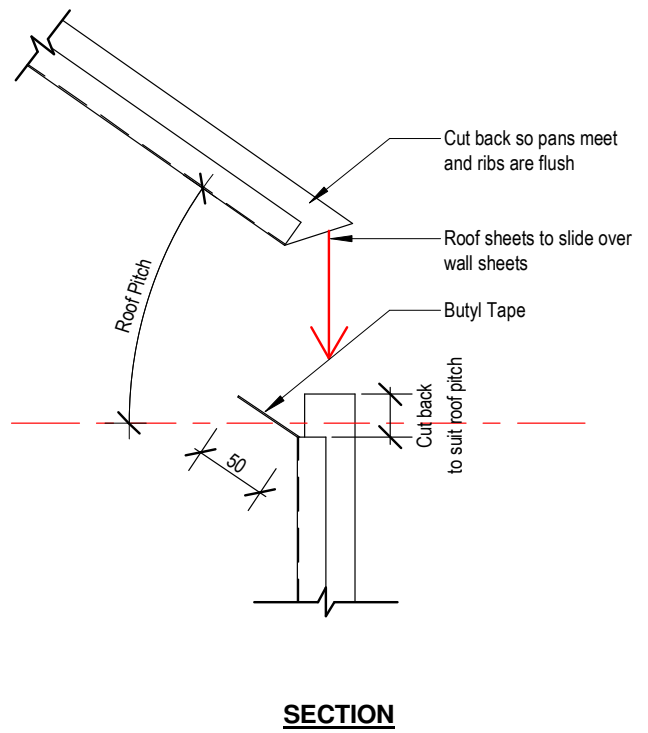
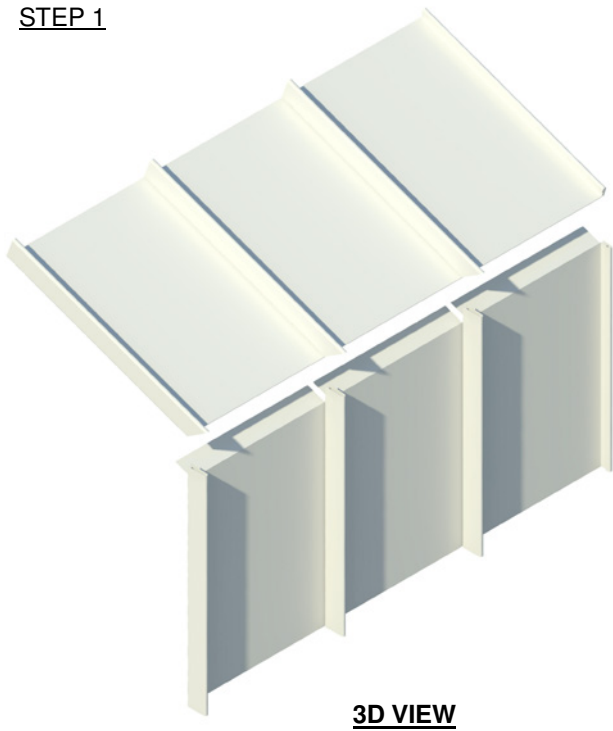

STEP 2

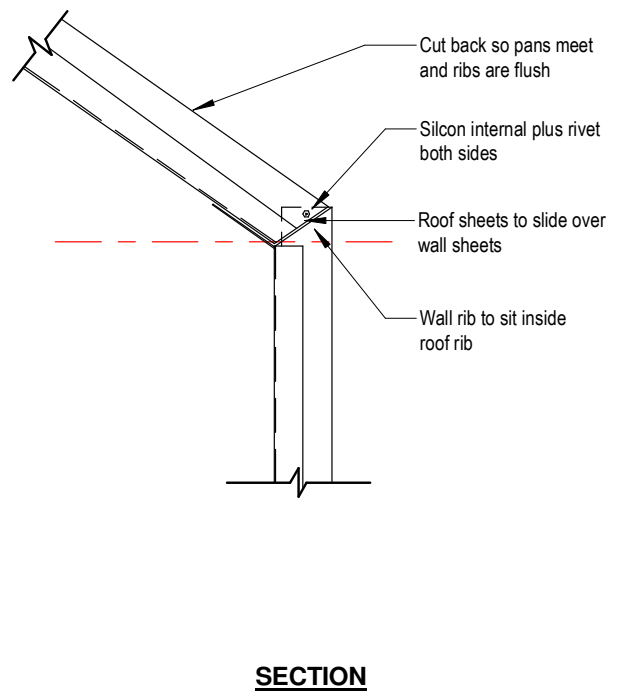
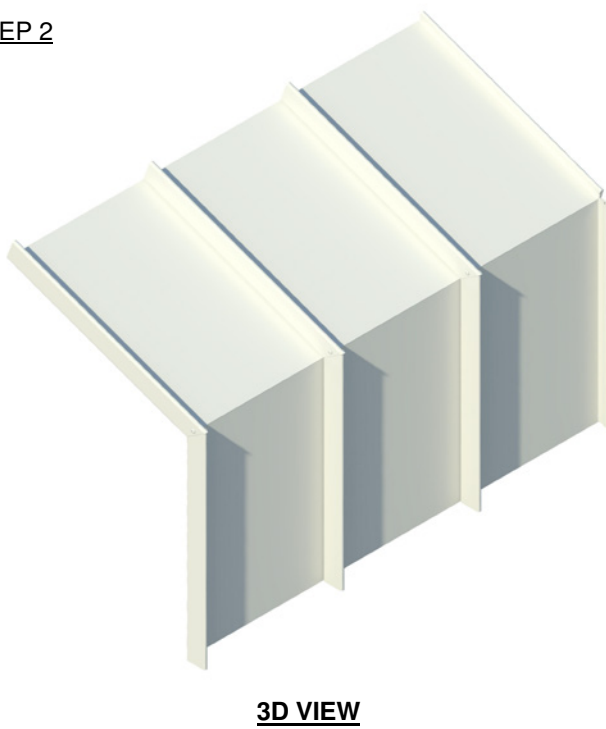

11.3.5 ENSEAM® TYPICAL FLASHINGS

Figure 11.3.5.1:

ENS-100 - J Mould Flashings

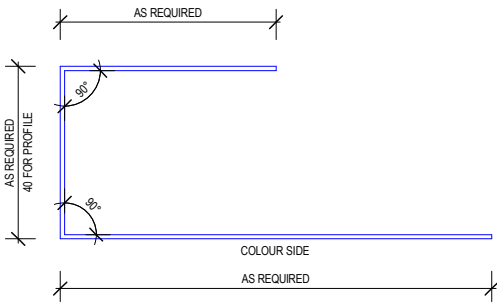

ENS - J Mould Flashing with Squash Fold

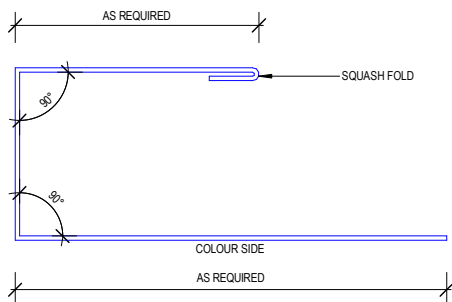
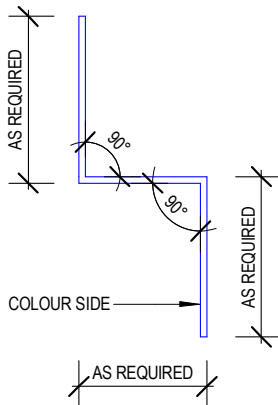

Figure 11.3.5.2:

ENS-101 - Z Mould Flashings



ENS-101 - Z Mould Flashing with Squash Fold

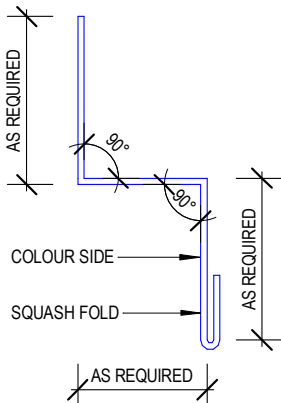
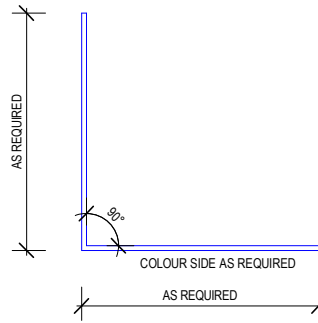
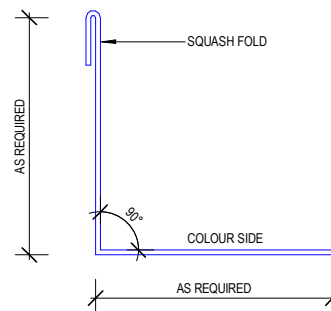

Figure 11.3.5.3:

ENS-102 - L Mould Flashings



ENS-102 - L Mould Flashing with 1 Squash Fold



ENS-102 - L Mould Flashing with Squash Folds

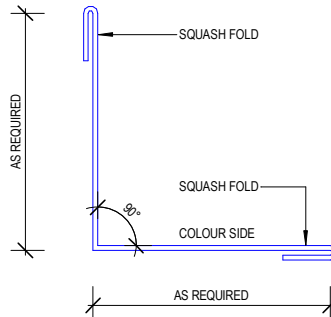
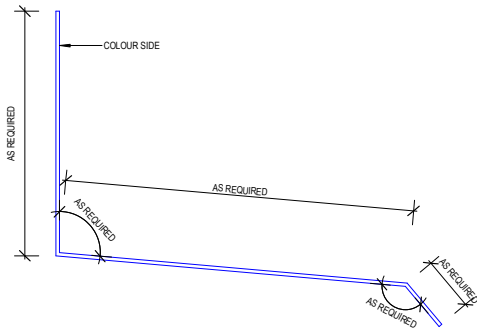

Figure 11.3.5.4:

ENS-103 - Apron Flashings



ENS-103 - Apron Flashing with Squash Fold

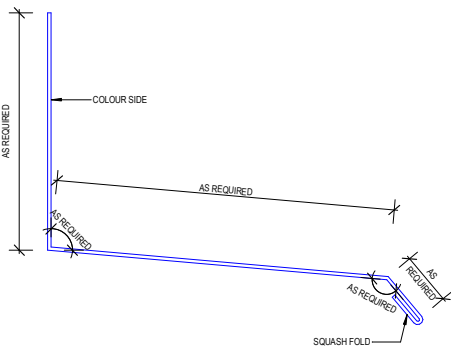

Figure 11.3.5.5:

ENS-104 - U Mould Flashing

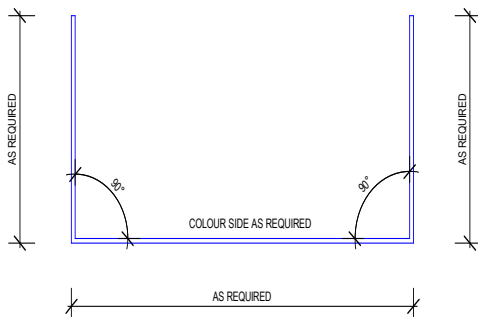

Figure 11.3.5.6:

ENS-200 - External Corner Over Flashing

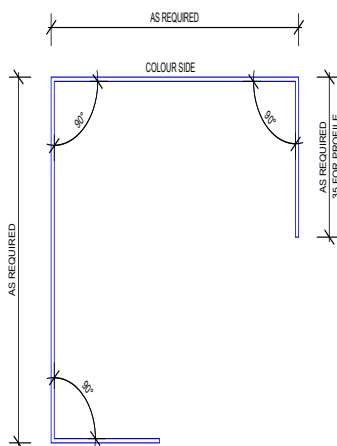

Figure 11.3.5.7:

ENS-201 - Single Return Over Flashing

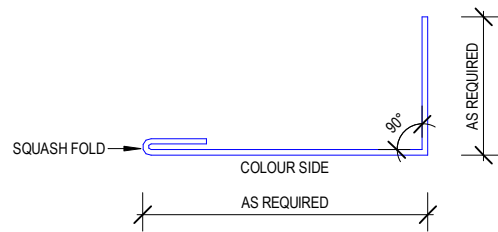

Figure 11.3.5.8:

ENS-202 - Internal Corner Over Flashing

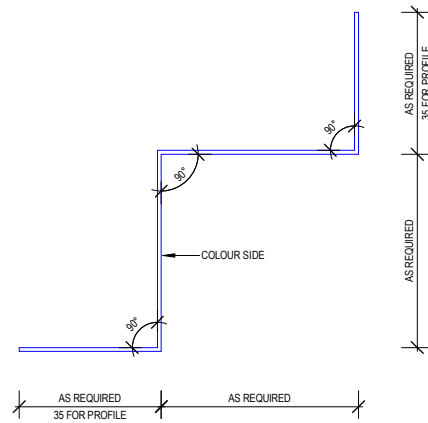
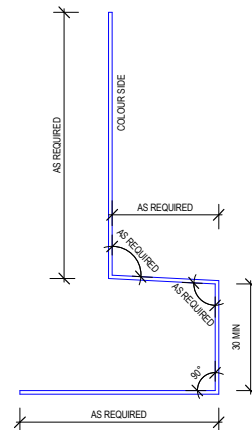

Figure 11.3.5.9:

ENS-203 - Base Flashings



ENS-203 - Base Flashing with Squash Fold

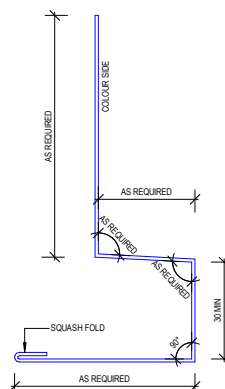

Figure 11.3.5.10:

ENS-204 - Aluminium Base Flashing with Ventilation

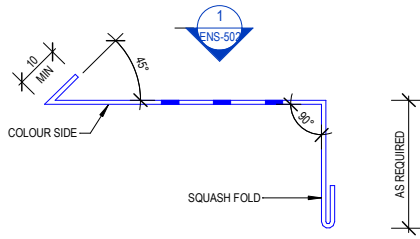

Figure 11.3.5.11:

ENS-205 - Top of Wall Flashing

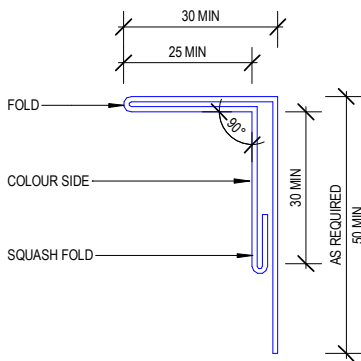
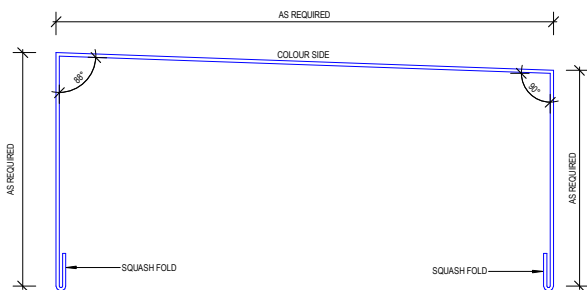

Figure 11.3.5.12:

ENS-206 - Parapet Top Flashing with Squash Folds



LON-206 - Parapet Top Flashing with Squash Fold and return

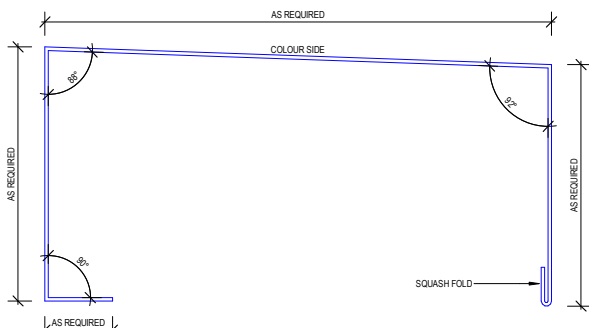

Figure 11.3.5.13:

ENS-300 - Roof Valley Flashing

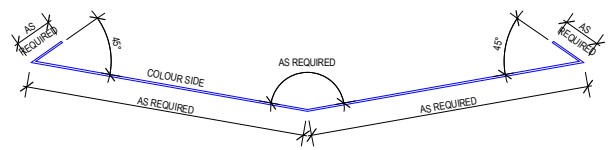
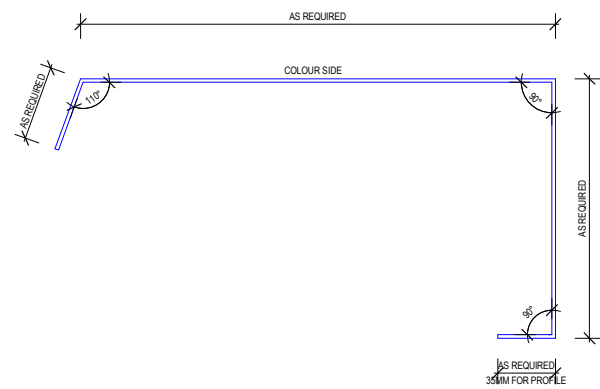

Figure 11.3.5.14:

ENS-301 - Barge Flashing with returns



ENS-301 - Barge Flashing with return and Squash Fold

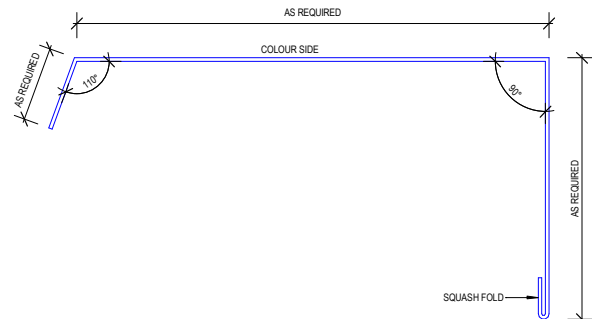

Figure 11.3.5.15:

ENS-302 - Ridge Cap Flashing

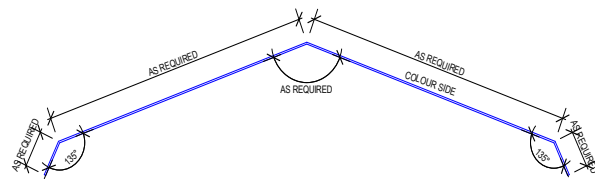

Figure 11.3.5.16:

ENS-400 - Window Sill Flashing with Squash Fold

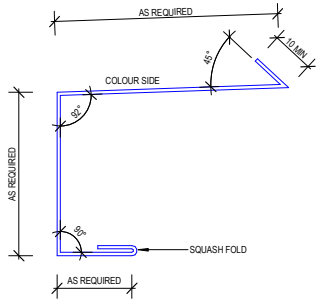

Figure 11.3.5.17:

ENS-401 - Window Head Flashing with Squash Fold

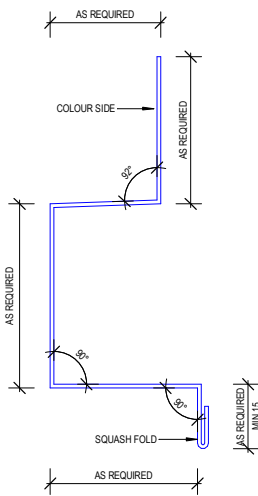

Figure 11.3.5.18:

ENS-402 - Window Jamb Flashing with Squash Folds

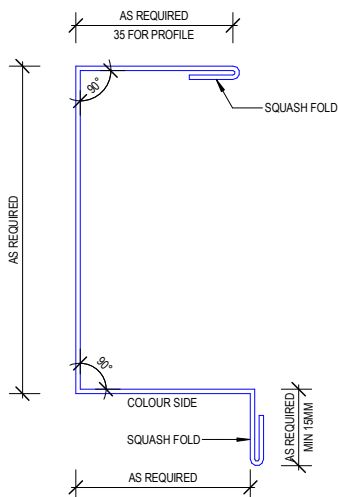

Figure 11.3.5.19:

ENS-403 - Window Z flashing with Squash Fold

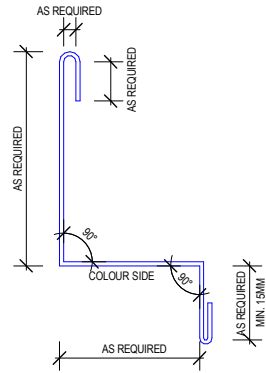
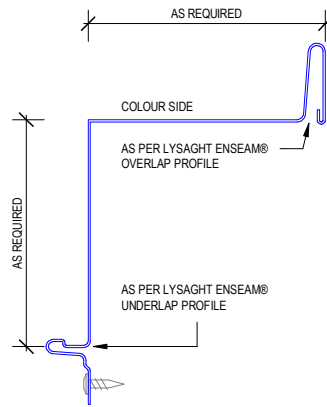

Figure 11.3.5.20:

ENS-500 - External Corner Details - Overlap Underlap



ENS-500 - External Corner Details - Overlap Overlap

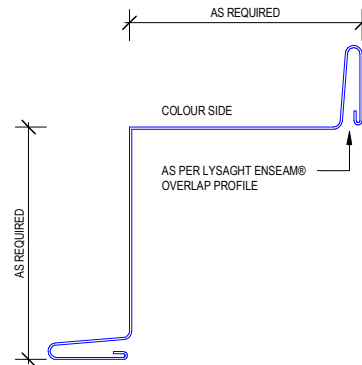
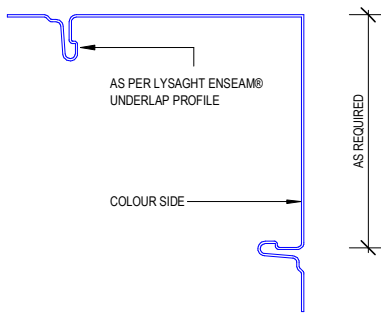
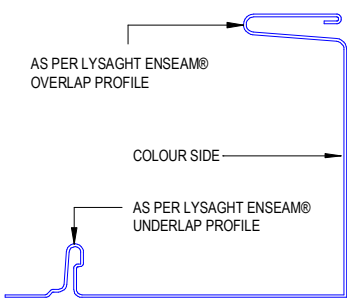

Figure 11.3.5.21:

ENS-501 - Internal Corner Details - Underlap Underlap



ENS-500 - Internal Corner Details - Overlap Underlap



ENS-500 - Internal Corner Details - Overlap Overlap

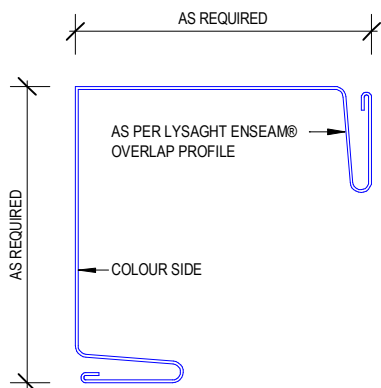

Figure 11.3.5.22:

ENS-502 - Perforation Detail

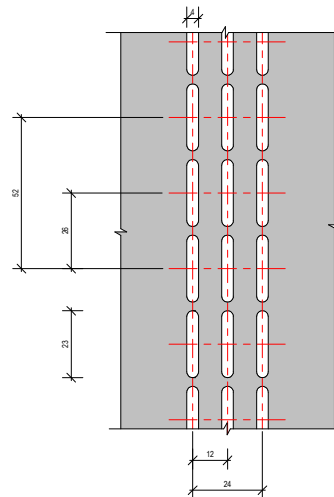
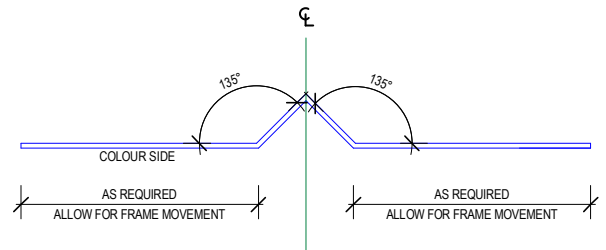

Figure 11.3.5.23:

ENS-503 - Corrosion Resistant Flashing



12.0 SNAPSEAM™ cyclonic roof and wall cladding

SNAPSEAM™ architectural cladding is a concealed fixed flat panel cladding system. SNAPSEAM™ is structurally sound for clip fixed to steel battens and can also be fixed onto conventional supporting substrate such as plywood or fibre cement panels.

The wide flat profile gives a modern architecturally designed premium finish.

12.1 MATERIAL SPECIFICATIONS

Coverage (mm)	265		
Base Metal Thickness (BMT) (mm)	0.55	0.7*	0.75*
Total Coated Thickness⁽¹⁾ (TCT) (mm)	0.6	0.75	0.8
Rib Height (mm)	38		
Sheet Length⁽²⁾ (mm)			
Minimum	500		
Maximum	8,000 ⁽²⁾		
Mass / Unit Length (kg/m)			
ZINCALUME® steel	1.83	2.25	2.41
COLORBOND® steel ⁽¹⁾	1.96	2.29	2.44
Mass / Unit Area (kg/m²)			
ZINCALUME® steel	6.91	8.50	9.09
COLORBOND® steel ⁽¹⁾	7.02	8.65	9.21
Minimum Yield Strength	300 (G300)		
Coating Class (See Base Material for detail)	AM125 - ZINCALUME® steel AM100 - COLORBOND® steel AM100 - COLORBOND® Metallic steel AM150 - COLORBOND® Ultra steel		
Tolerance	Sheet length: ±3mm Cover width: ±2mm		
Thermal Expansion	2.9mm average per 5m @ 50°C change		

Notes:

1. Based on single sided COLORBOND® steel. For other painted steel options please contact your Lysaght representative.
2. To assist minimising the effects of oil canning in LYSAGHT SNAPSEAM™ cladding, it is recommended to keep panel length under 8m. Longer lengths may be available subject to minimum order quantity.

*Please check with your local branch for availability.

MINIMUM ROOF PITCH

The minimum recommended roof pitch for SNAPSEAM™ cyclonic cladding is 3 degree.

INSULATION

Care needs to be taken when installing insulation with SNAPSEAM™ cyclonic roof sheeting. The screw length may need to be increased depending on the thickness and density of the insulation. When the screw is properly tightened into metal there should be a minimum of three (3) threads protruding past the support being fixed in to. For timber the screw must have a min embedment of 25mm into the timber.

For insulation, the use of roof spacing system is recommended to help maintain Rw values as well as minimising any bulging in the profile caused by the insulation. Refer to oil canning section for potential visual impacts of insulation on the product.

Figure 12.1.1:
SNAPSEAM™ profile.

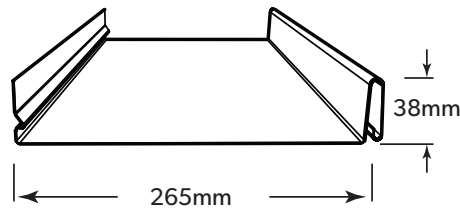

FASTENING SNAPSEAM™ CLADDING TO SUPPORTS

SNAPSEAM™ is concealed fixed to batten supports. This means that clips are screw fastened to the supports and no fastening passes through the sheeting.

Table 12.1.1:

Fastener Specification - Cyclonic

Application	Fixing to steel	Fixing to plywood	Fixing to timber batten
Cyclonic	2 x 10g-16x16 Tri-Fixx Flat head metal screw with minimum class 3 coating with clip At rib edge: 4.8mm Multigrip rivets or equivalent to stitch ribs at 1200mm along sheet and at sheet ends.	3 x 10g-12x25 Flat head type 17 screw with minimum class 3 coating with clip At rib edge: 4.8mm Multigrip rivets or equivalent to stitch ribs at 1200mm along sheet and at sheet ends.	3 x 10g-12x25 Flat head type 17 screw with minimum class 3 coating with clip At rib edge: 4.8mm Multigrip rivets or equivalent to stitch ribs at 1200mm along sheet and at sheet ends.

Figure 12.1.2:
Cyclonic clip to suit SNAPSEAM™

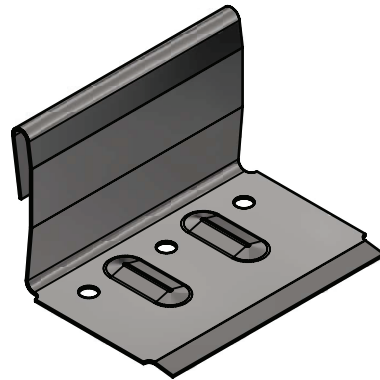

SNAPSEAM™: LIMIT STATE WIND PRESSURE CAPACITIES (KPA)

Cover width	Support Requirement	Design pressure (kPa)	Application
		Strength	
265mm x 0.55mm BMT	Steel batten: 40mm x 0.75mm BMT G550 Batten spacing: 450mm (max) Batten span: 1200mm (max)	5.18	Walling
	* 15mm F11 CD Structural Grade plywood for walling applications Support spacing 600mm (max) Fastener spacing: 450mm	5.18	Walling
	Kingflor 40 0.75mm BMT G550 substrate support Maximum fastener spacing : 250mm (max) Maximum substrate sheet span: 1200mm (max)	5.18	Walling
265mm x 0.75mm BMT	Steel batten: 40mm x 0.75mm BMT G550 Batten spacing: 450mm (max) Batten span: 1200mm (max)	5.18	Roofing & Walling

Notes:

1. Minimum purlin/support thickness must be 1.50mm BMT, G550
2. *15mm F11 structural grade plywood for pressure requirements-walling
3. *19mm F11 Structural grade plywood for Impact requirements-walling

Table 12.1.2

Guide to fastener layout and sheet coverage.

SHEET COVERAGE

265MM

Width of Roof (m)	3	4	5	6	7	8	9	10	11	12	13	14	15	16	17	18	19	20	30	40	50
Number of Sheets	12	16	19	23	27	31	34	38	42	46	50	53	57	61	65	68	72	76	114	151	189

WIDTH COVERED BY 'X' NUMBERS OF SHEETS (M)

265MM

Number of Sheets	3	4	5	6	7	8	9	10	11	12	13	14	15	16	17	18	19	20
Coverage (m)	0.80	1.06	1.33	1.59	1.86	2.12	2.39	2.65	2.92	3.18	3.45	3.71	4.00	4.24	4.51	4.77	5.00	5.30

Screw calculation:

1. 4.4 screws and 2.2 clips per 1m of cladding for 265mm roof /wall cladding @ 450mm fixing centres

END LAPPING

Do not end lap SNAPSEAM™ cladding.

ENDS OF SHEETS

It is usual to allow roof sheets to overhang into gutters by about 50mm.

LAYING PROCEDURE

SNAPSEAM™ is designed to be installed in conjunction with a heavy duty roof sarking as an additional weather-proofing measure.

This sarking / blanket should be installed in accordance with the manufactures recommendations, sealed at the top, free from ripples and puckers, lapped and taped at joins. All laps in the sarking / blanket must be made with 150mm lap, sealed with double sided tape between the faces of the sarking and taped with sisal tape on the outside face.

For maximum weather-tightness, start laying sheets from the end of the building that will be in the lee of the worst-anticipated or prevailing weather. Lay sheets toward prevailing weather.

Also, it is much easier and safer to turn sheets on the ground than up on the roof. Before lifting sheets on to the roof, check that they are the correct way up and the overlapping side is towards the edge of the roof from which installation will start. Place bundles of sheets over or near firm supports, not at mid span of roof member.

1. Position the first sheet to align with the building edge.
2. Screw fix the clips over the under lap edge to battens or ply as shown in Figure 12.2.1 and Figure 12.2.2.
3. Align and engage the next sheet as shown in Figure 12.2.4 and then screw fix as per Step 2.
4. Repeat for the roof/wall run.
5. Flashings and detailing for SNAPSEAM™ are generally the same as for ENSEAM® and as such are not repeated here. Refer to ENSEAM® details 11.2.5 to 11.2.15 for details and architectural directions.

In walling applications, horizontal pressure will need to be applied locally to the sheets to engage the ribs. Use body pressure (torso, hand or foot) or use a rubber mallet if required. Care should be exercised due to the potential instability of the temporary worker access equipment.

To prevent SNAPSEAM™ from sliding downwards in the fixing clips, you should pierce fix through each sheet under the flashing or capping, along the top of the sheets.

12.2 TYPICAL INSTALLATION DETAILS

Figure 12.2.1:

Fixing to steel batten.

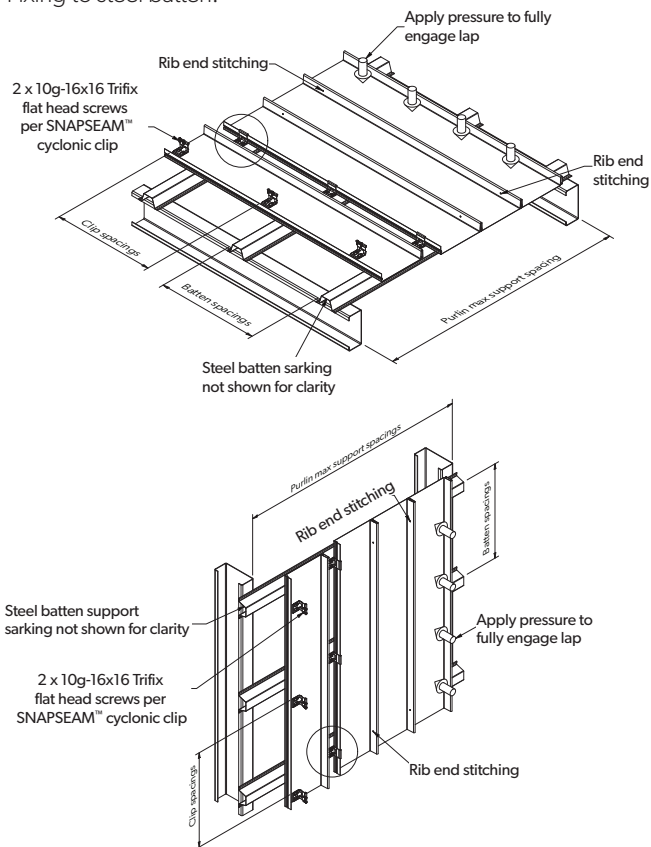

Figure 12.2.2:

Fixing to plywood.

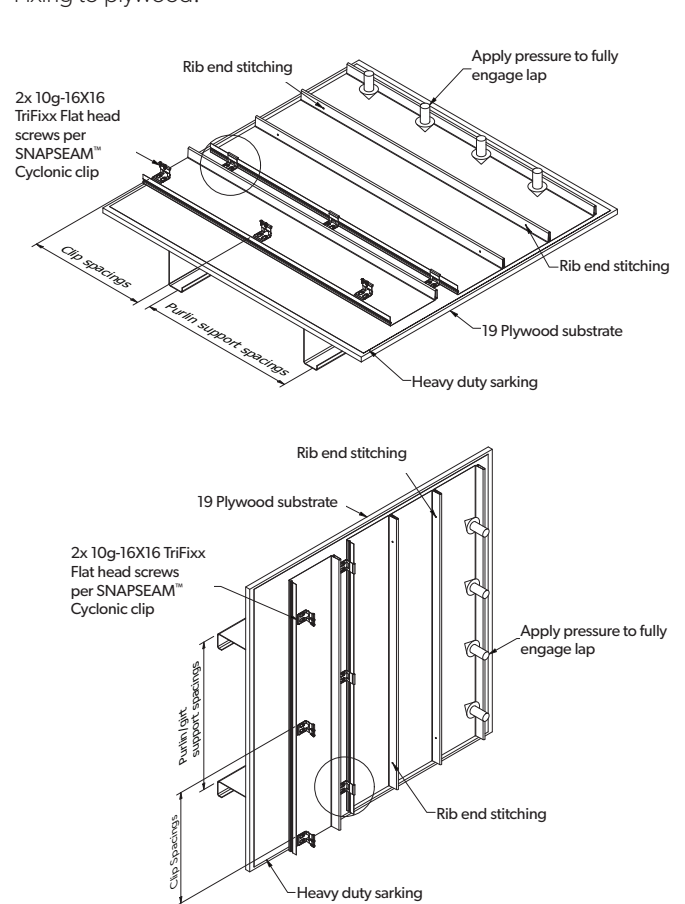

Figure 12.2.3:

Rib end stitching detail.

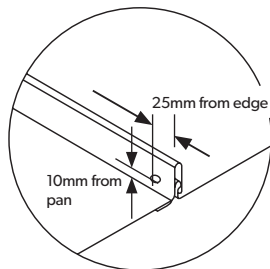

Figure 12.2.4:

Foam Infill detail.

80mm x 40mm closed cell foam infill cut to size and shape on site as required under ridge, hip or corner flashing

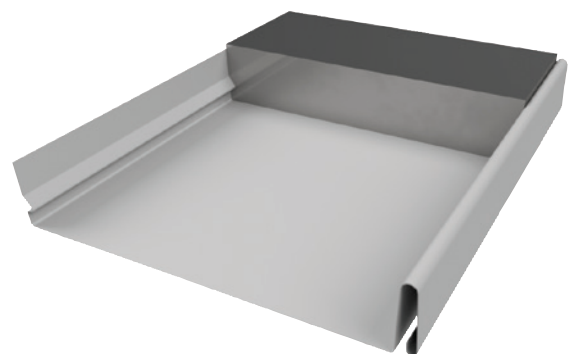

Figure 12.2.5:

SNAPSEAM™ may be fixed to KF40 support for applications where resistance to Wind borne debris is required to AS/NZS 1170.2.

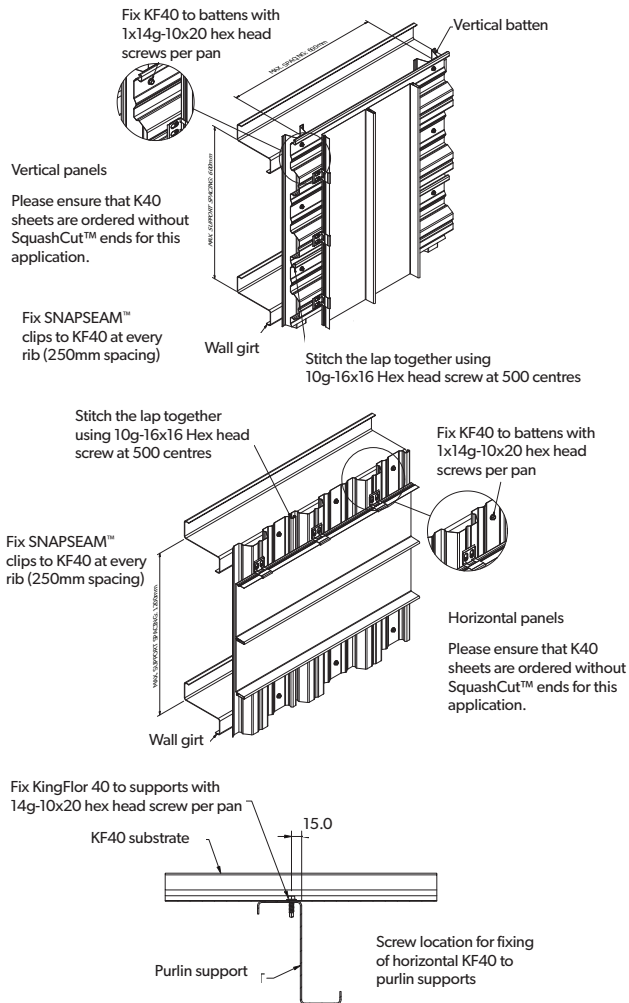

Figure 12.2.6:

Standard lap engagement procedure.

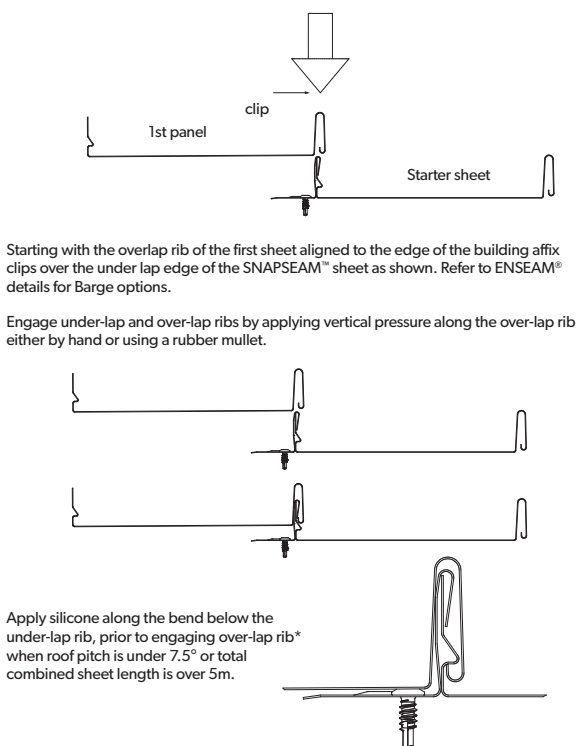
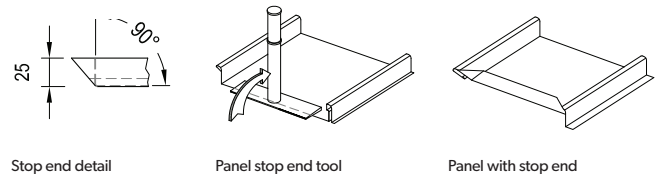

Figure 12.2.7:

Pan turn-up & turn-down details.

TYPICAL STOP END DETAIL

- Stop end procedure:**
1. Place pan into the panel stop end tool, the front edge of the tool must rest between the rib.
 2. While maintaining pressure against the panel, rotate the stop end tool as close to 90° as possible.
 3. Inspect completed bend.



TYPICAL TURN DOWN DETAIL

1. Panels requiring field hemmed ends should be fabricated 25mm longer than the finished panel length. Valley sheets must be field cut to the appropriate angle.
2. Cut back panel joints 25mm.
3. Place protruding pan into the panel hemming tool, the front edge of the tool must rest against the notched joint legs on both sides.
4. While maintaining pressure against the panel joints, rotate the hemming tool as close to 90° as possible.

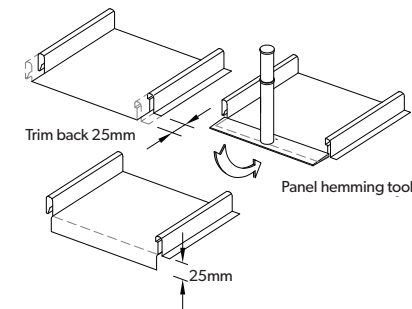
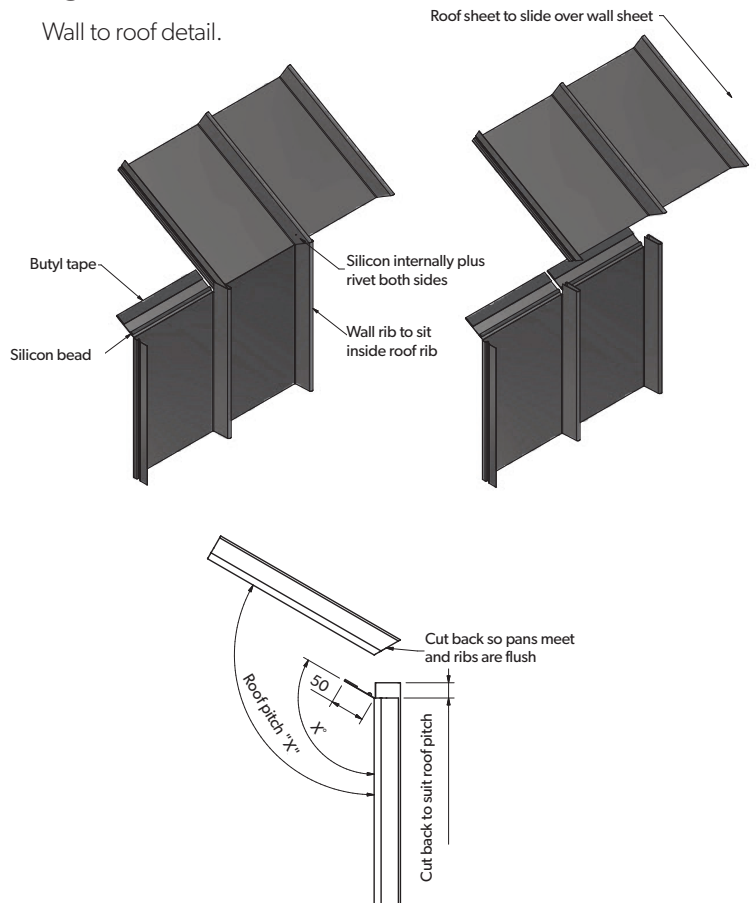

Figure 12.2.8:

Wall to roof detail.



12.3 TYPICAL CONSTRUCTION DETAILS SNAPSEAM™

The construction details presented here represent potential detailing solutions to common construction situations. These details may not be suitable for all projects / situations and users should use professional judgement in determining suitability of the details for their particular project whilst referencing AS 1562.1 and SA HB39. The full suite of ZENITH® constructions details are available for download from <https://bimcontent.com/lysaght/> in both REVIT and PDF format.

12.3.1 SNAPSEAM™ TYPICAL ROOF DETAILS

Figure 12.3.1.1:

Typical Roof Cladding Setout - Unsupported SNAPSEAM™ - Plan View - S04-09

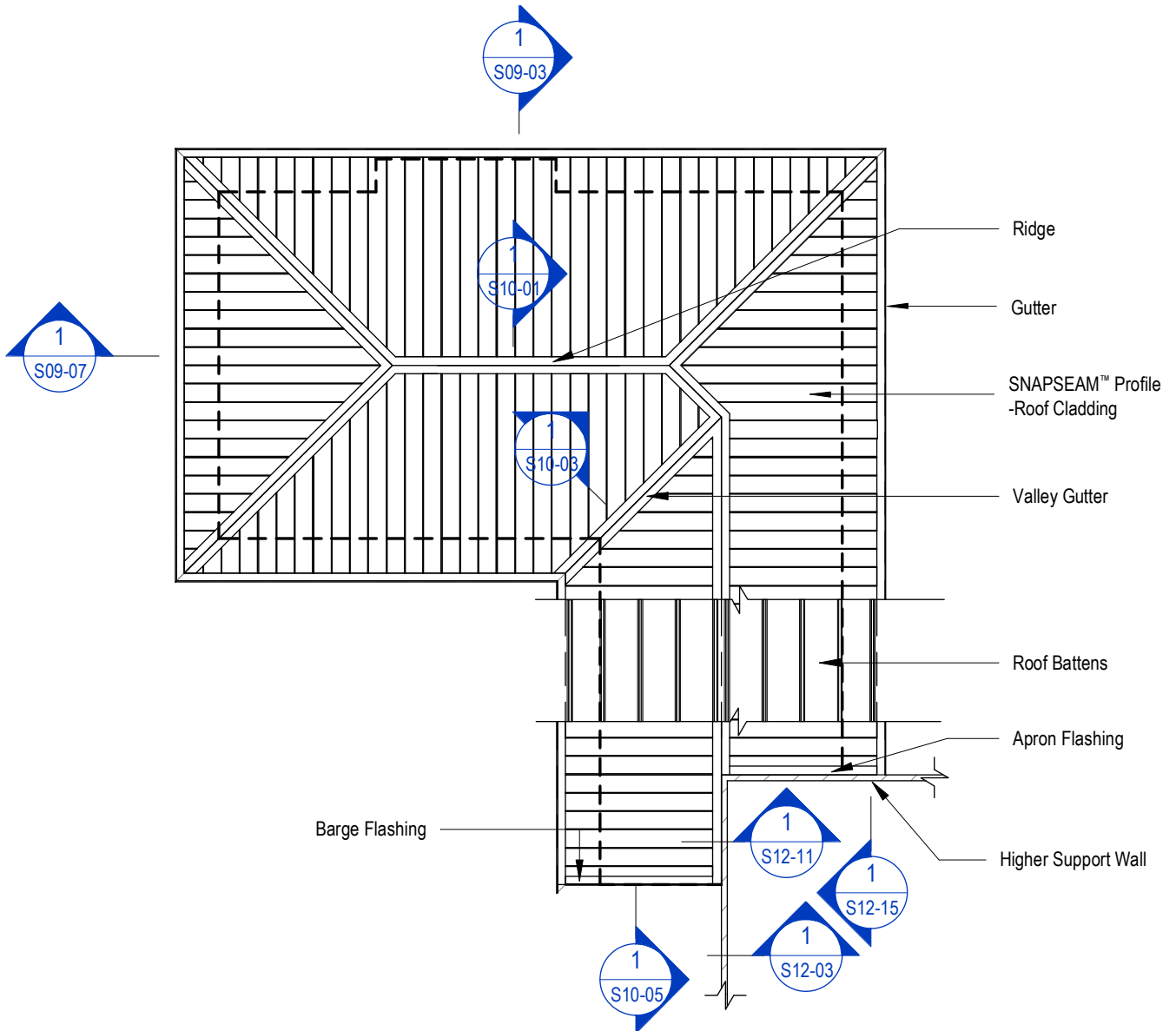

Figure 12.3.1.2:

Top of Wall Eave Detail - Zero Overhang - Unsupported SNAPSEAM™ - Vertical Fix - S09-03

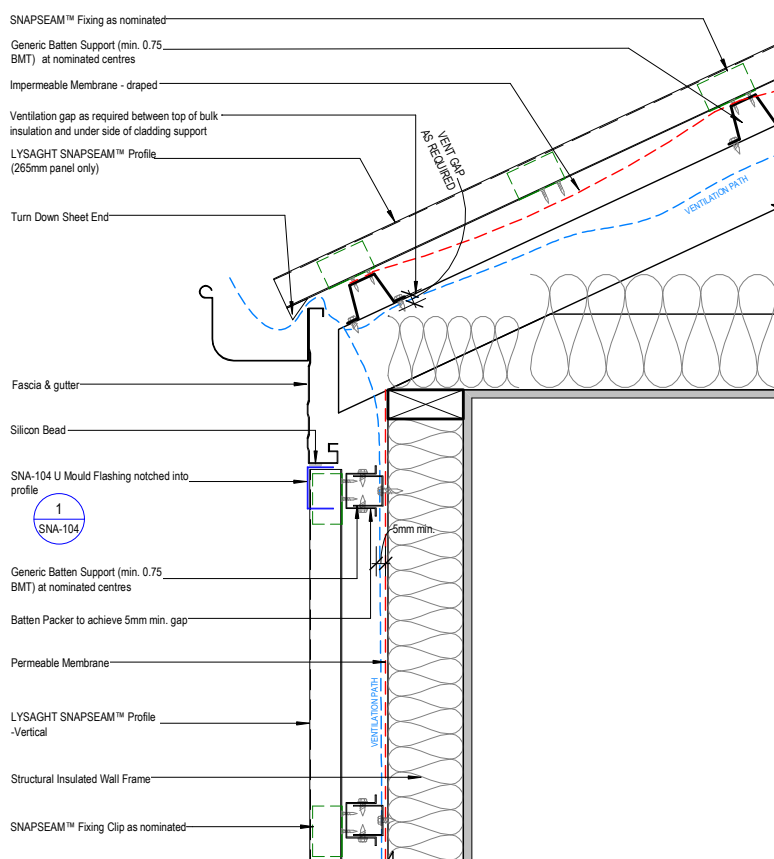

Figure 12.3.1.3:

Top of Wall Eave Detail - Overhang - Unsupported SNAPSEAM™ - Vertical Fix - S09-07

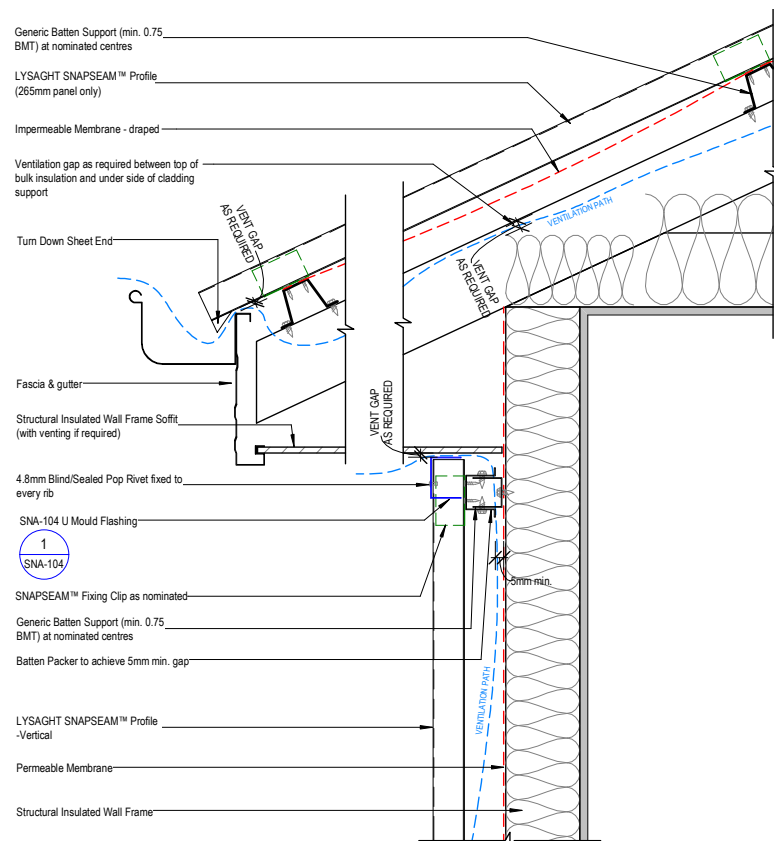

Figure 12.3.1.4:

Ridge Detail - Unsupported SNAPSEAM™ Panel - S10-01

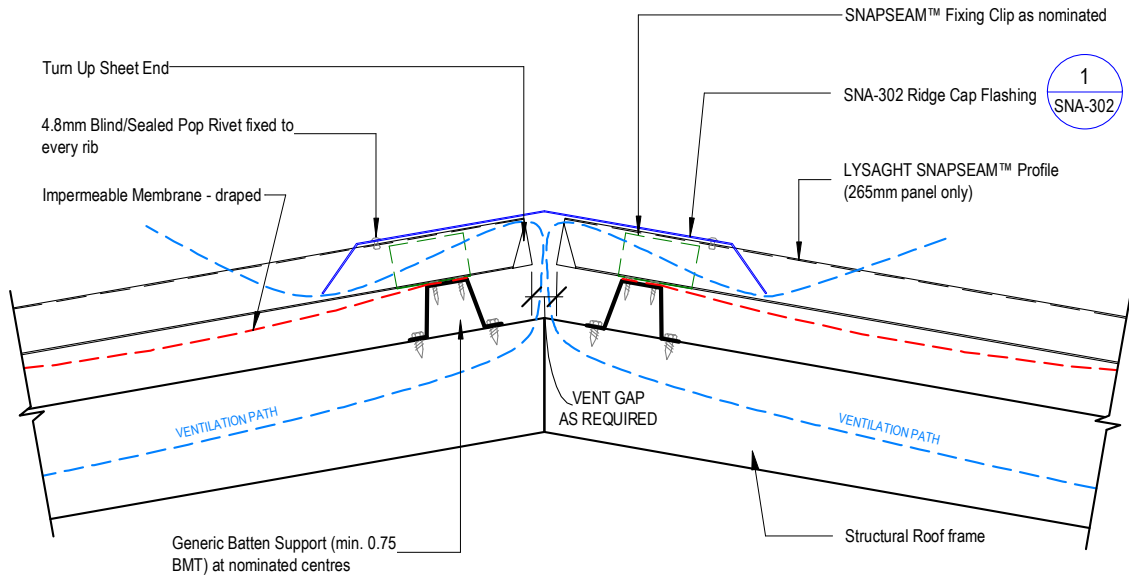

Figure 12.3.1.5:

Valley Detail - Unsupported SNAPSEAM™ Panel - S10-03

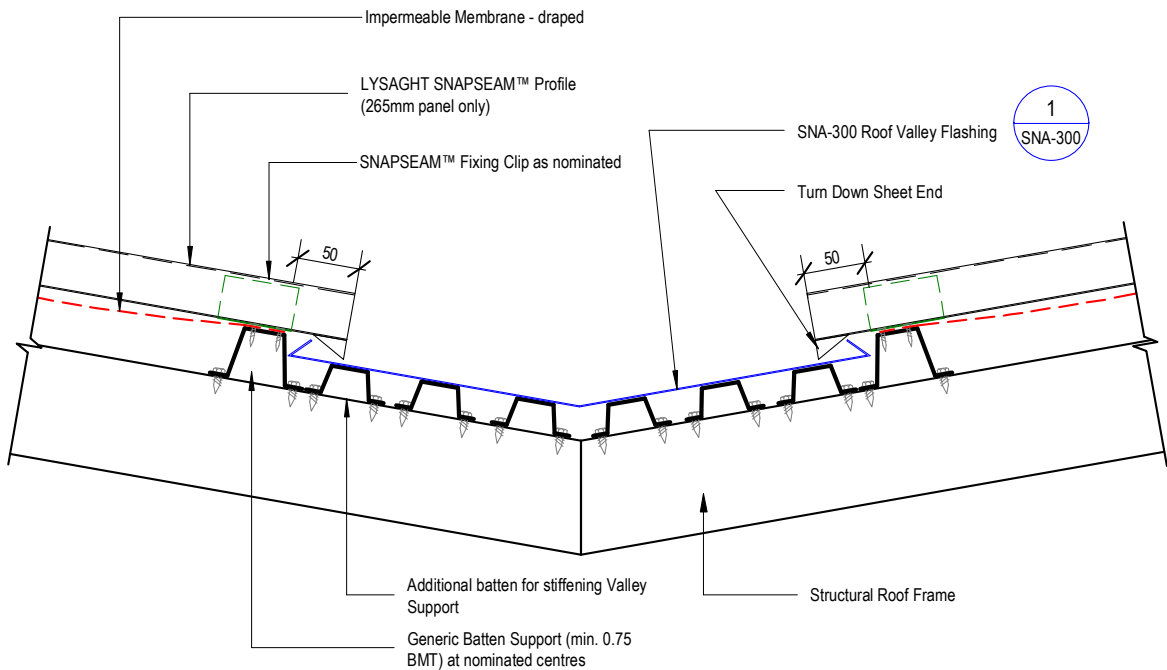

Figure 12.3.1.6:

Gable Detail - Unsupported SNAPSEAM™ Roof to Wall - Vertical Fix - S10-05

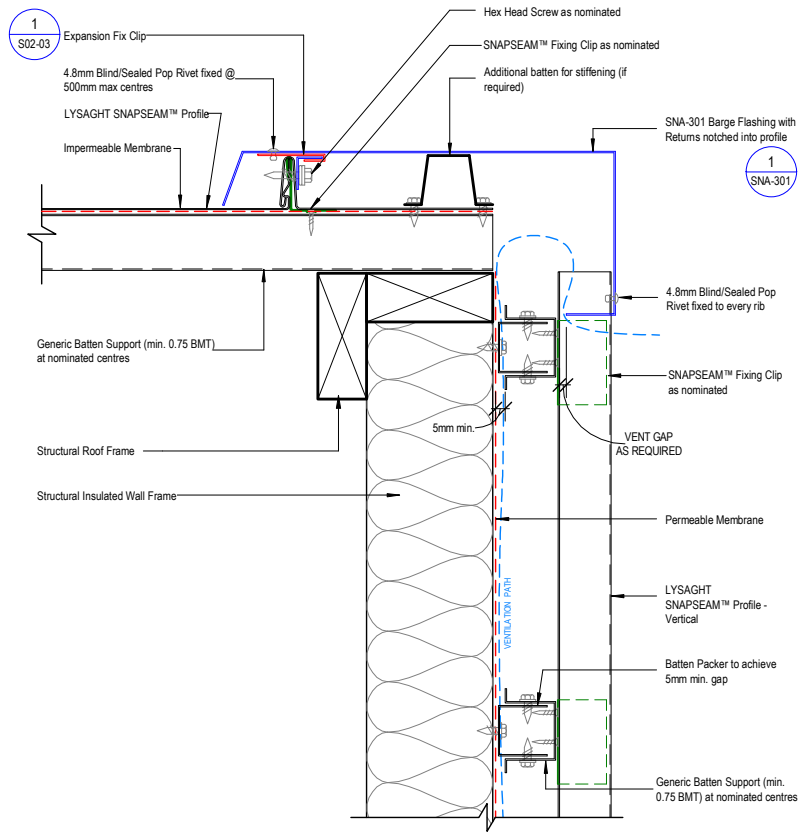

Figure 12.3.1.7:

Parapet Wall Detail - Unsupported SNAPSEAM™ Panel - Vertical Fix - S12-03

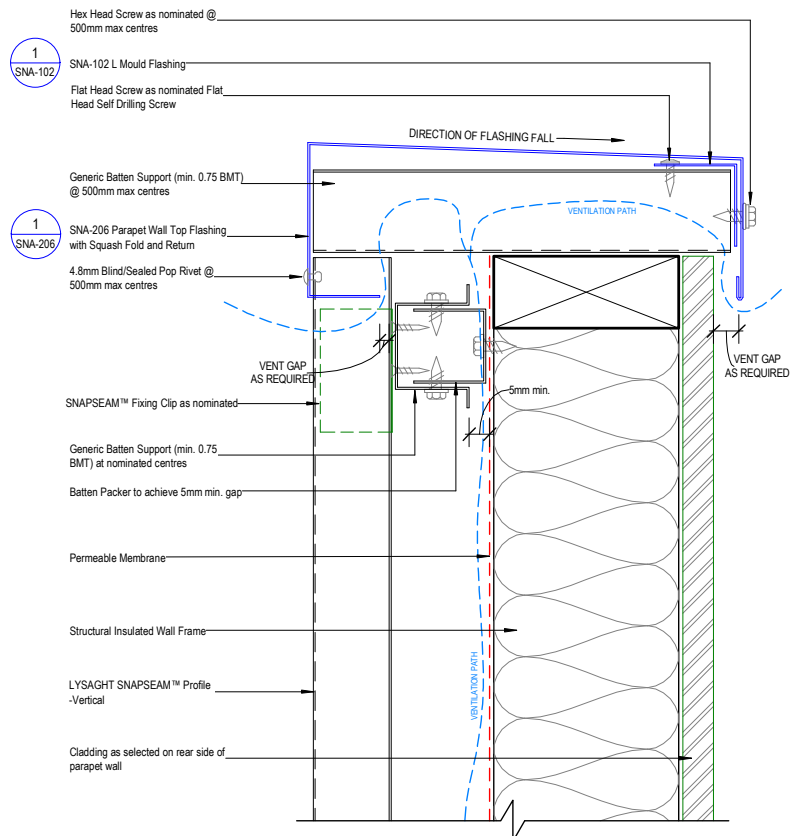

Figure 12.3.1.8:

SNAPSEAM™ Vertical Fix Wall to SNAPSEAM™ Roof - Unsupported - Side View - S12-11

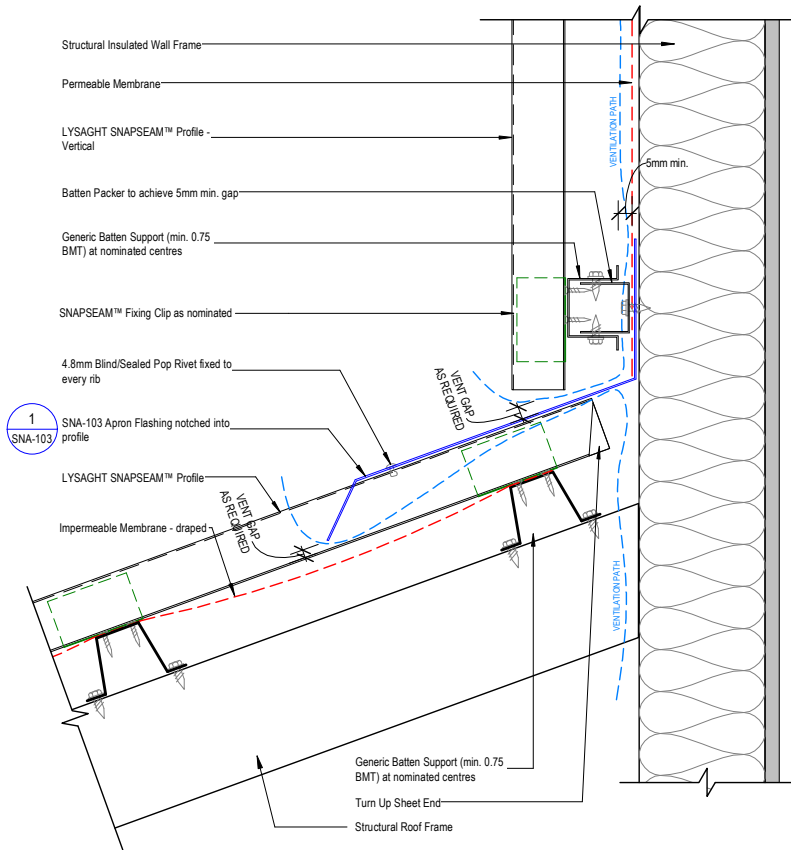
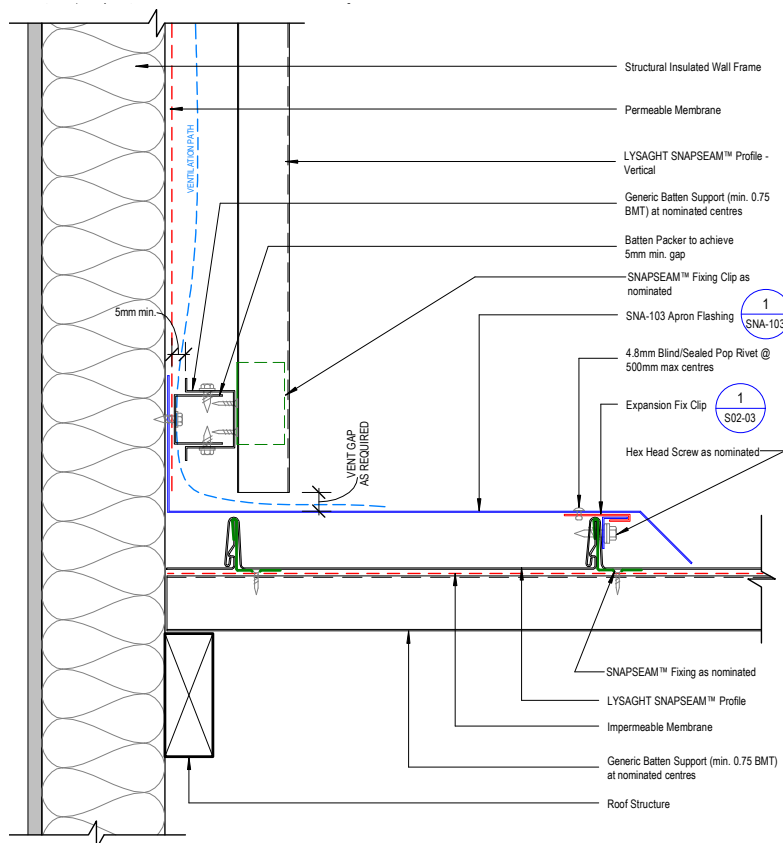

Figure 12.3.1.9:

SNAPSEAM™ Vertical Fix Wall to SNAPSEAM™ Roof - Unsupported - End View - S12-15



12.3.2 SNAPSEAM™ TYPICAL WALL DETAILS - HORIZONTAL FIX

Figure 12.3.2.1:

Typical Wall Cladding Setout - Unsupported SNAPSEAM™ Panel Horizontal Fix - Plan View - S04-01

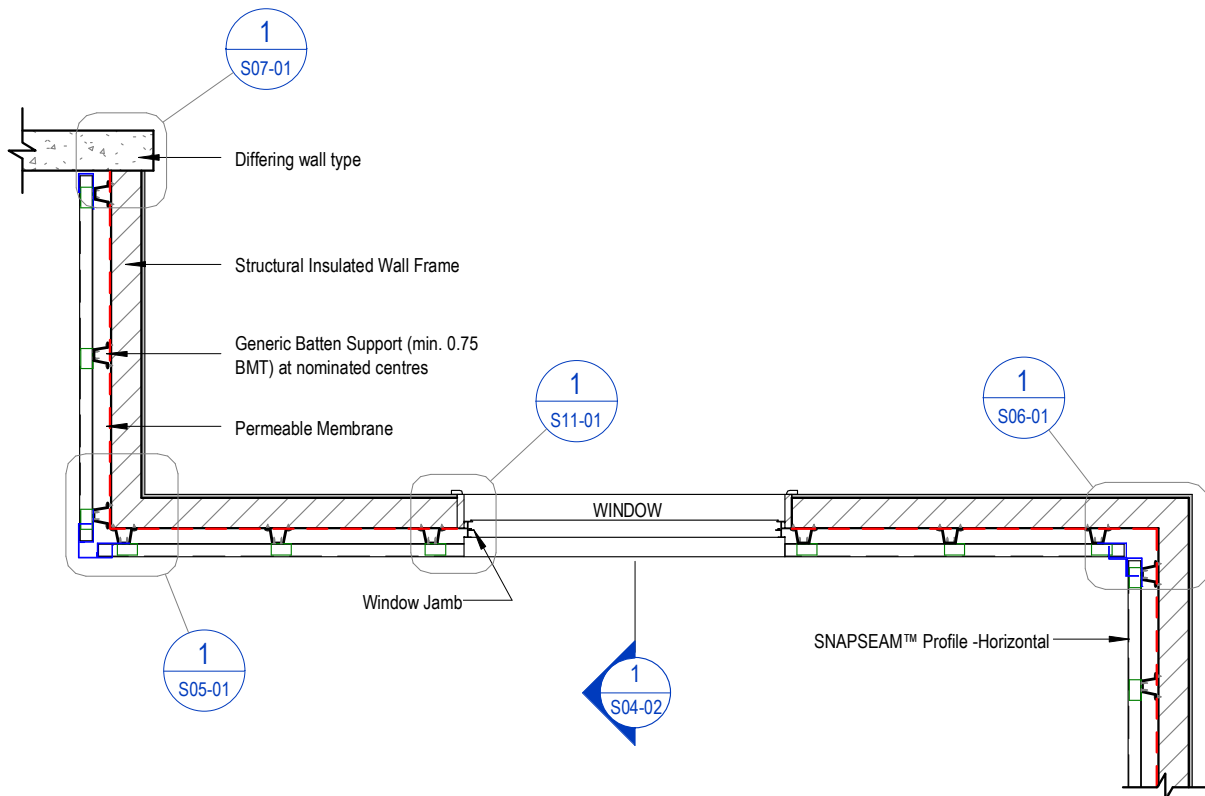

Figure 12.3.2.2:

Typical Wall Cladding Setout - Unsupported SNAPSEAM™ - Horizontal Fix - Sectional View - S04-02

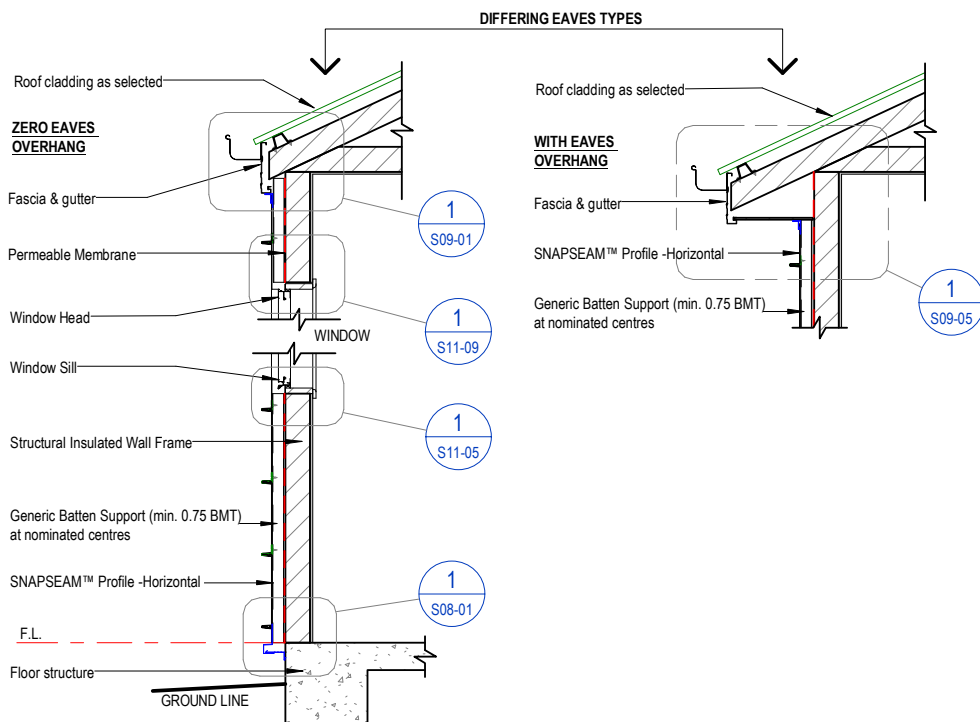

Figure 12.3.2.3:

External Corner Detail - Unsupported SNAPSEAM™ Panel - Horizontal Fix - S05-01

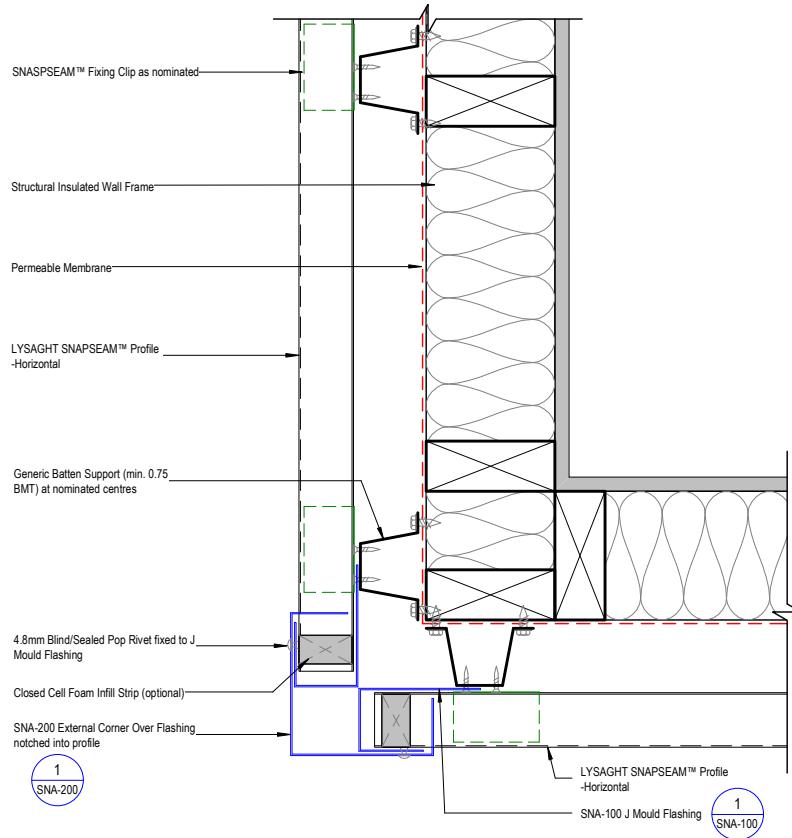

Figure 12.3.2.4:

Internal Corner Detail - Unsupported SNAPSEAM™ Panel - Horizontal Fix - S06-01

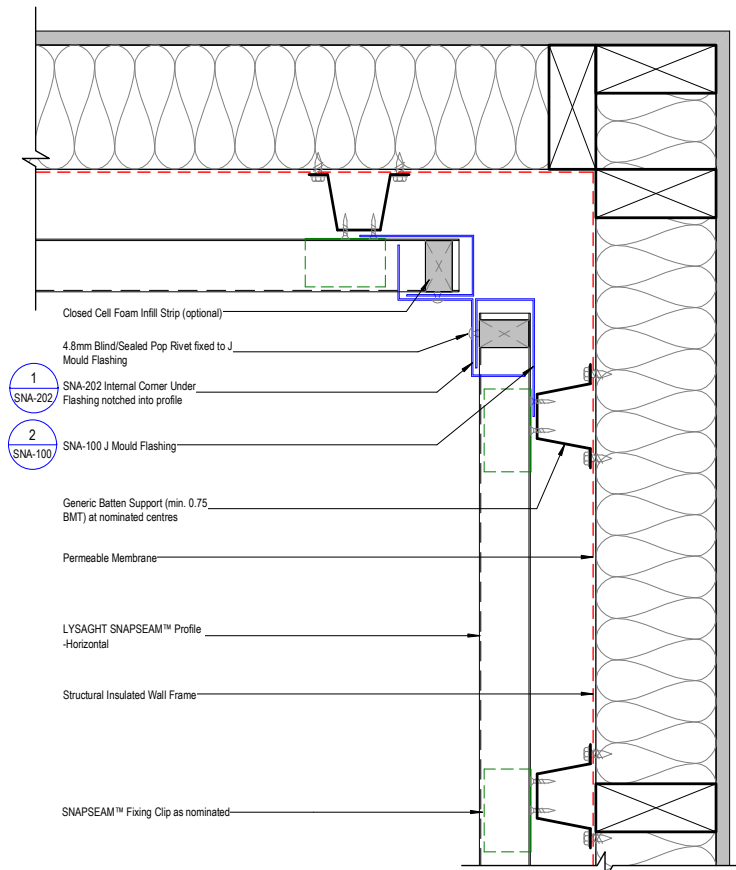

Figure 12.3.2.5:

Wall Closure Detail - Unsupported SNAPSEAM™ Panel - Horizontal Fix - S07-01

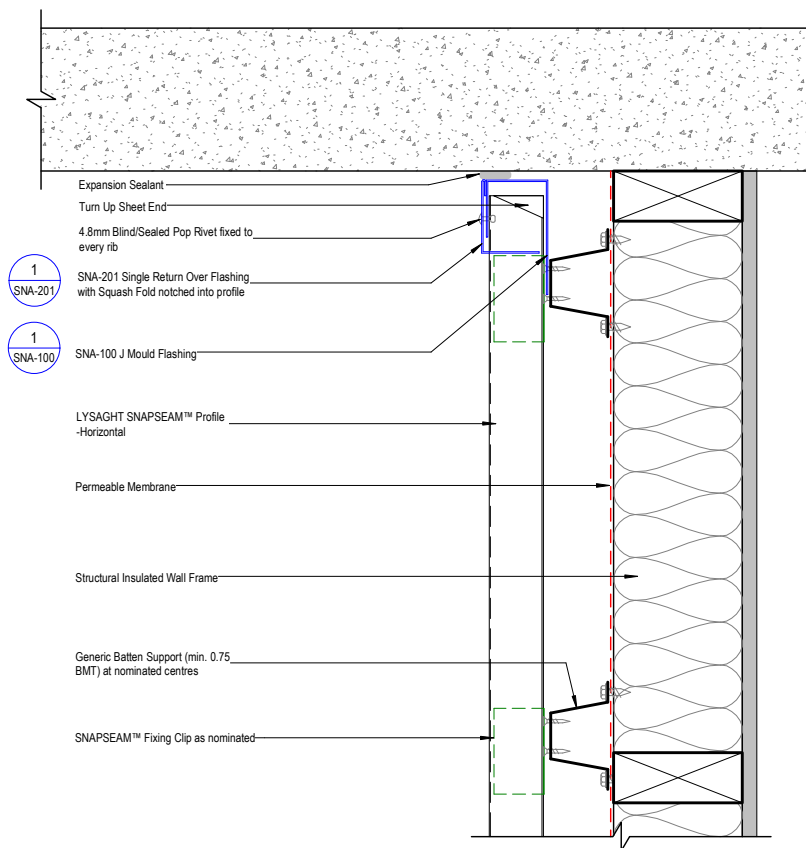

Figure 12.3.2.6:

Window Jamb Detail - Unsupported SNAPSEAM™ Panel - Horizontal Fix - S11-01

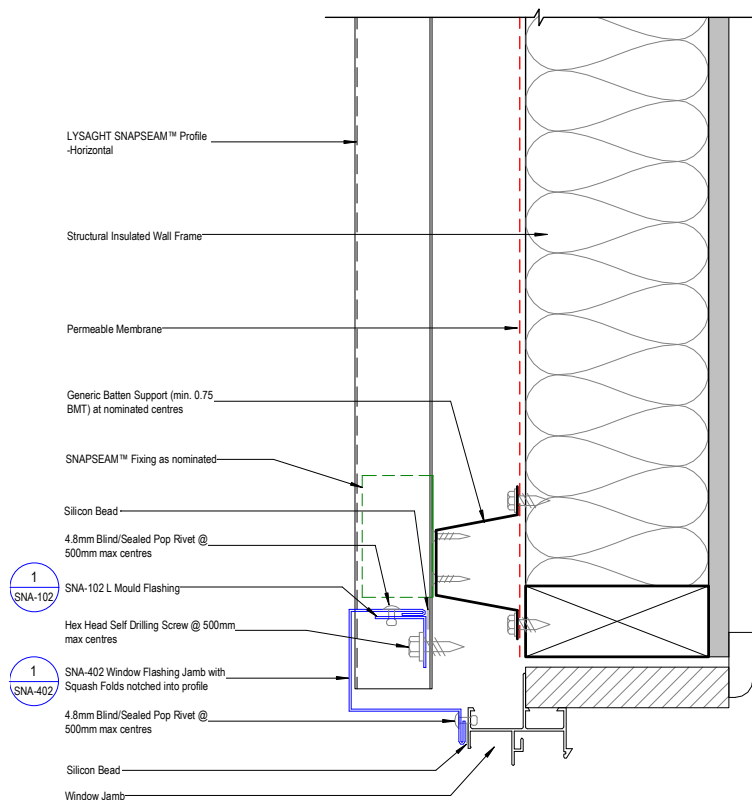

Figure 12.3.2.7:

Wall Base Detail - Unsupported SNAPSEAM™ Panel - Horizontal Fix - S08-01

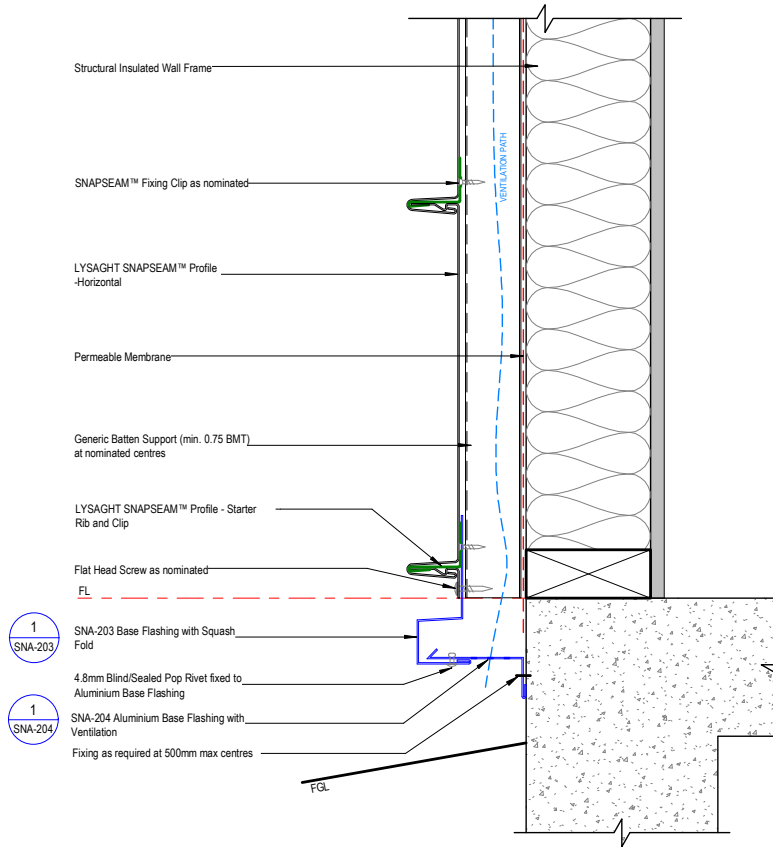

Figure 12.3.2.8:

Top of Wall Eave Detail - Zero Overhang - Unsupported SNAPSEAM™ - Horizontal Fix - S09-01

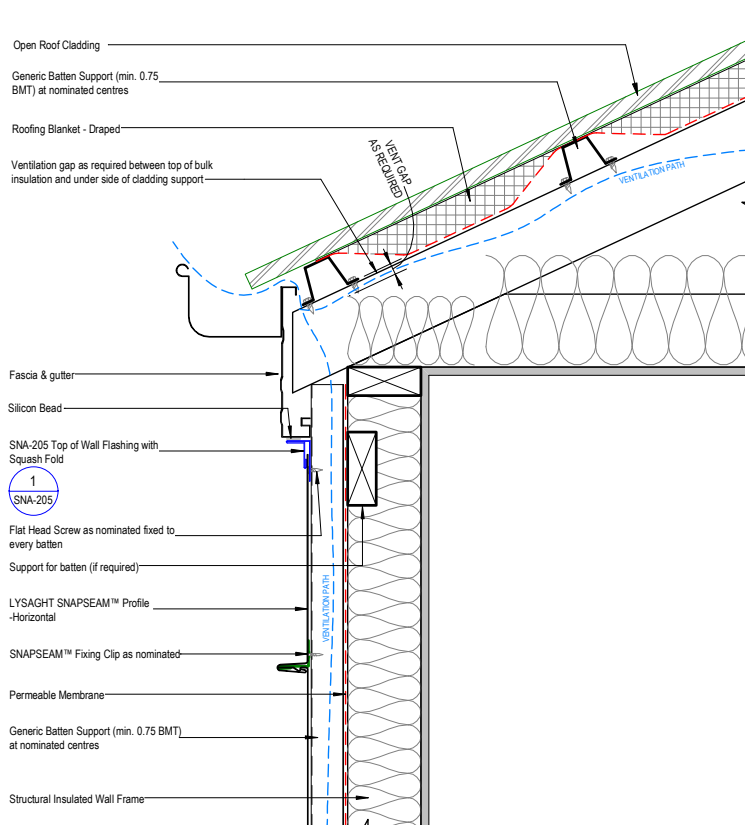

Figure 12.3.2.9:

Top of Wall Eave Detail - Overhang - Unsupported SNAPSEAM™ - Horizontal Fix - S09-05

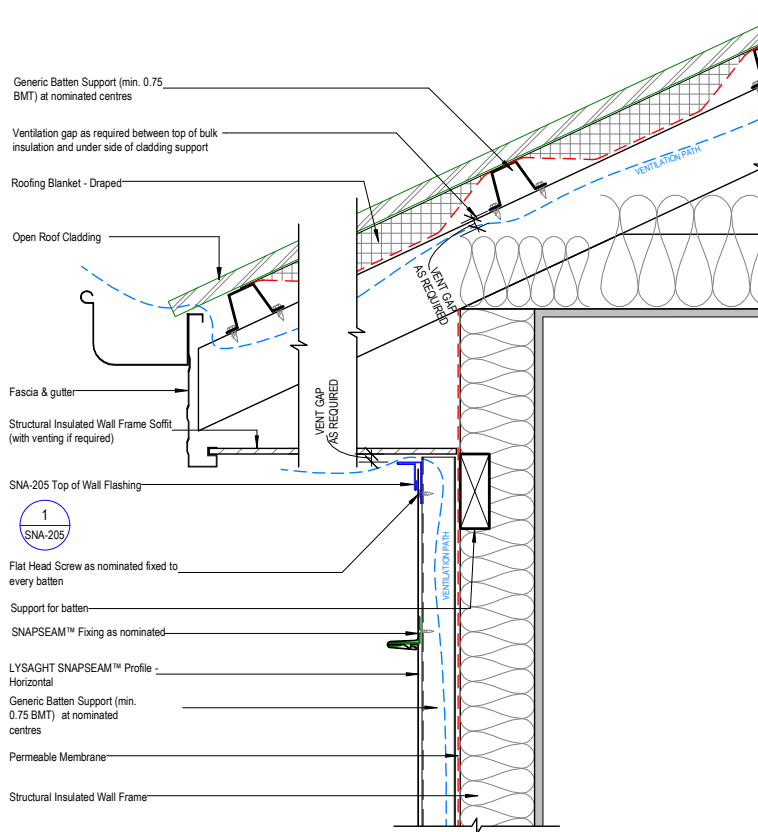

Figure 12.3.2.10:

Window Sill Detail - Unsupported SNAPSEAM™ Panel - Horizontal Fix - S11-05

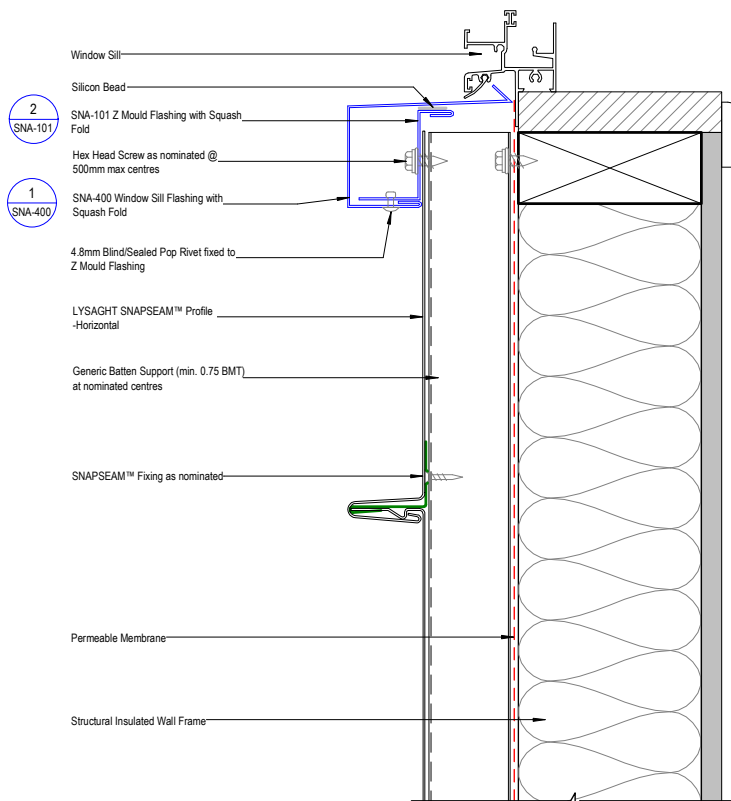
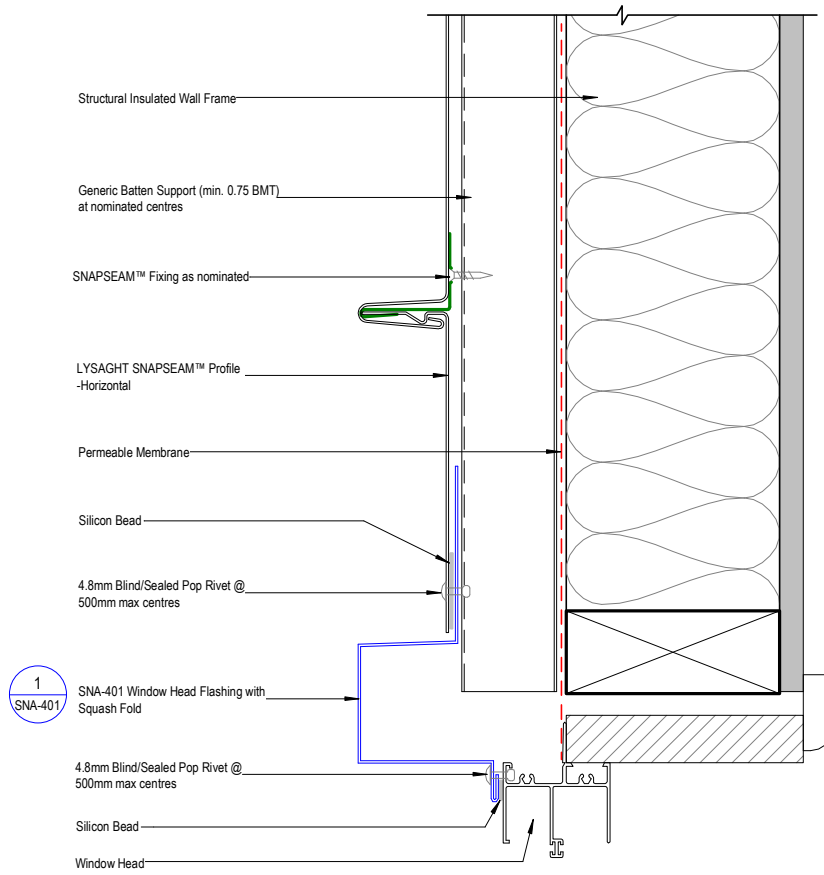

Figure 12.3.2.11:

Window Head Detail - Unsupported SNAPSEAM™ Panel - Horizontal Fix - S11-09



12.3.3 SNAPSEAM™ TYPICAL WALL DETAILS - VERTICAL FIX

Figure 12.3.3.1:

Typical Wall Cladding Setout - Unsupported SNAPSEAM™ Vertical Fix - Plan View - S04-05

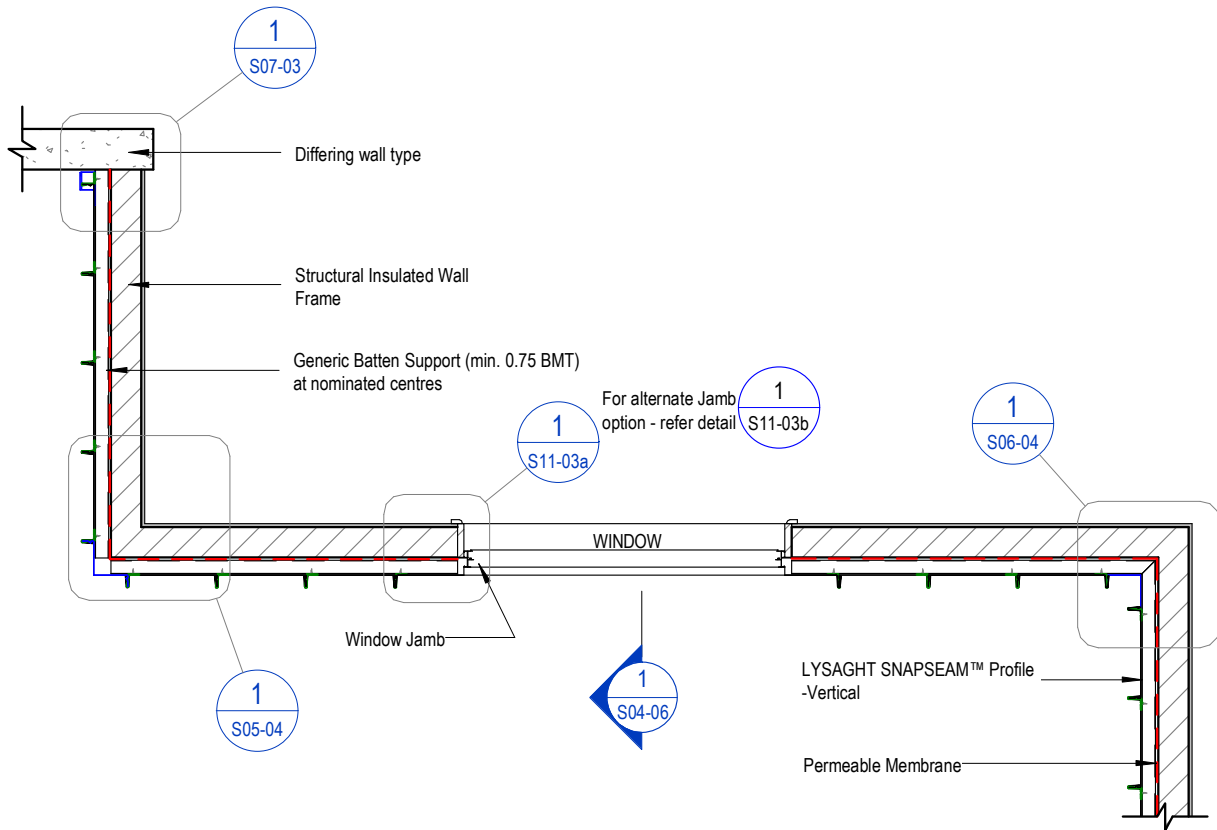

Figure 12.3.3.2:

Typical Wall Cladding Setout - Unsupported SNAPSEAM™ - Vertical Fix - Sectional View - S04-06

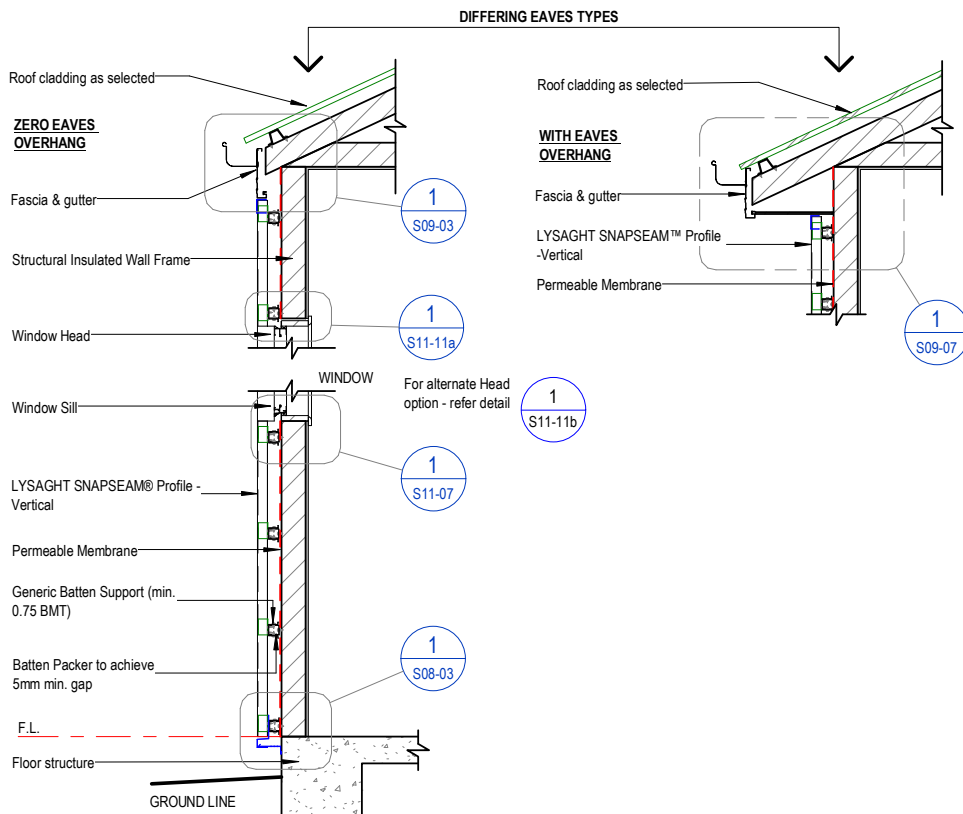

Figure 12.3.3.3:

External Corner Detail - Unsupported SNAPSEAM™ Panel - Vertical Underlap Underlap - S05-04

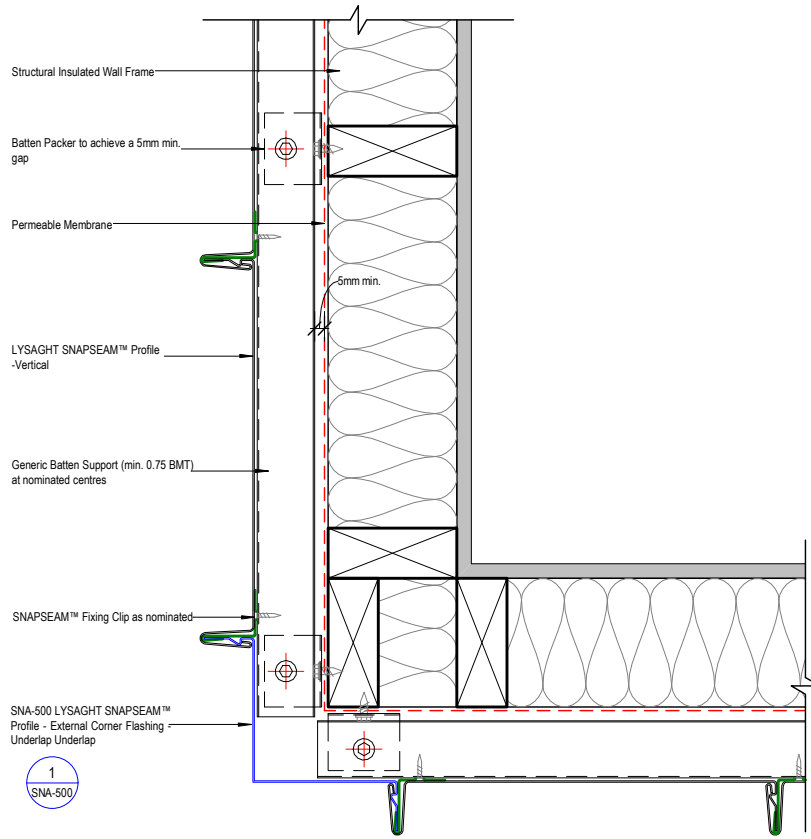

Figure 12.3.3.4:

Internal Corner Detail - Unsupported SNAPSEAM™ Panel - Vertical Underlap Underlap - S06-04

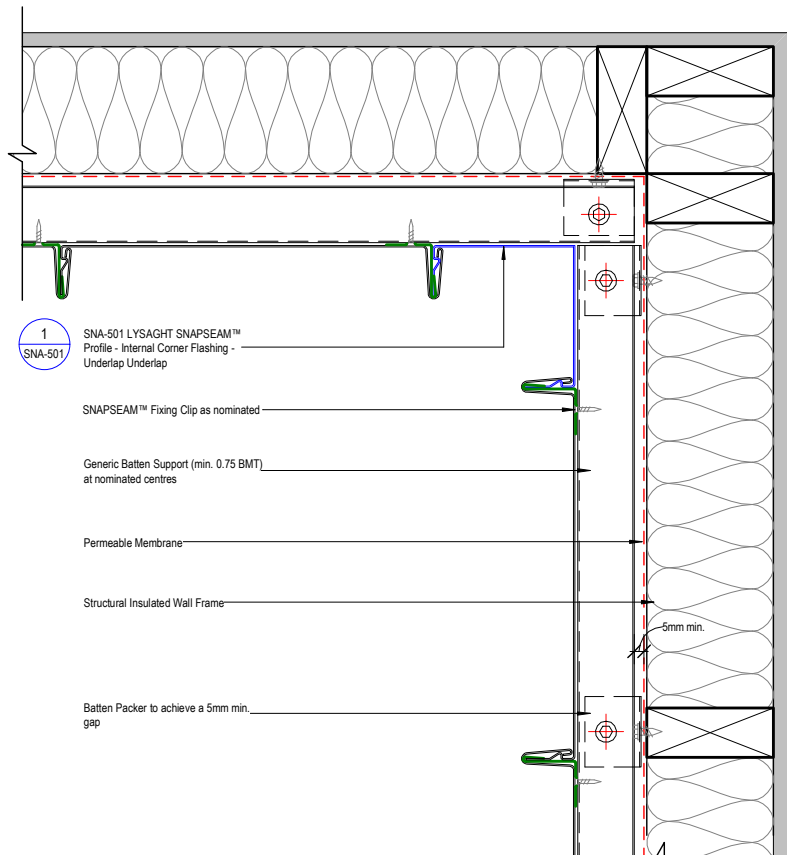

Figure 12.3.3.5:

Wall Closure Detail - Unsupported SNAPSEAM™ Panel - Vertical Fix - S07-03

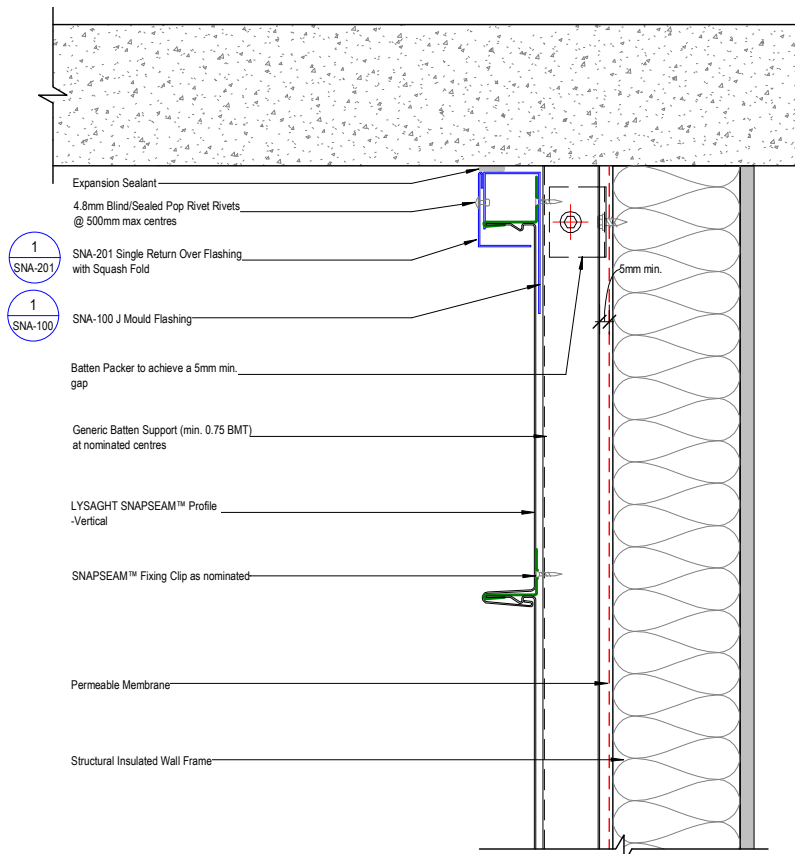

Figure 12.3.3.6:

Window Jamb Detail - Unsupported SNAPSEAM™ Panel - Vertical Fix Option 1 - S11-03a

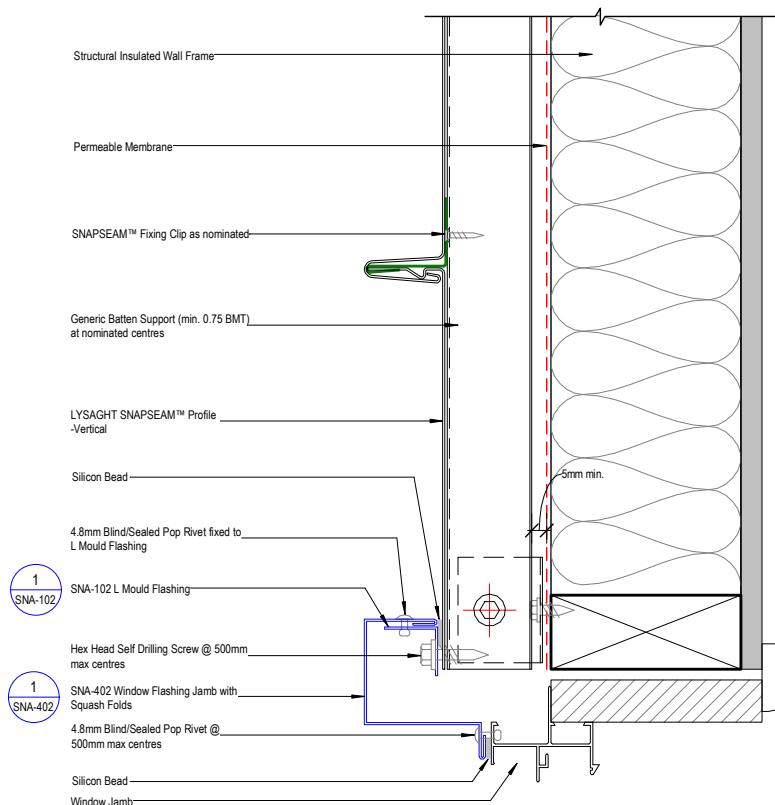

Figure 12.3.3.7:

Window Jamb Detail - Unsupported SNAPSEAM™ Panel - Vertical Fix Option 2 - S11-03b

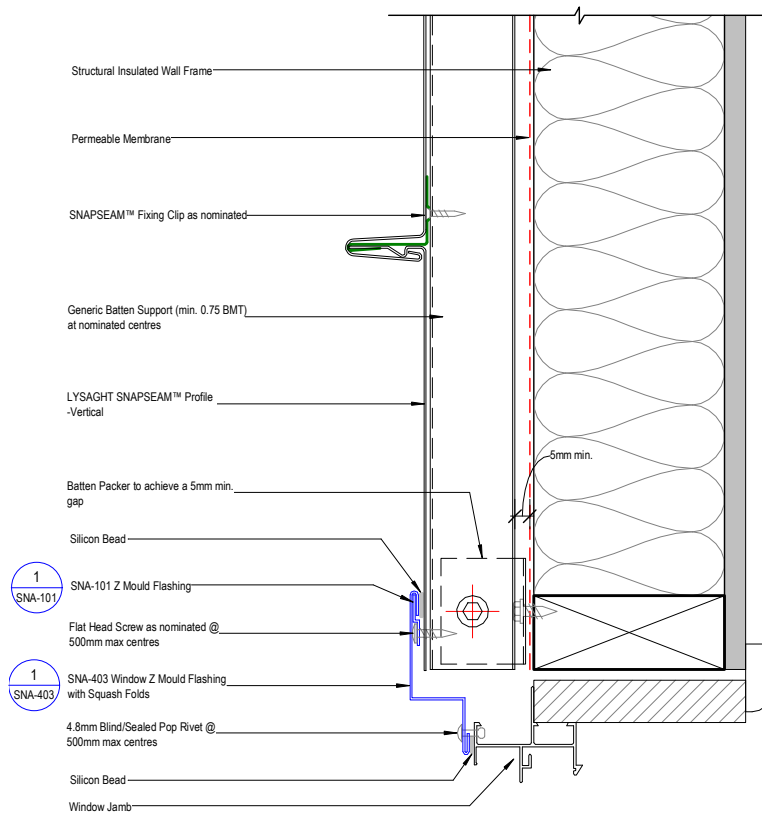

Figure 12.3.3.8:

Wall Base Detail - Unsupported SNAPSEAM™ Panel - Vertical Fix - S08-03

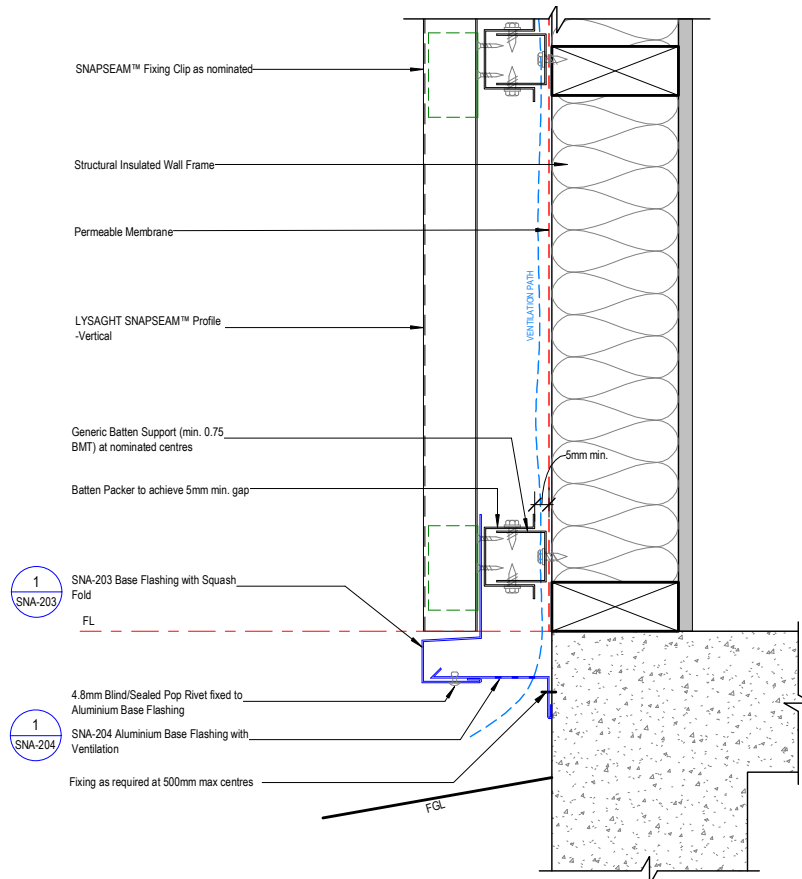

Figure 12.3.3.9:

Top of Wall Eave Detail - Zero Overhang - Unsupported SNAPSEAM™ - Vertical Fix - S09-03

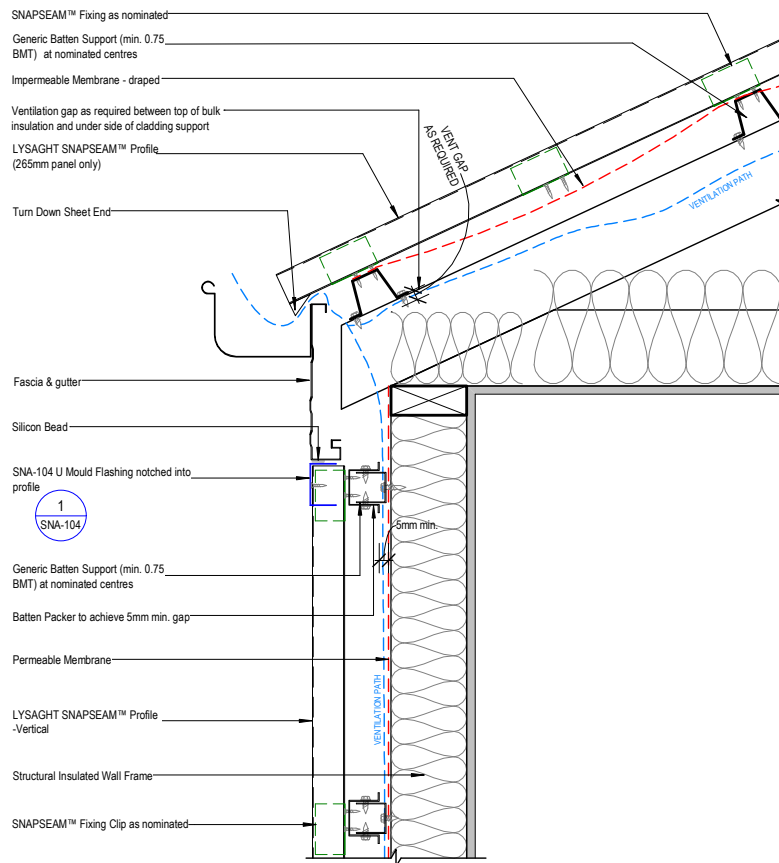

Figure 12.3.3.10:

Top of Wall Eave Detail - Overhang - Unsupported SNAPSEAM™ - Vertical Fix - S09-07

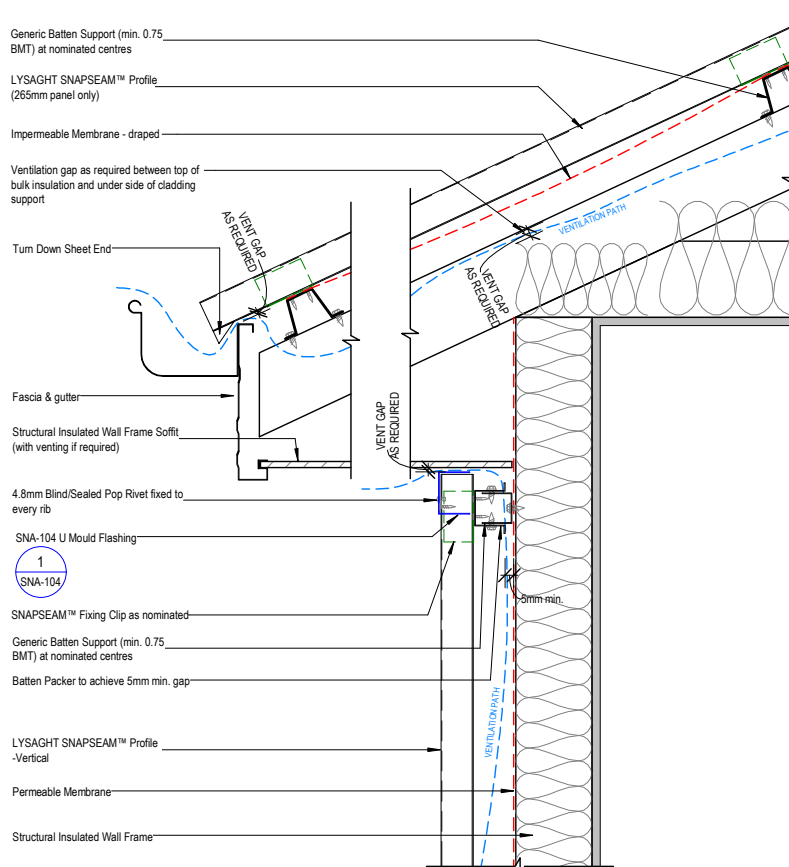

Figure 12.3.3.11:

Window Sill Detail - Unsupported SNAPSEAM™ Panel - Vertical Fix - S11-07

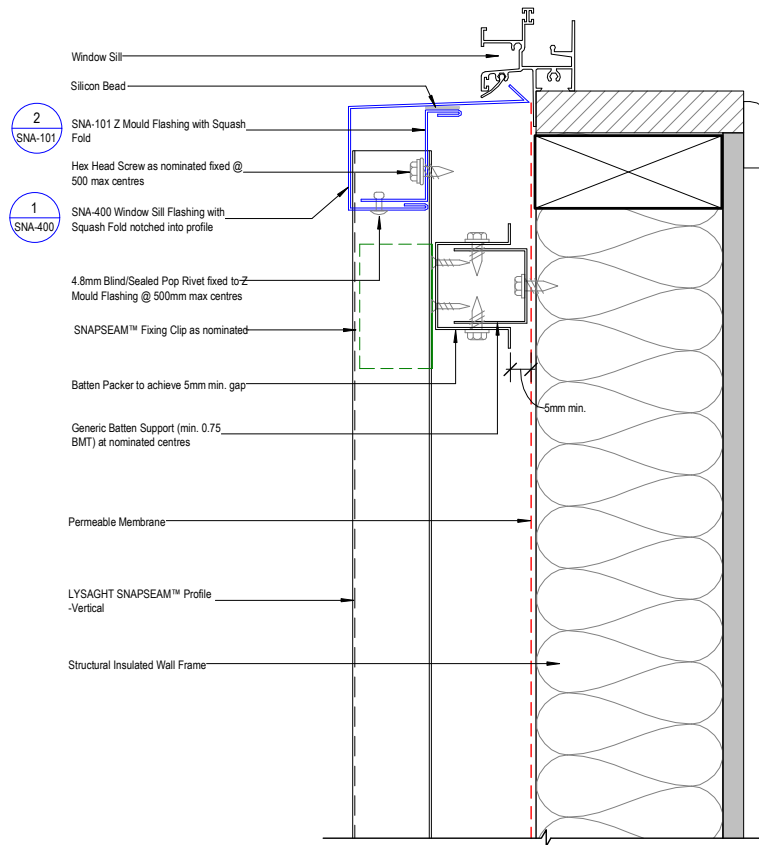

Figure 12.3.3.12:

Window Head Detail - Unsupported SNAPSEAM™ Panel - Vertical Fix Option 1 - S11-11a

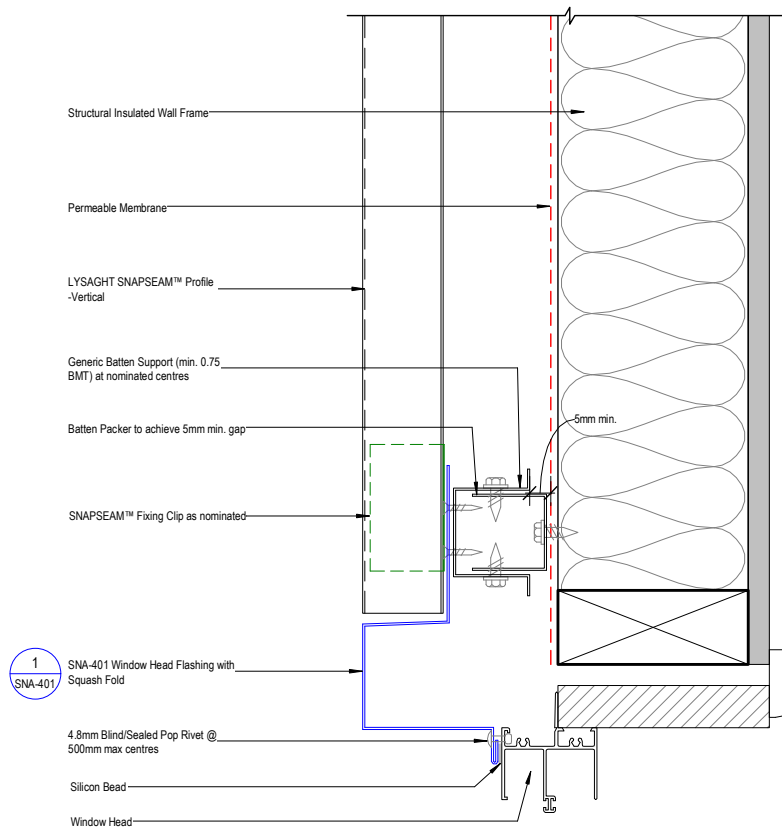
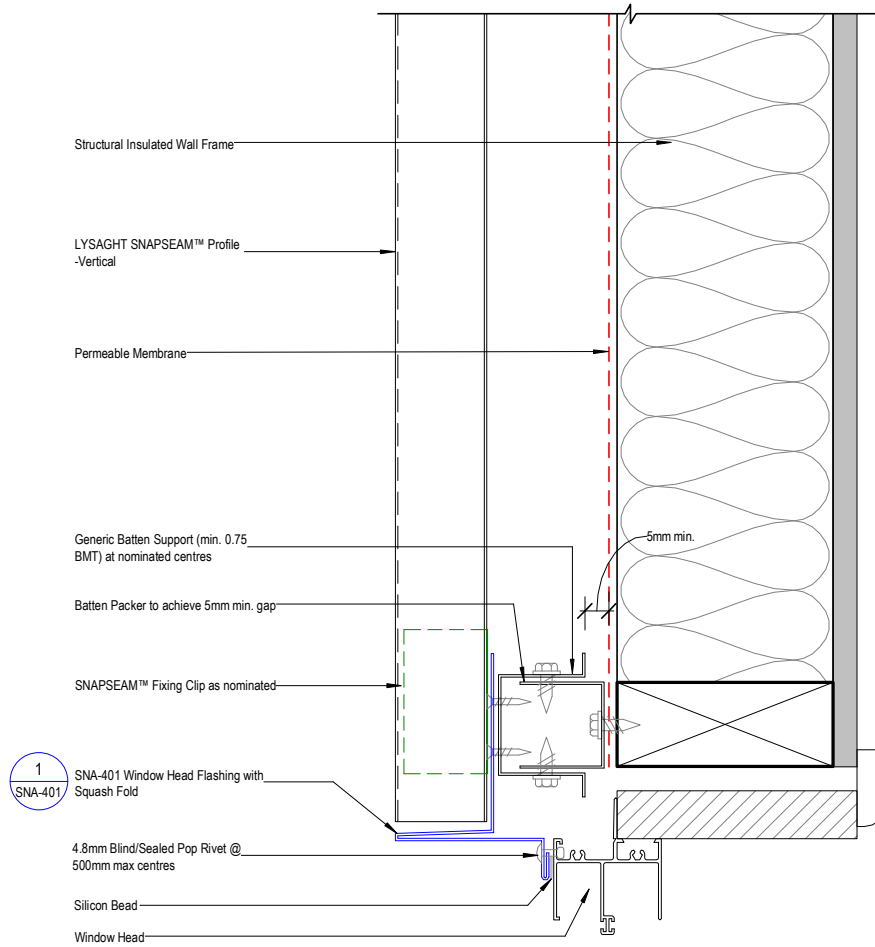

Figure 12.3.3.13:

Window Head Detail - Unsupported SNAPSEAM™ Panel - Vertical Fix Option 2 - S11-11b



12.3.4 SNAPSEAM™ MANSARD ROOF / WALL

Figure 12.3.4.1:

SNAPSEAM™ Mansard Roof - S12-21

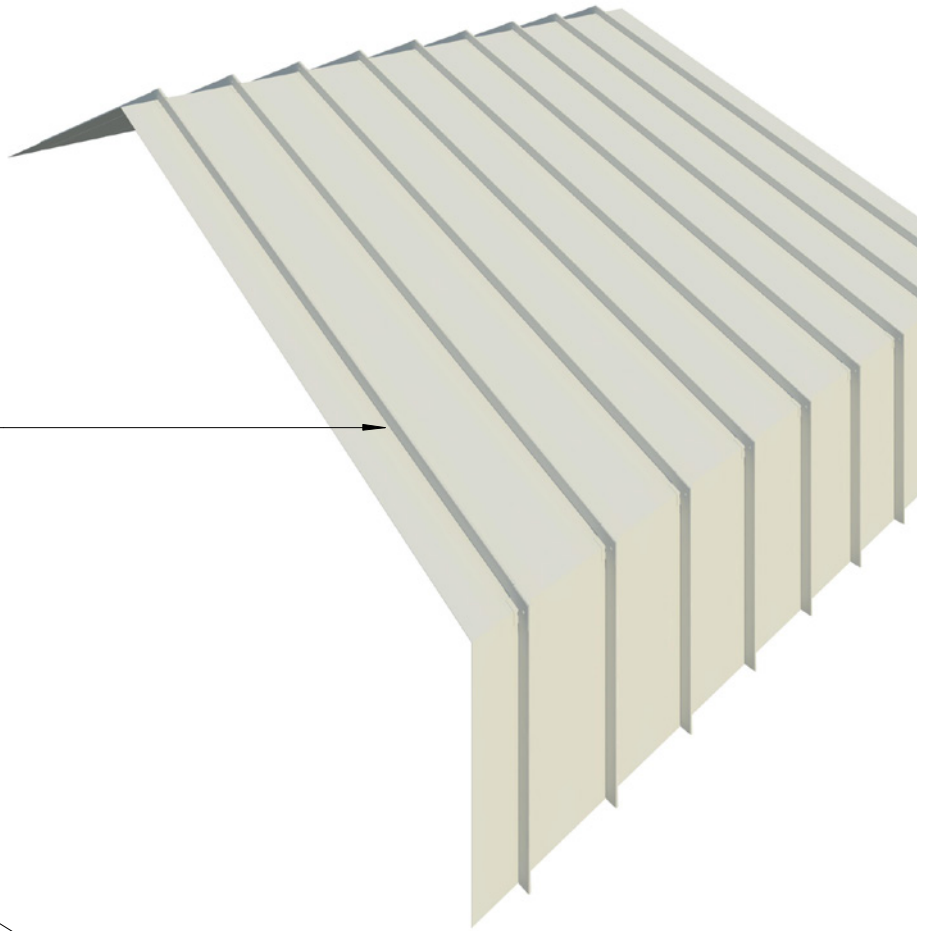

Continuous sheeting. Mansard roof with trays bent and the cut ribs waterproofed with sealed rib caps.

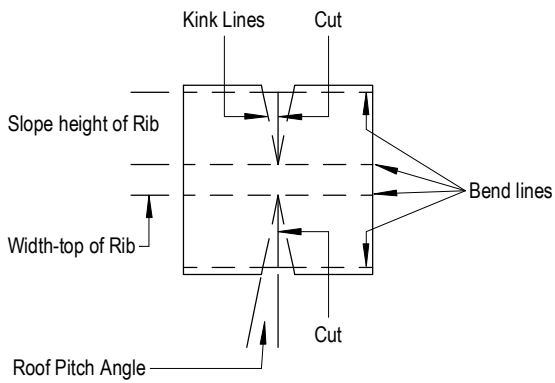

Development Cap

A S12-21 - Development of Cap
1 : 1



Apply recommended sealant inside ends and along bottom of cap. Place in position over opened rib and fasten with four 4mm blind rivets.

Figure 12.3.4.2:

Typical Wall Cladding Setout - Unsupported SNAPSEAM™ Vertical Fix - Plan View - S12-22

STEP 1

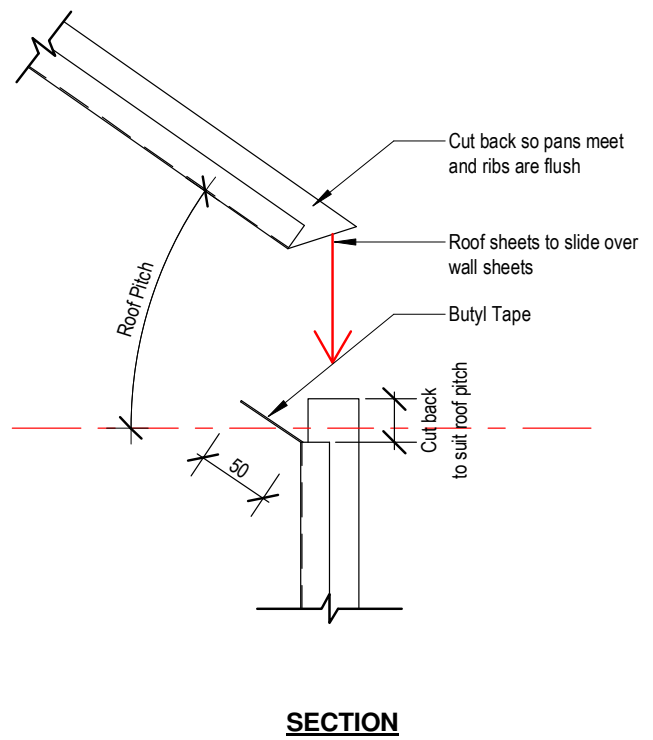
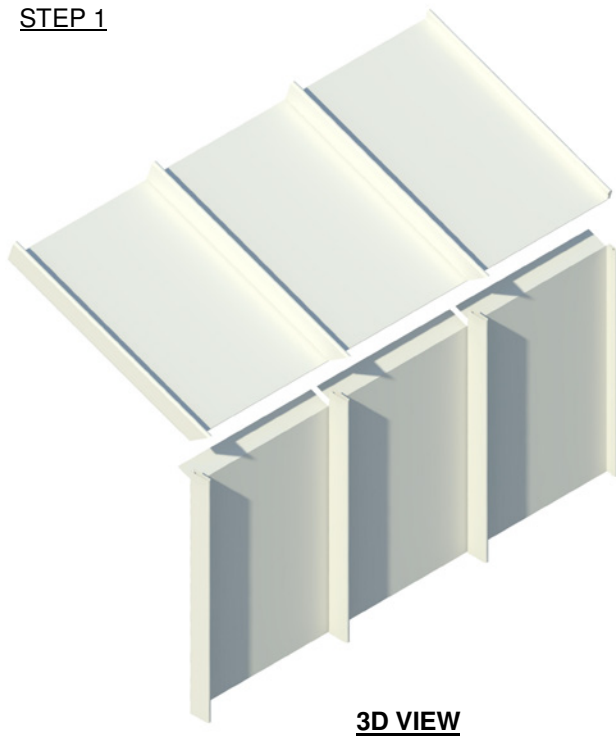

STEP 2

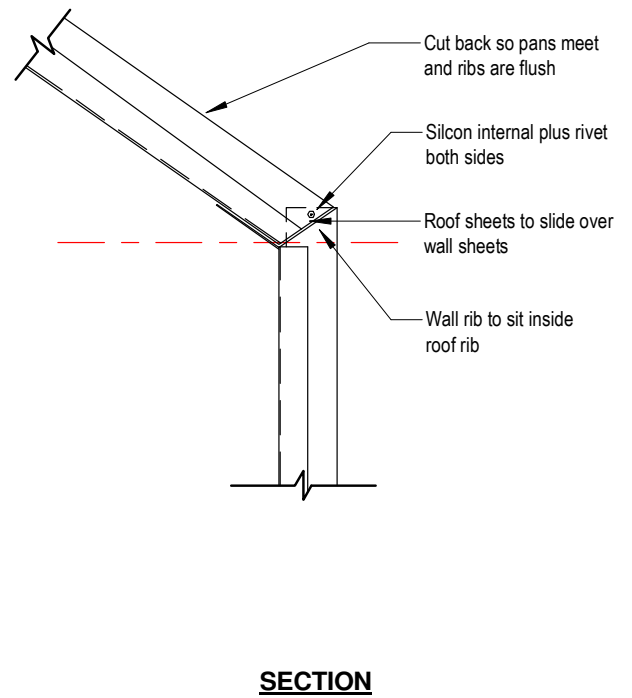
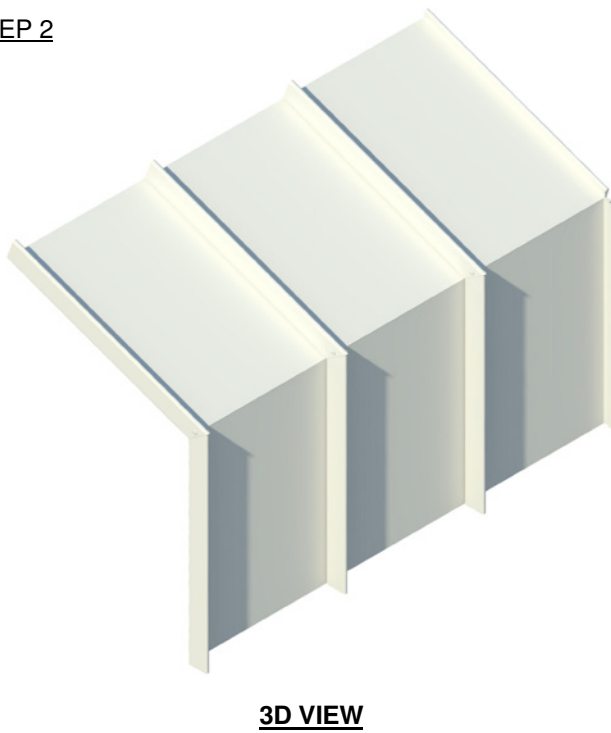

12.3.5 SNAPSEAM™ TYPICAL FLASHINGS

Figure 12.3.5.1:

SNA-100 - J Mould Flashings

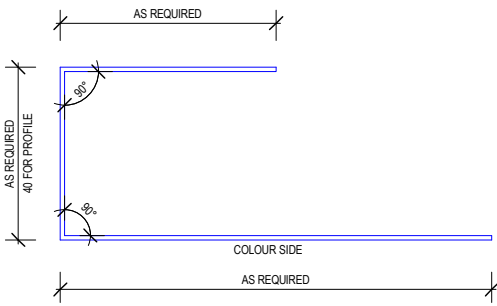

SNA-100 - J Mould Flashing with Squash Fold

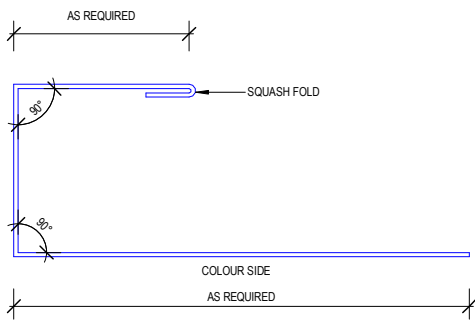
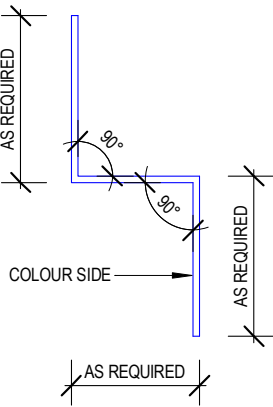

Figure 12.3.5.2:

SNA-101 - Z Mould Flashings



SNA-101 - Z Mould Flashing with 1 Squash Fold

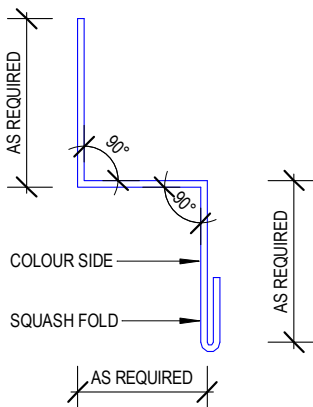
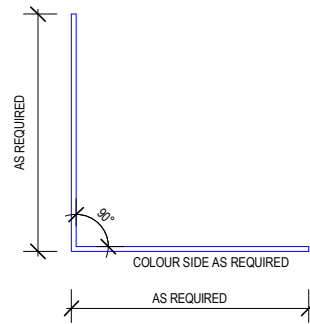
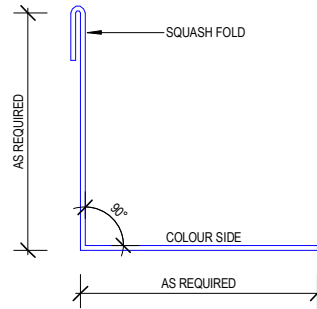

Figure 12.3.5.3:

SNA-102 - L Mould Flashings



SNA-102 - L Mould Flashing with 1 Squash Fold



SNA-102 - L Mould Flashing with Squash Folds

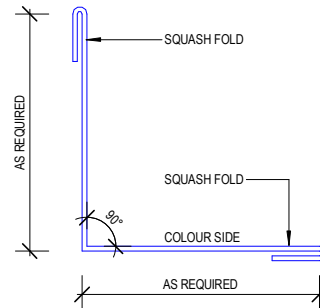

Figure 12.3.5.10:

SNA-204 - Aluminium Base Flashing with Ventilation

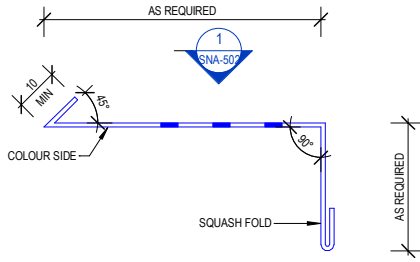

Figure 12.3.5.11:

SNA-205 - Top of Wall Flashing

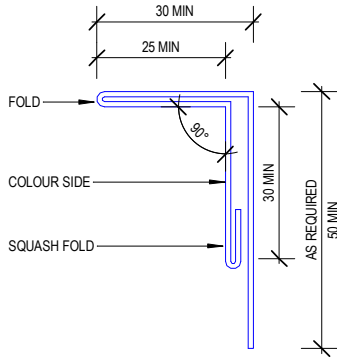
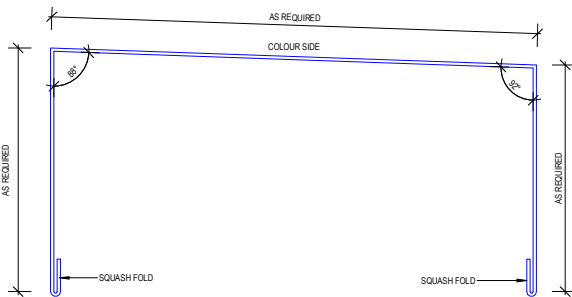

Figure 12.3.5.12:

SNA-206 - Parapet Top Flashing with Squash Folds



SNA-206 - Parapet Top Flashing with Squash Fold and return

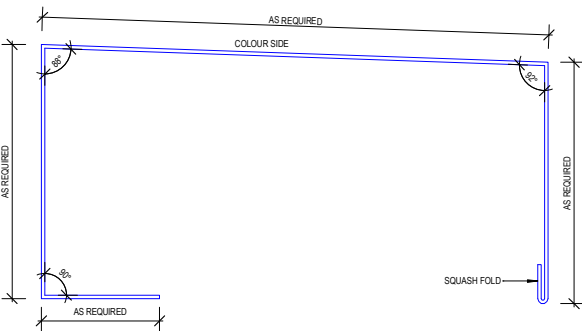

Figure 12.3.5.13:

SNA-300 - Roof Valley Flashing

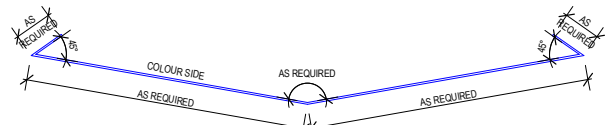
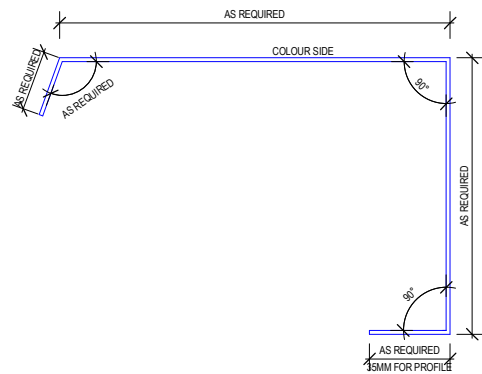

Figure 12.3.5.14:

SNA-301 - Barge Flashing with returns



SNA-301 - Barge Flashing with return and Squash Fold

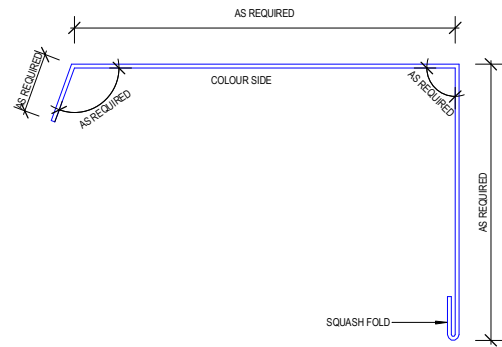

Figure 12.3.5.15:

SNA-302 - Ridge Cap Flashing

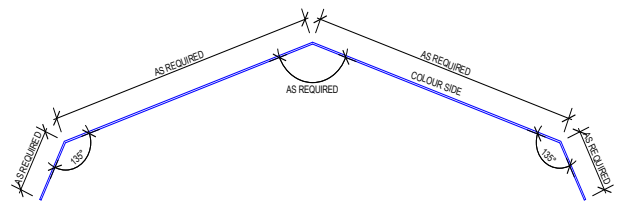

Figure 12.3.5.16:

SNA-400 - Window Sill Flashing with Squash Fold

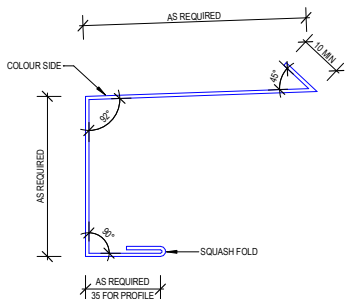

Figure 12.3.5.17:

SNA-401 - Window Head Flashing with Squash Fold

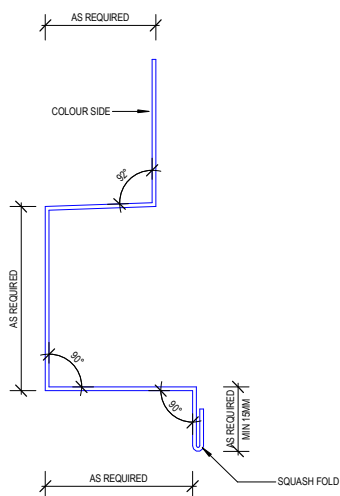

Figure 12.3.5.18:

SNA-402 - Window jamb Flashing with Squash Folds

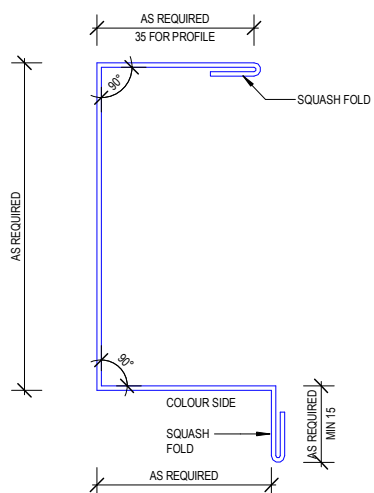

Figure 12.3.5.19:

SNA-403 - Window Z flashing with Squash Fold

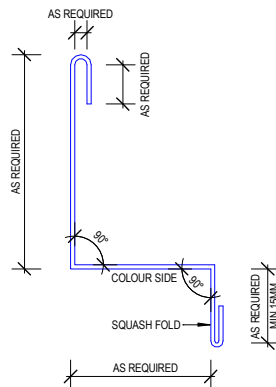
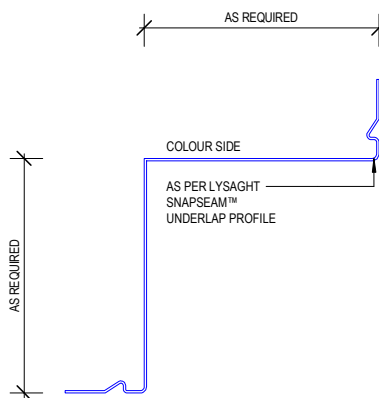
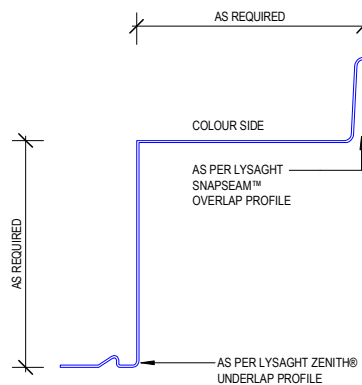

Figure 12.3.5.20:

SNA-500 - External Corner Details - Underlap Underlap



SNA-500 - External Corner Details - Overlap Underlap



SNA-500 - External Corner Details - Overlap Overlap

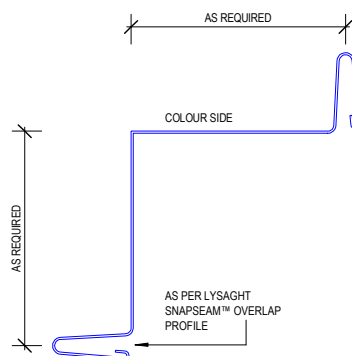
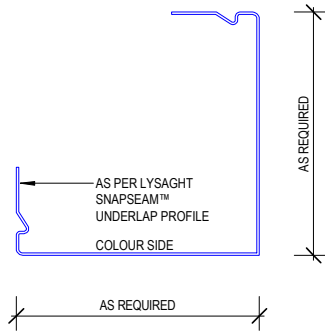
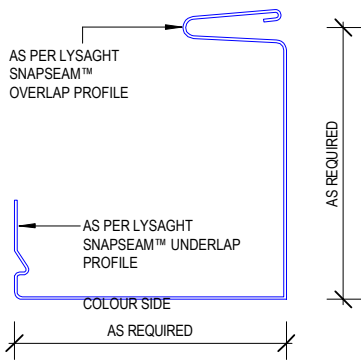

Figure 12.3.5.21:

SNA-501 - Internal Corner Details - Underlap Underlap



SNA-501 - Internal Corner Details - Overlap Underlap



SNA-501 - Internal Corner Details - Overlap Overlap

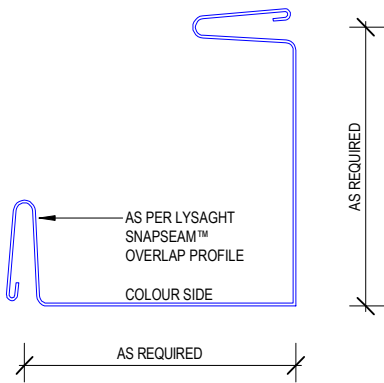

Figure 12.3.5.22:

SNA-502 - Perforation Detail

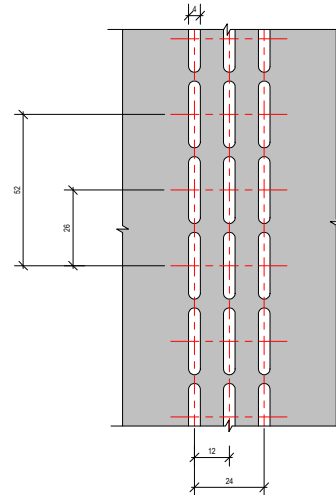
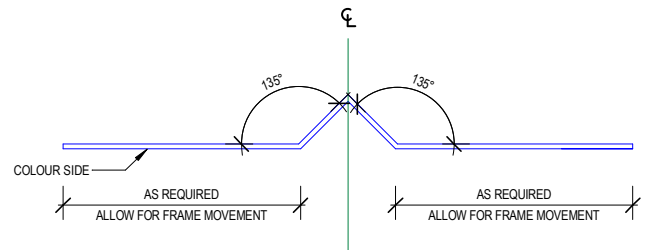

Figure 12.3.5.23:

SNA-503 - Corrosion Resistant Flashing



13.0 DOMINION® wall cladding

DOMINION® architectural panel is a discreet pierce fixed flat panel wall cladding system. DOMINION® is structurally sound for direct fixed to steel battens and can also be fixed onto conventional supporting substrate such as plywood or fibre cement panels.

DOMINION® is a cyclonic wall cladding system installed with a ventilated air space. It involves laying DOMINION® on a metal framework fixed to the supporting structure. The interlocking groove connecting the panels gives an elegant recessed joint.

DOMINION® can be laid vertically or horizontally. The choice of direction implies different aesthetics and technical solutions for the main flashings.

13.1 MATERIAL SPECIFICATIONS

Coverage (mm)	285		
Base Metal Thickness (BMT) (mm)	0.55	0.7*	0.75*
Total Coated Thickness⁽¹⁾ (TCT) (mm)	0.6	0.75	0.8
Rib Height (mm)	25		
Sheet Length⁽²⁾ (mm)			
Minimum	500		
Maximum	8,000 ⁽²⁾		
Mass / Unit Length (kg/m)			
ZINCALUME® steel	1.76	2.25	2.23
COLORBOND® steel ⁽¹⁾	1.78	2.29	2.24
Mass / Unit Area (kg/m²)			
ZINCALUME® steel	5.94	7.51	8.03
COLORBOND® steel ⁽¹⁾	6.07	7.64	8.17
Minimum Yield Strength	300 (G300)		
Coating Class	AM125 - ZINCALUME® steel		
(See Base Material for detail)	AM100 - COLORBOND® steel		
	AM100 - COLORBOND® Metallic steel		
	AM150 - COLORBOND® Ultra steel		
Tolerance	Sheet length: ±3mm Cover width: ±2mm		
Thermal Expansion	2.9mm average per 5m @ 50°C change		

Notes:

- Based on standard, single sided COLORBOND® steel. For other painted steel options please contact your lysaght representative.
- To assist minimising the effects of oil canning in DOMINION® cladding, it is recommended to keep panel length under 8m. Longer length may be available subject to minimum order quantity.

*Please check with your local branch for availability.

MINIMUM ROOF PITCH

DOMINION® is not suitable for roofing.

INSULATION

Care needs to be taken when installing insulation with LYSAGHT DOMINION® cladding. The screws may need to be increased depending on the thickness and density of the insulation. When the screw is properly tightened into metal there should be a minimum of three (3) threads protruding past the support being fixed in to. For timber the screw must have a min embedment of 25mm into the timber.

For insulation, the use of a spacing system is recommended to help maintain R_w values as well as minimising any bulging in the profile caused by the insulation. Refer to oil canning section for potential visual impacts of insulation on the product.

Figure 13.1.2:

DOMINION® profile

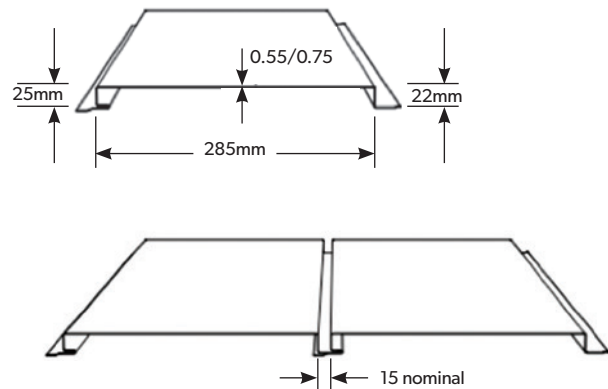

NB Lysaght Dominion panels are available with either open or closed ends. This needs to be specified at order placement.

FASTENING DOMINION® CLADDING TO SUPPORTS

DOMINION® cladding is screw-fixed to supports. Engage the overlap leg into the underlap recess, then fix the nominated fastener through both legs into batten or plywood support. When the screw is properly tightened into metal there should be a minimum of three (3) threads protruding past the support being fixed in to. For timber the screw must have a min embedment of 25mm into the timber.

Table 13.1.1:

Fastener Specification.

Application	Fixing to steel	Fixing to plywood/timber Batten
Cyclonic	10g-16x16 wafter or low profile Hex head metal screw with minimum class 3 coating	10g-12x25 wafter or low profile Hex head type 17 metal screw with minimum class 3 coating

DOMINION®: CYCLONIC LIMIT STATE WIND PRESSURE CAPACITIES (KPA) 0.55MM/0.70MM BMT

Cover width	Support	Design Pressure (kPa)	Application
		Strength	
285mm x 0.55mm BMT	Steel batten: 40mm x 0.75mm BMT G550 Batten Spacing: 450mm (max) Batten Span: 1500mm (max)	4.05	Walling
	* 15mm F11 Structural CD grade ply (for walling applications) Support spacing: 600mm (max) Fastener spacing: 250mm	8.0	Walling
	Kingflor 40mm x 0.75mm BMT G550 substrate support Fastener spacing: 250mm (max) Substrate sheet span: 1200mm (max)	10.5	Walling
285mm x 0.70mm BMT	Steel batten: 61mm x 0.75mm BMT G550 Batten Spacing: 500mm (max) Batten Span: 1500mm (max)	5.8	Walling

Notes:

1. Minimum purlin / support thickness must be 1.50mm BMT
2. *15mm F11 structural grade plywood for pressure requirements - walling
3. *19mm F11 structural grade plywood for impact requirements - walling

Table 13.1.2:

Guide to fastener layout and sheet coverage.

SHEET COVERAGE

285MM

Width of Wall (m)	3	4	5	6	7	8	9	10	11	12	13	14	15	16	17	18	19	20	30	40	50
Number of Sheets	11	15	18	22	25	29	32	36	39	43	46	50	53	57	60	64	67	71	106	141	176

WIDTH COVERED BY 'X' NUMBERS OF SHEETS (M)

285MM

Number of Sheets	3	4	5	6	7	8	9	10	11	12	13	14	15	16	17	18	19	20
Coverage (m)	0.86	1.14	1.43	1.71	2.0	2.28	2.57	2.85	3.14	3.42	3.71	3.99	4.30	4.56	4.85	5.13	5.40	5.70

Figure 13.1.2:

Foam Infill detail.

80mm x 30mm closed cell foam infill cut to size and shape on site as required under parapet, toe mold or corner flashing

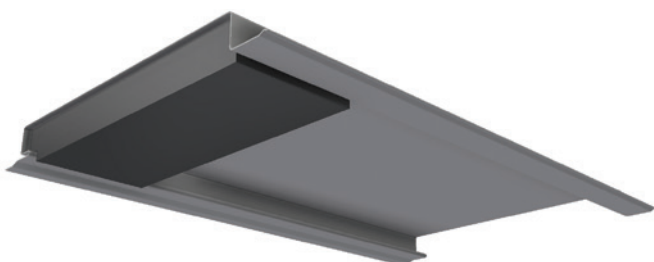

13.2 TYPICAL INSTALLATION DETAILS

FIXING OF THE MEMBRANE

1. Check that the steel work or concrete is free of any sharp edges or protrusions that may puncture the membrane.
2. The membrane must be a heavy duty roof sarking or equivalent with the Sisalation to the outside face.
3. The membrane must be hung and sealed at the top. It must be free of ripples and puckers with holding battens between the 40mm vertical battens securing it to the supporting member. Figure 13.2.5.
4. All laps in the membrane must be made with 150mm lap sealed with double sided tape between the faces of the foil and taped with sisal tape on the outside face.
5. The perimeter of the membrane must be sealed also with premium quality Sisal tape with holding or 40mm battens to secure it. Figure 13.2.7.
6. Note: - It is essential that attention is paid to ensuring that membrane is air tight, fixed in a way that it won't flap or tear away at the laps or edges.
7. At the bottom of the façade a flashing is required to direct any water from the membrane external of the façade. This will be done in a way as to allow any water to pass between the flashing and the foot mould. Figure 13.2.6.

Figure 13.2.1:

Standard fixing detail.

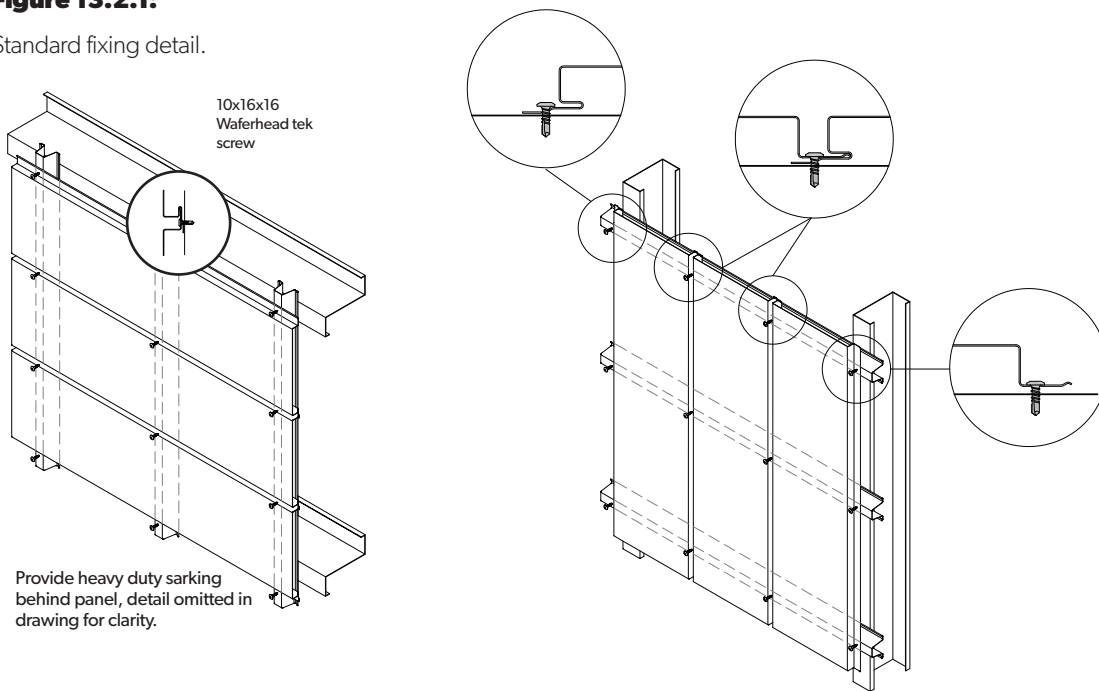

Figure 13.2.2:

Express joint detail.

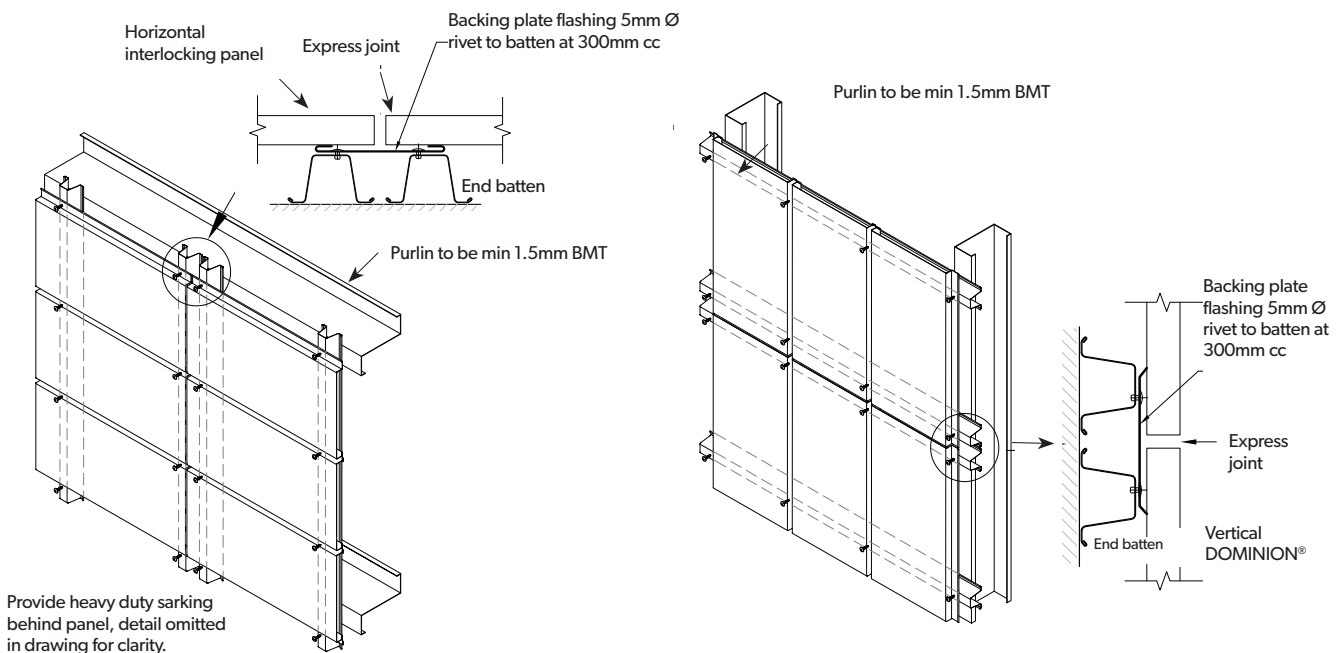
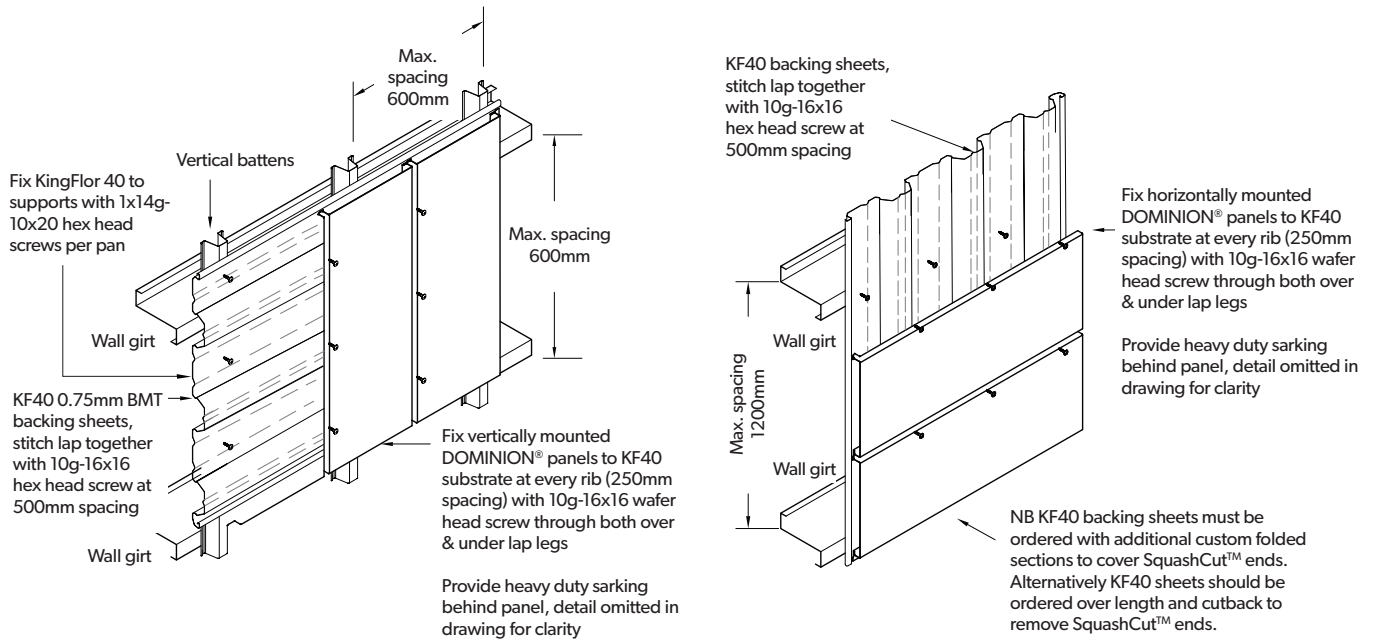
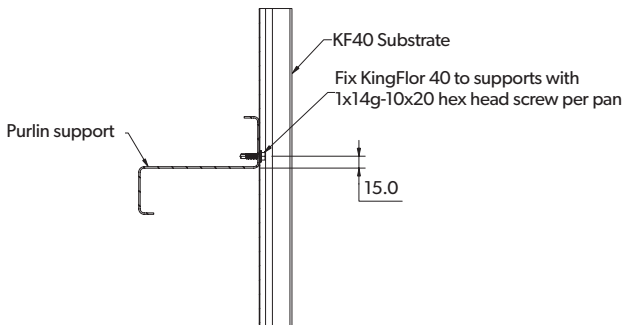

Figure 13.2.3:

KF40 backing detail for applications where resistance to Wind borne debris is required to AS/NZS 1170.2.



Screw location for fixing of vertical KF40 to purlin supports



Screw location for fixing of horizontal KF40 to purlin supports

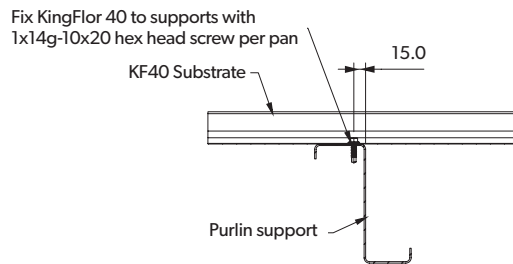

Figure 13.2.4:

Fixing to plywood detail.

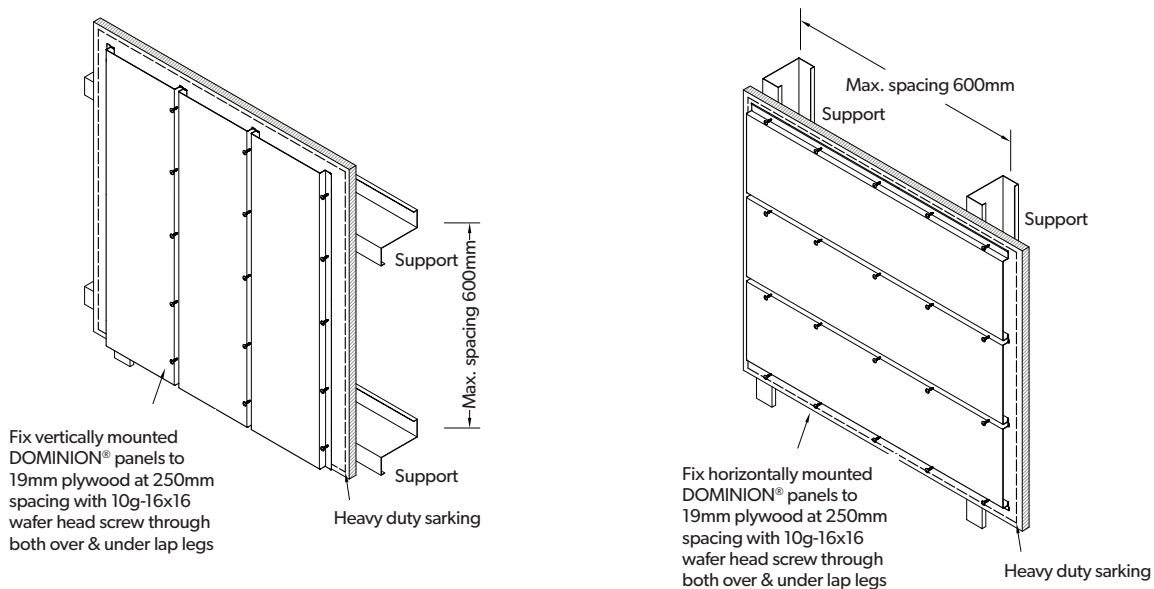

Figure 13.2.5:

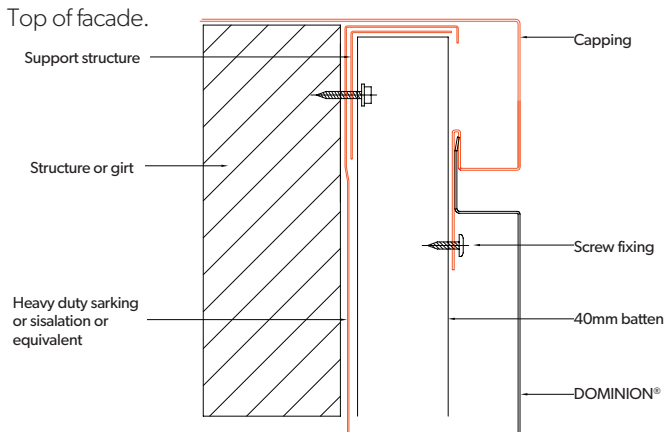

Figure 13.2.6:

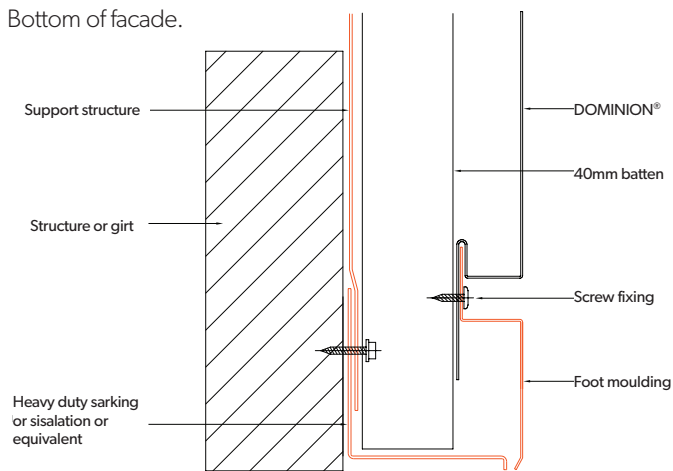

Figure 13.2.7:

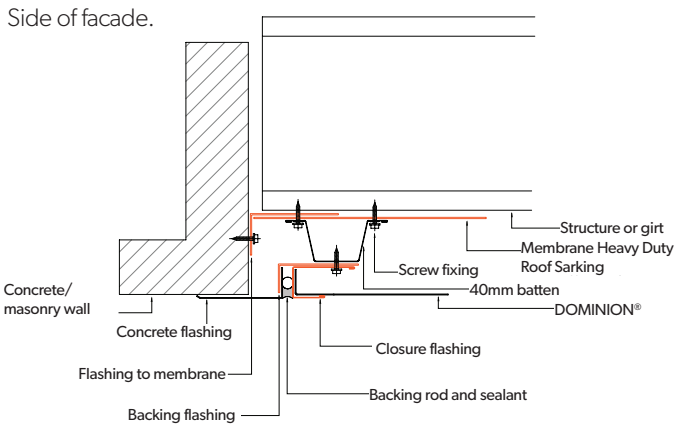

Figure 13.2.8:

Corner flashings.

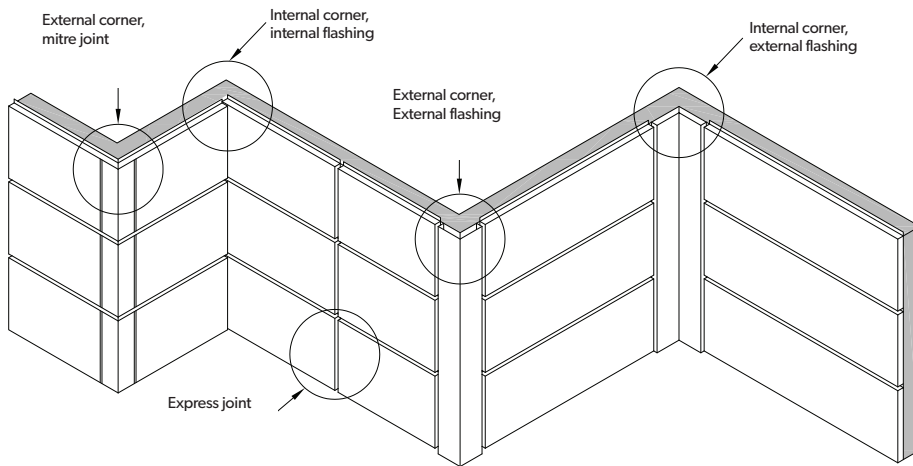

Figure 13.2.9:

External corner external flashing.

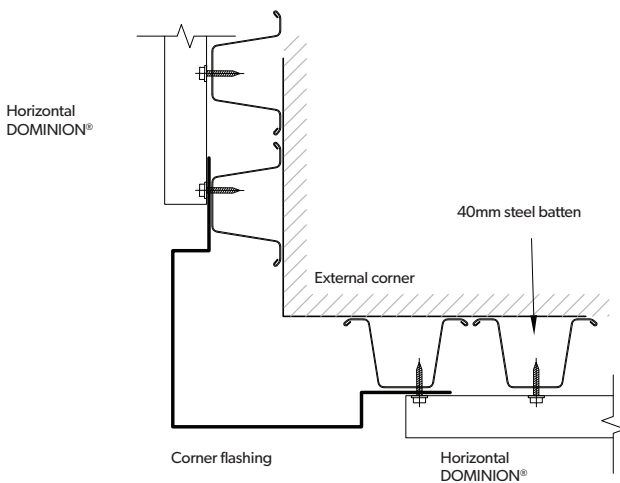
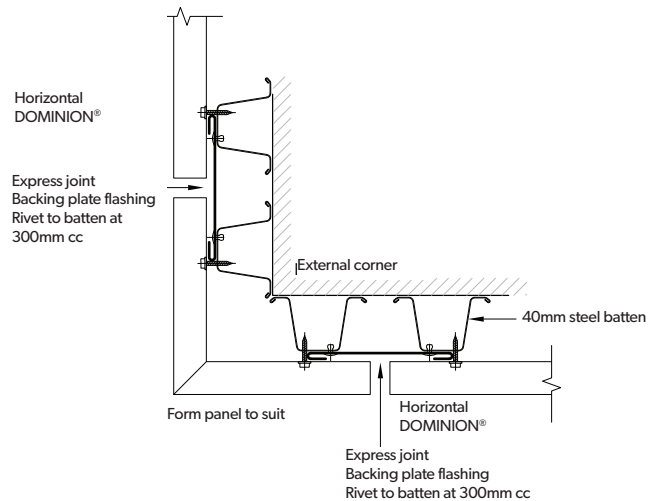

Figure 13.2.11:

External corner mitre cut.



Note: Heavy duty roof sarking detail has been omitted for clarity.

Figure 13.2.10:

Internal corner external flashing.

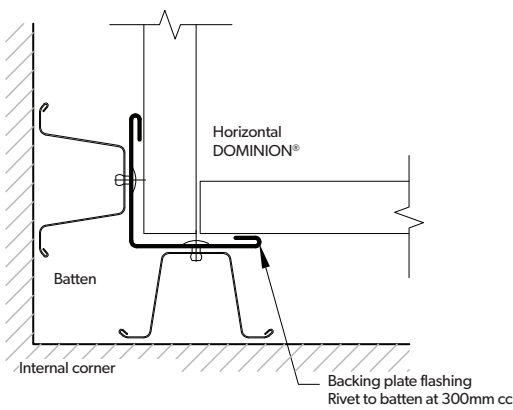

Figure 13.2.12:

Internal corner external flashing.

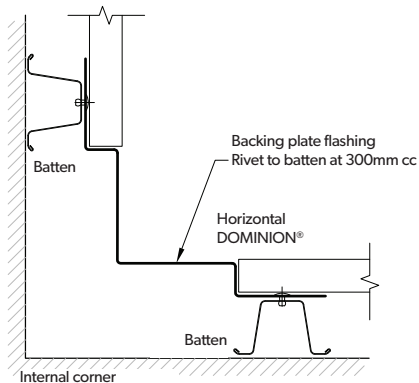

Figure 13.2.13:

Cyclonic fixing to plywood support.

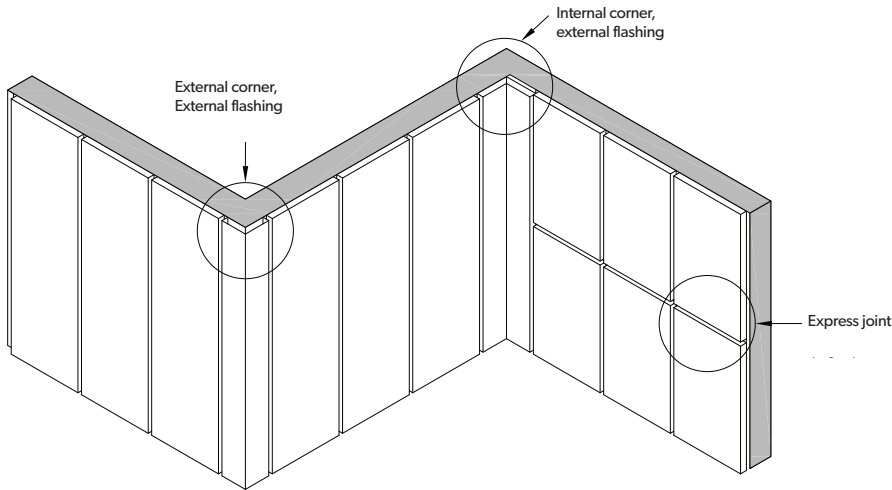

Figure 13.2.14:

External corner flashing.

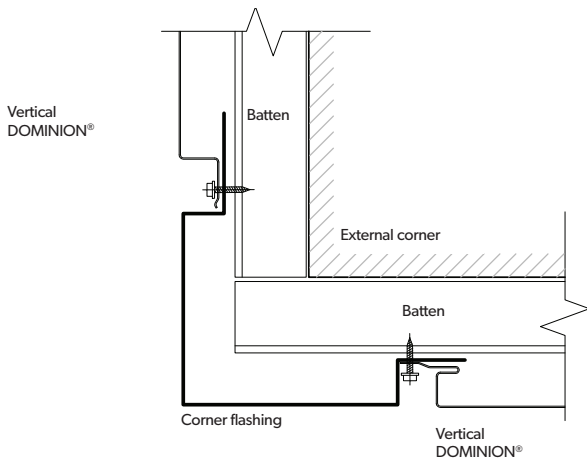
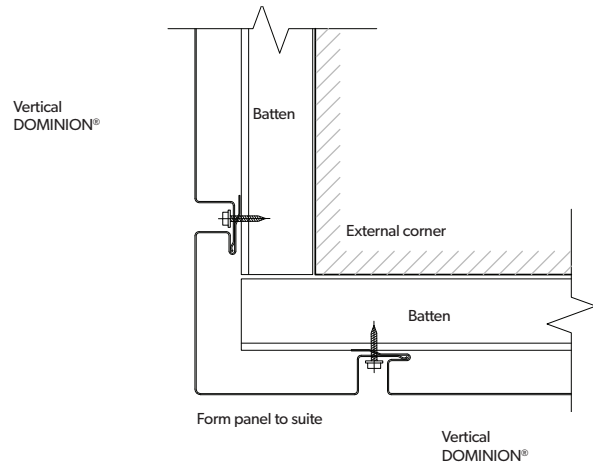

Figure 13.2.16:

External corner formed panel.



Note: Heavy duty roof sarking detail has been omitted for clarity.

Figure 13.2.15:

Internal corner formed panel.

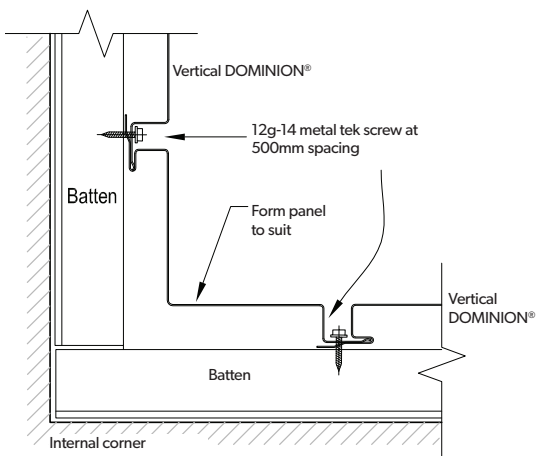

Figure 13.2.17:

Internal corner flashing.

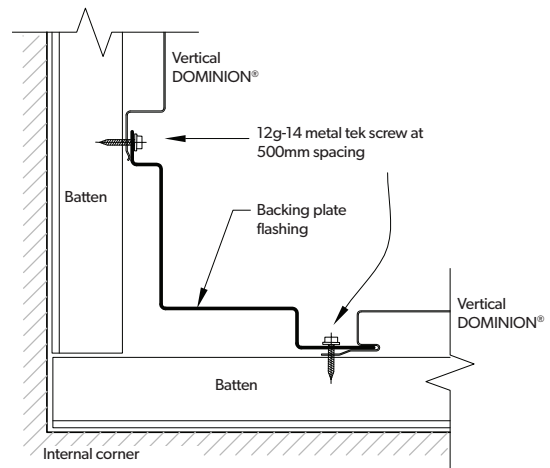

Figure 13.2.18:

Parapet flashing detail.

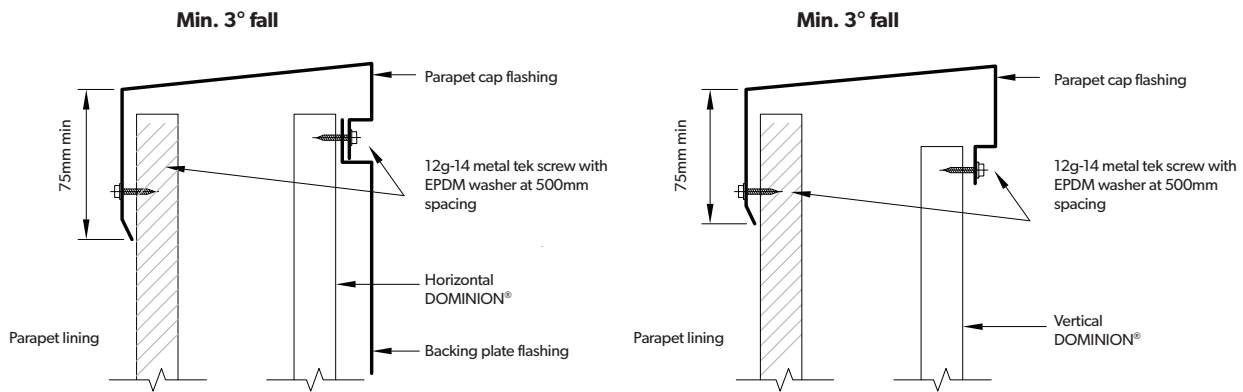

Figure 13.2.19:

Edge detail.

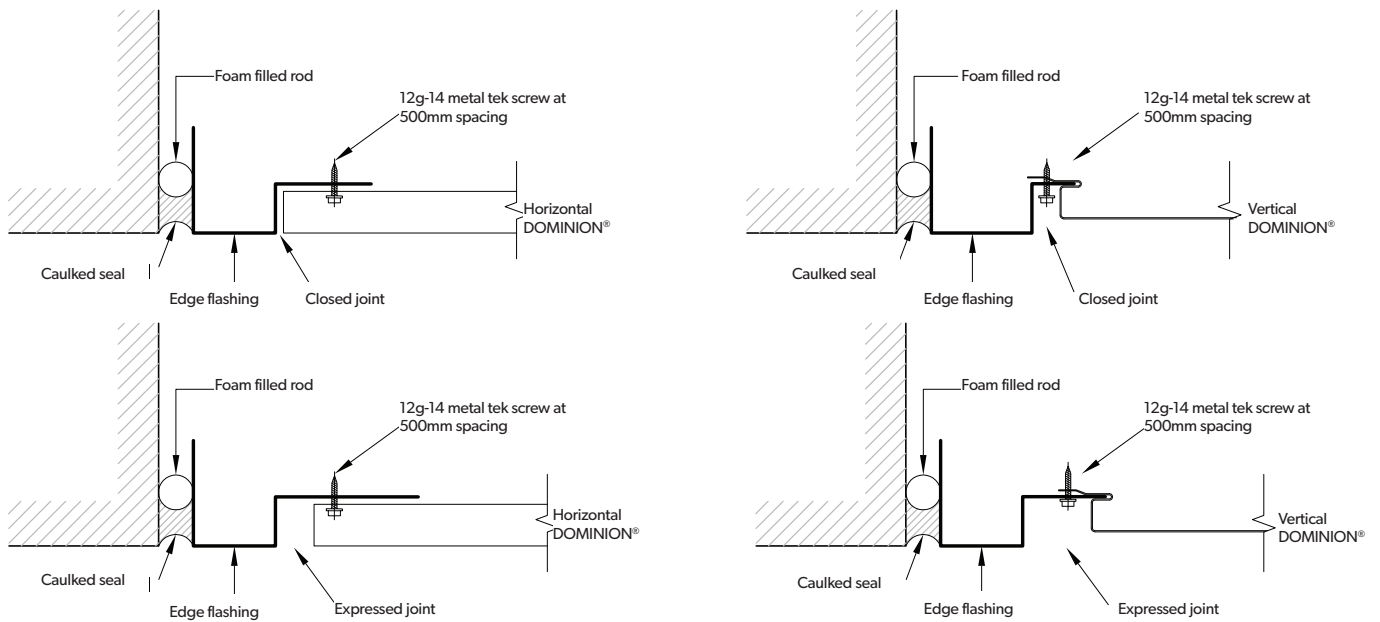
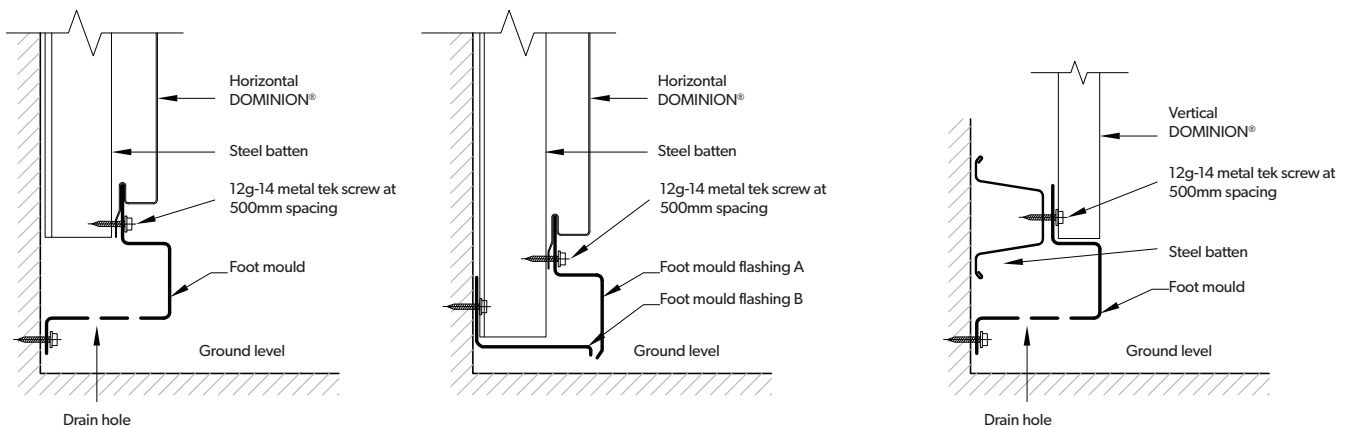

Figure 13.2.20:

Foot Mould detail.



Note: Heavy duty roof sarking detail has been omitted for clarity.

Figure 13.2.21:

Flashing around opening – vertical panel

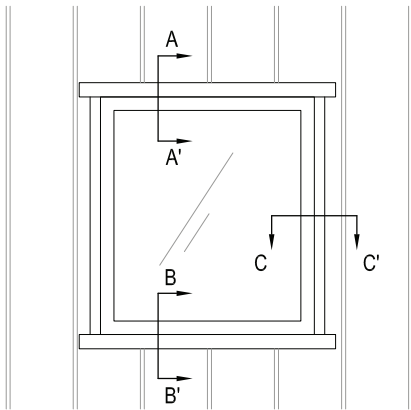

A-A'
Head and sill flashings to be turned up and down behind jamb flashing

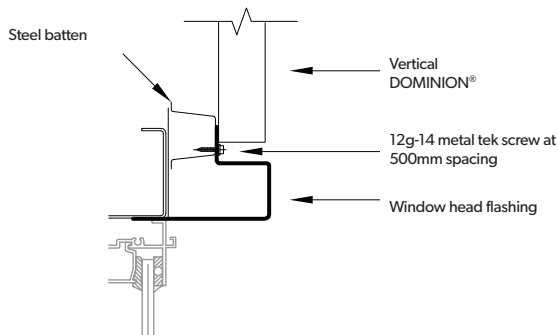

B-B'

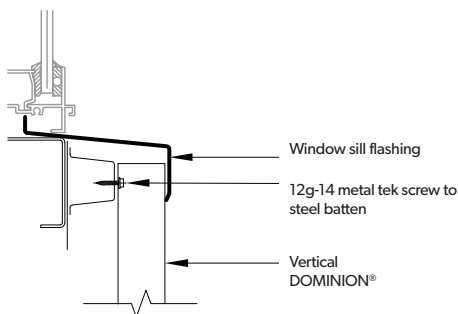

C-C'
Flashing fixed prior to panel, if not fixed through express joint

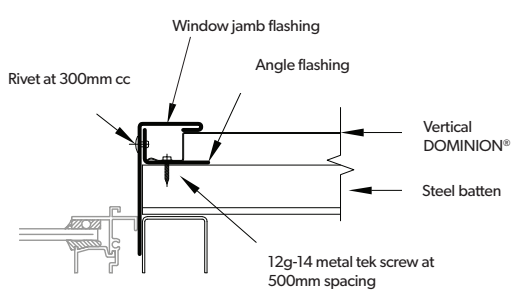
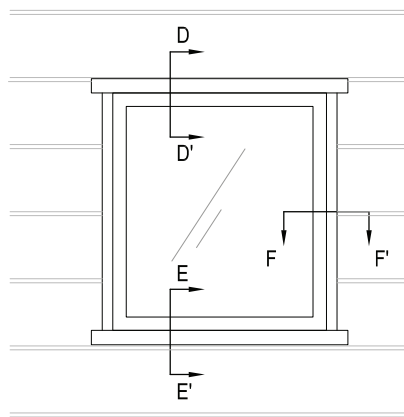
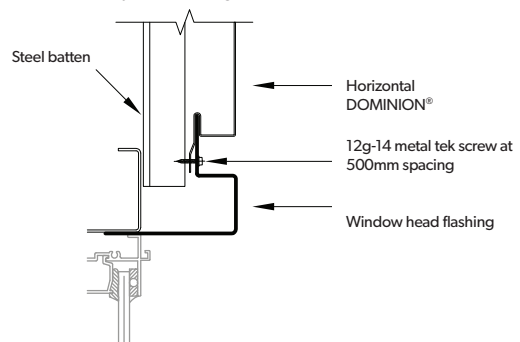

Figure 13.2.22:

Flashing around opening – horizontal panel



D-D'
Head and sill flashings to be turned up and down behind jamb flashing



E-E'

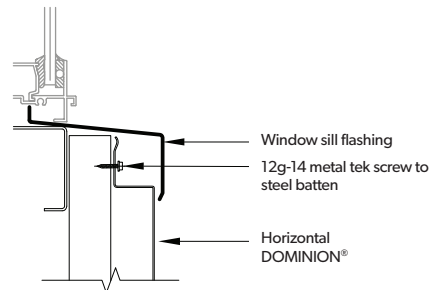

F-F'
Flashing fixed prior to panel, if not fixed through express joint

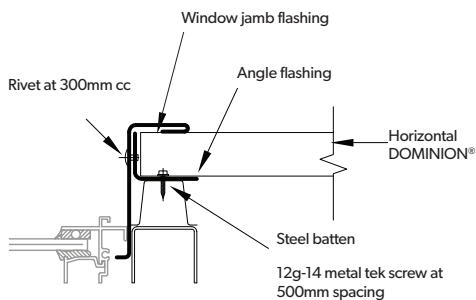

13.3 TYPICAL CONSTRUCTION DETAILS DOMINION®

The construction details presented here represent potential detailing solutions to common construction situations. These details may not be suitable for all projects / situations and users should use professional judgement in determining suitability of the details for their particular project whilst referencing AS 1562.1 and SA HB39. The full suite of ZENITH® constructions details are available for download from <https://bimcontent.com/lysaght/> in both REVIT and PDF format.

13.3.1 DOMINION® TYPICAL WALL DETAILS - HORIZONTAL FIX

Figure 13.3.1.1:

Typical Wall Cladding Setout - Unsupported DOMINION® Panel - Horizontal Fix - Plan View - D04-01

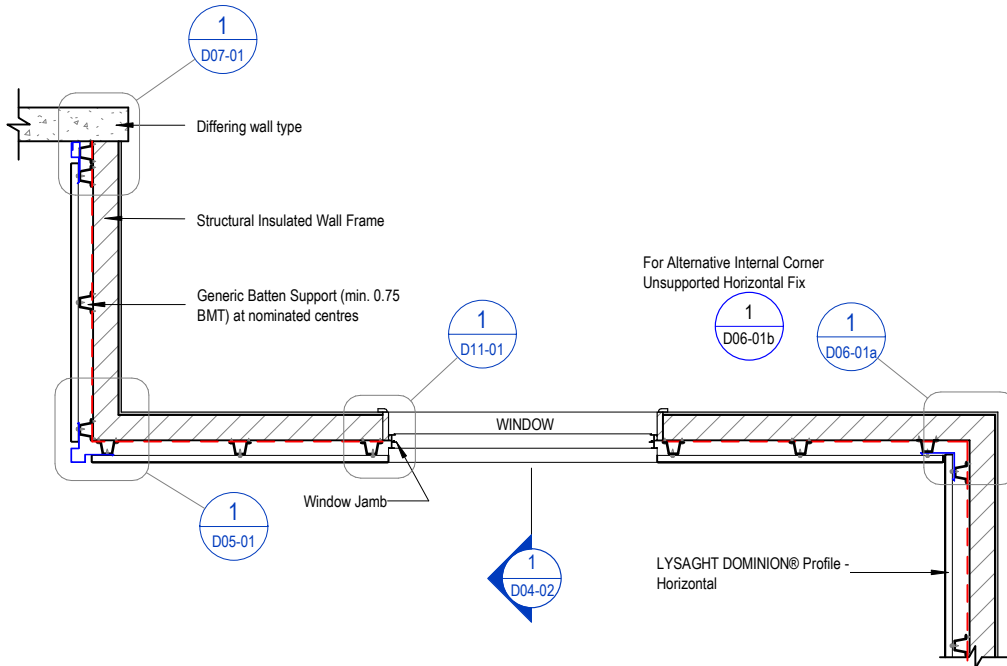

Figure 13.3.1.2:

Typical Wall Cladding Setout - Unsupported DOMINION® - Horizontal Fix - Sectional View - D04-02

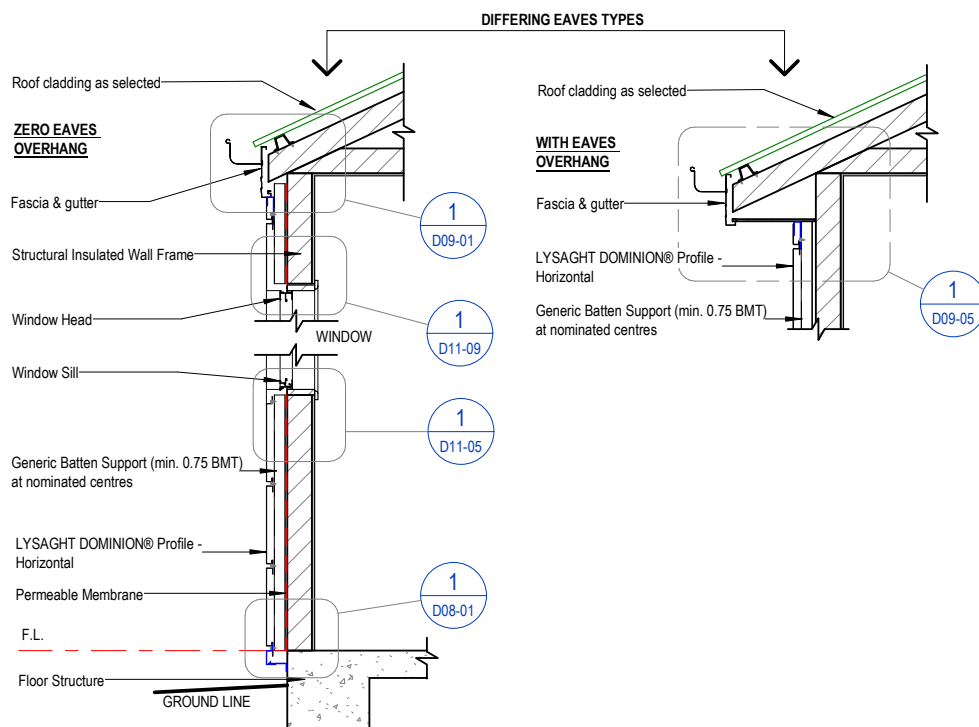

Figure 13.3.1.3:

External Corner - Unsupported DOMINION® Panel - Horizontal Fix - D05-01

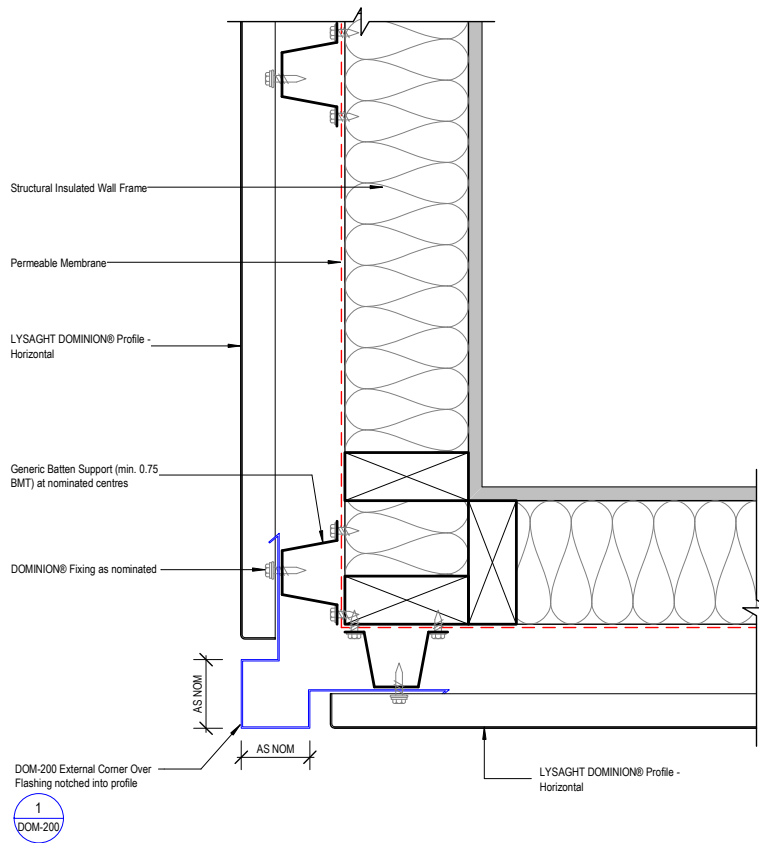

Figure 13.3.1.4:

Internal Corner - Unsupported DOMINION® Panel - Horizontal Fix - D06-01

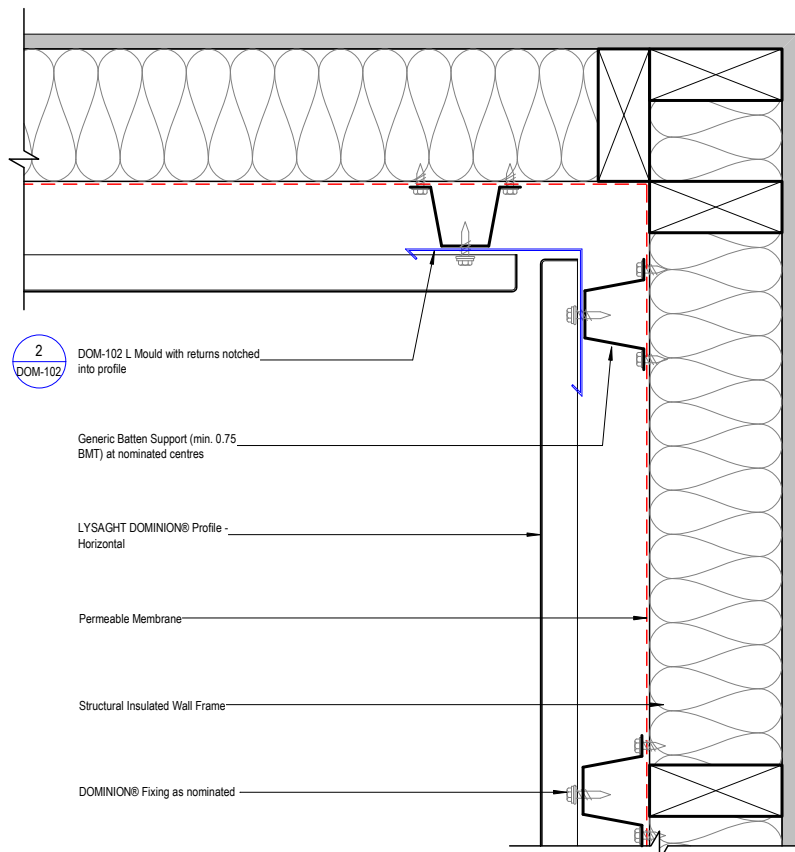

Figure 13.3.1.5:

Wall Closure Detail - Unsupported DOMINION® Panel - Horizontal Fix - D07-01

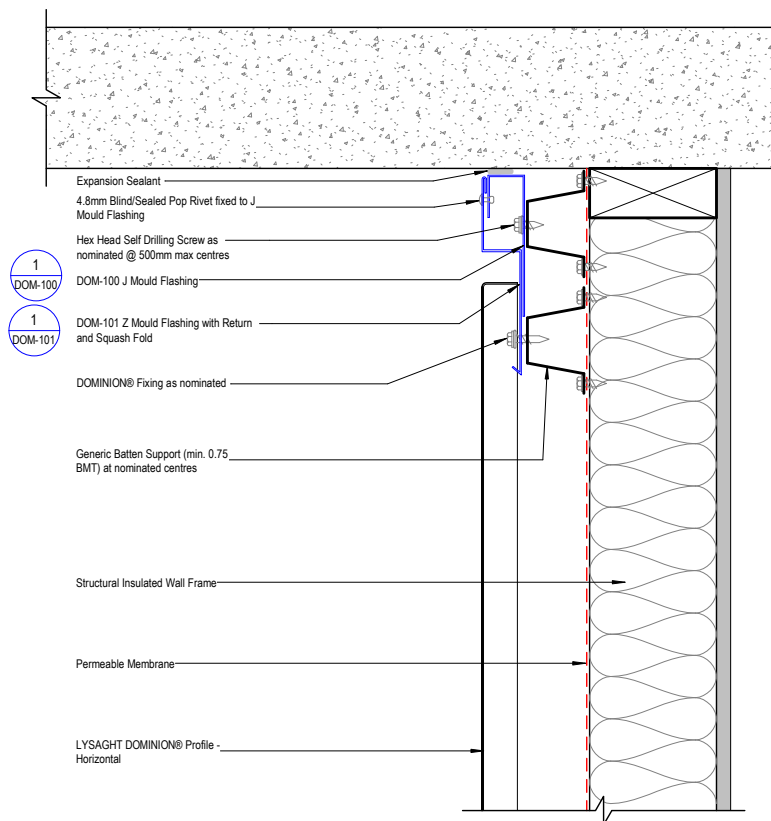

Figure 13.3.1.6

Window Jamb Detail - Unsupported DOMINION® Panel - Horizontal Fix - D11-01

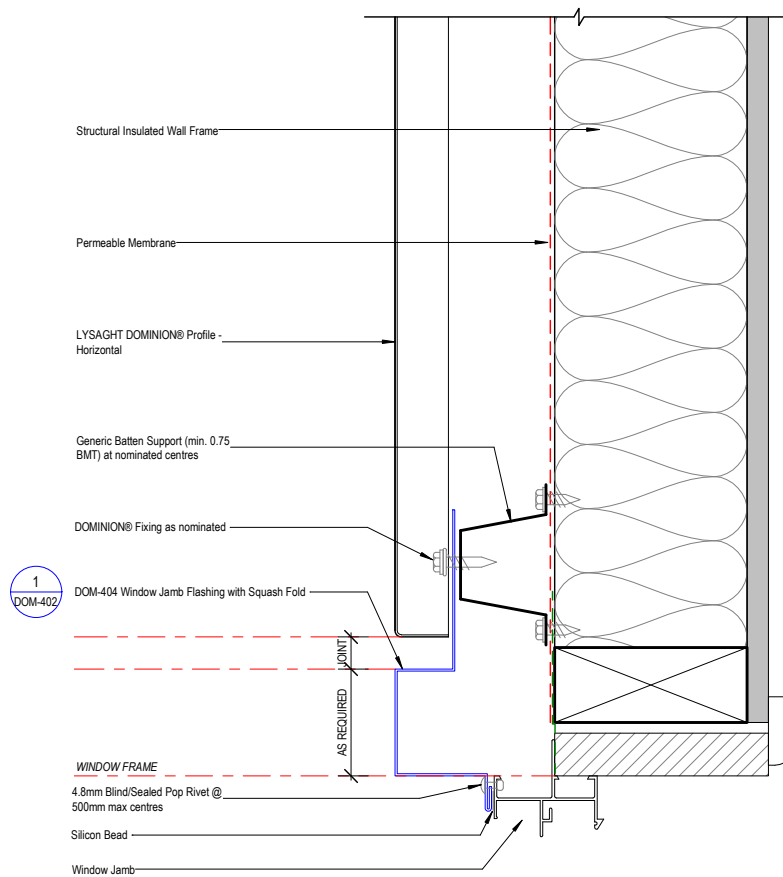

Figure 13.3.1.7:

Wall Base Detail - Unsupported DOMINION® Panel - Horizontal Fix - D08-01

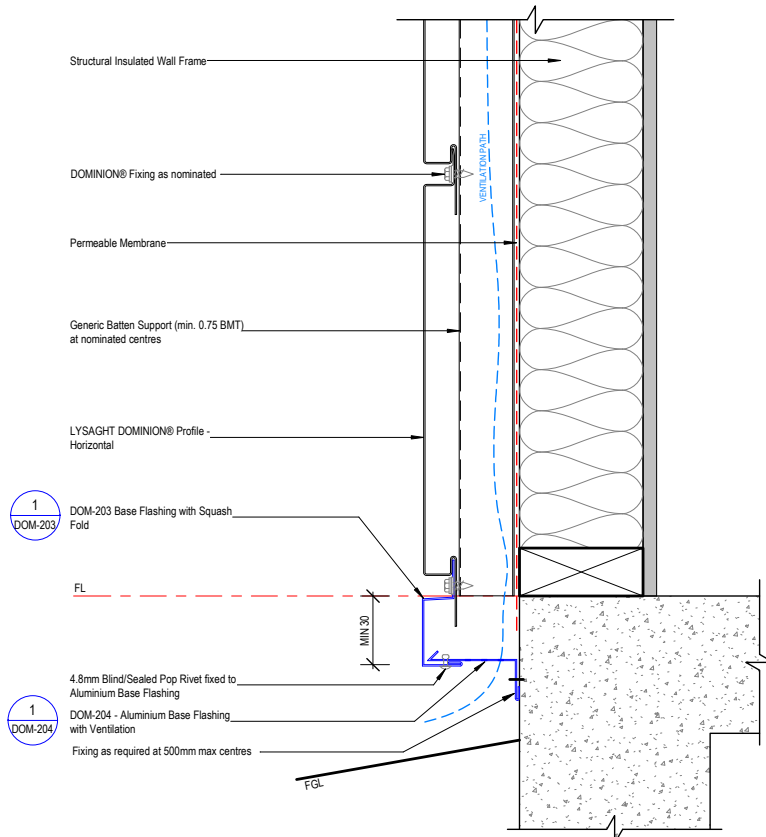

Figure 13.3.1.8:

Top of Wall Eave - Zero Overhang - Unsupported DOMINION® - Horizontal Fix - D09-01

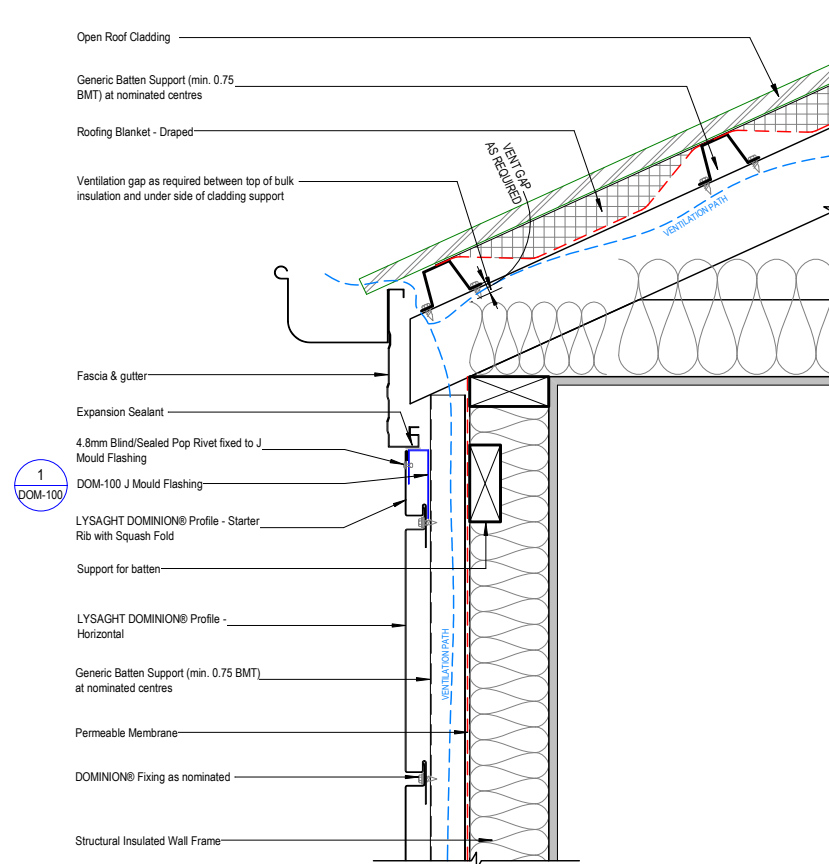

Figure 13.3.1.9:

Top of Wall Eave - Overhang - Unsupported DOMINION® - Horizontal Fix - D09-05

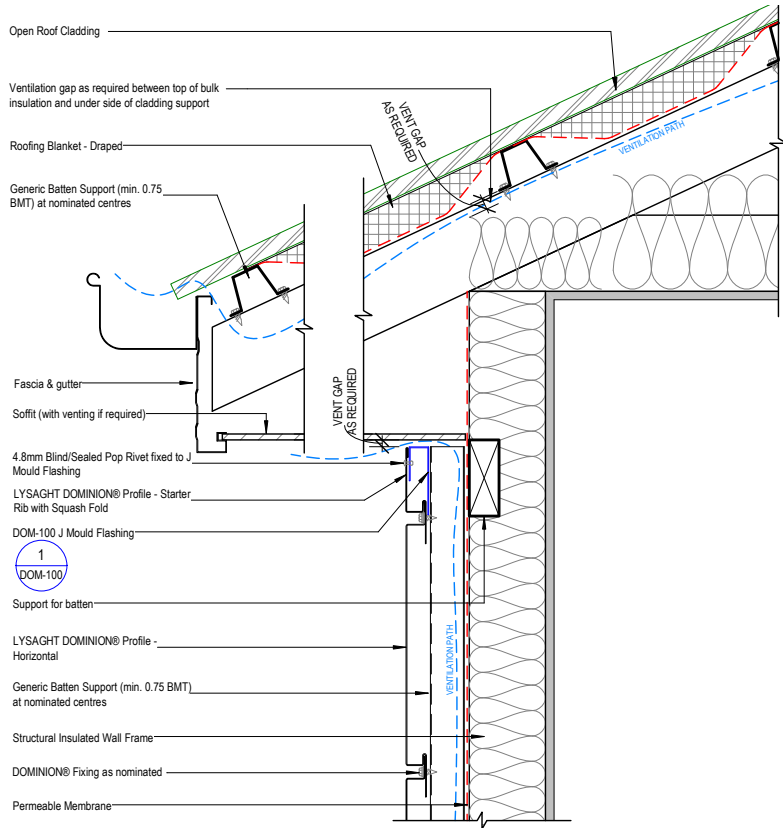

Figure 13.3.1.10

Window Sill Detail - Unsupported DOMINION® Panel - Horizontal Fix - D11-05

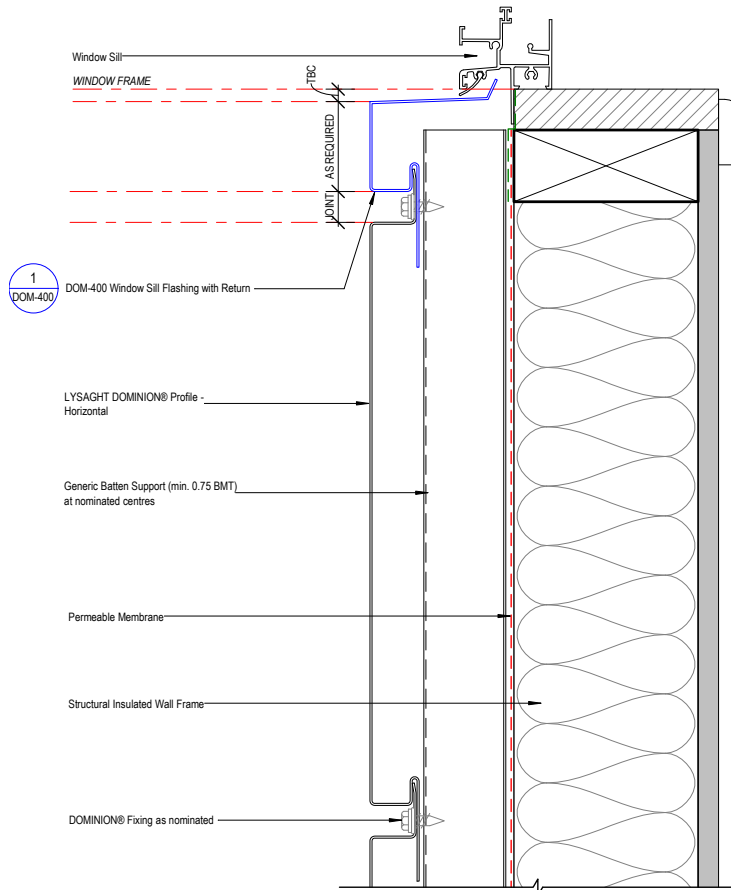
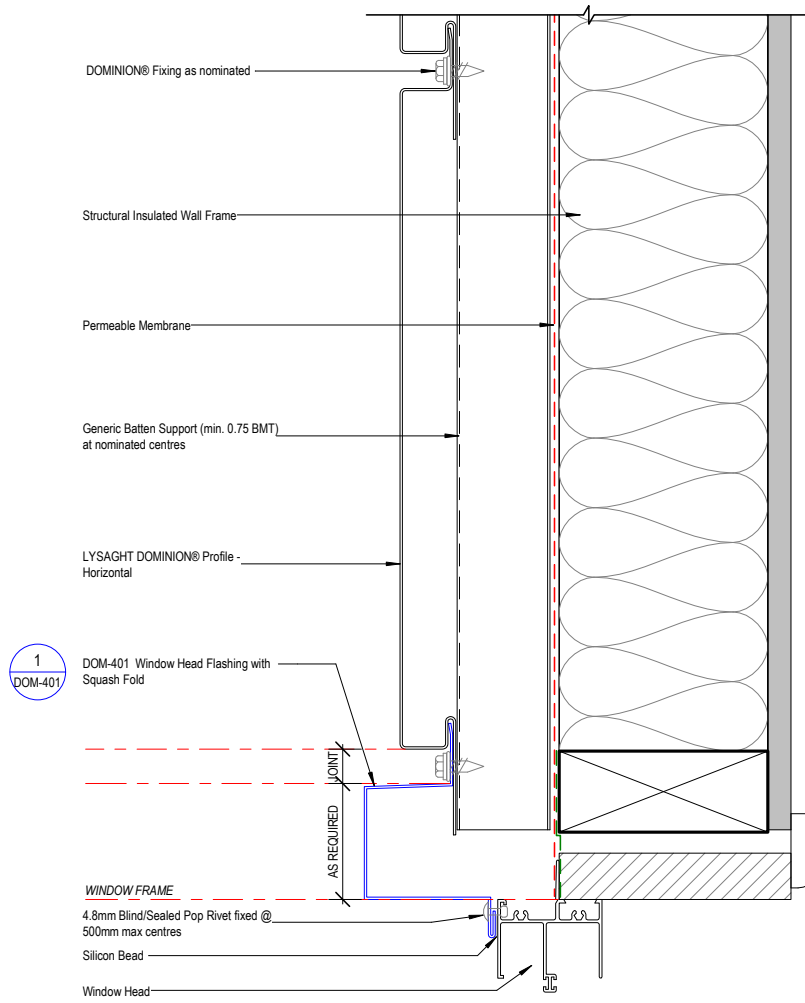

Figure 13.3.1.11:

Window Head Detail - Unsupported DOMINION® Panel - Horizontal Fix - D11-09



13.3.2 DOMINION® TYPICAL WALL DETAILS - VERTICAL FIX

Figure 13.3.2.1:

Typical Wall Cladding Setout - Unsupported DOMINION® Vertical Fix - Plan View - D04-05

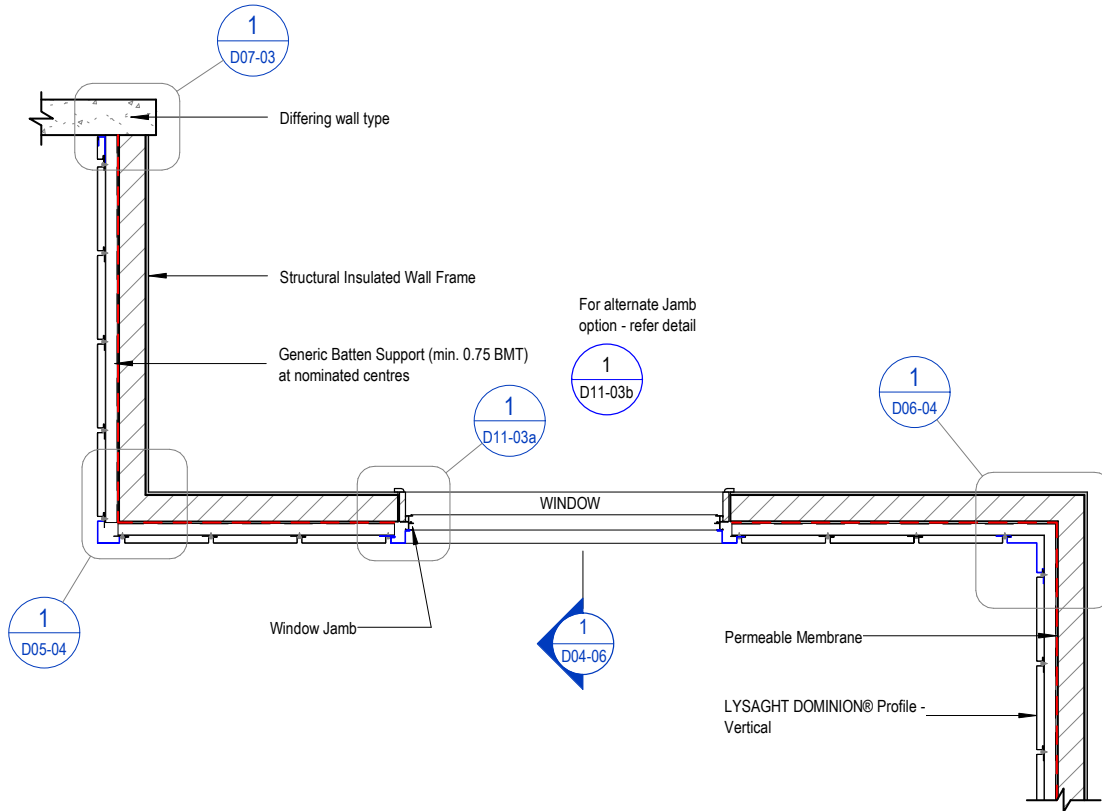

Figure 13.3.2.2:

Typical Wall Cladding Setout - Unsupported DOMINION® - Vertical Fix - Sectional View - D04-06

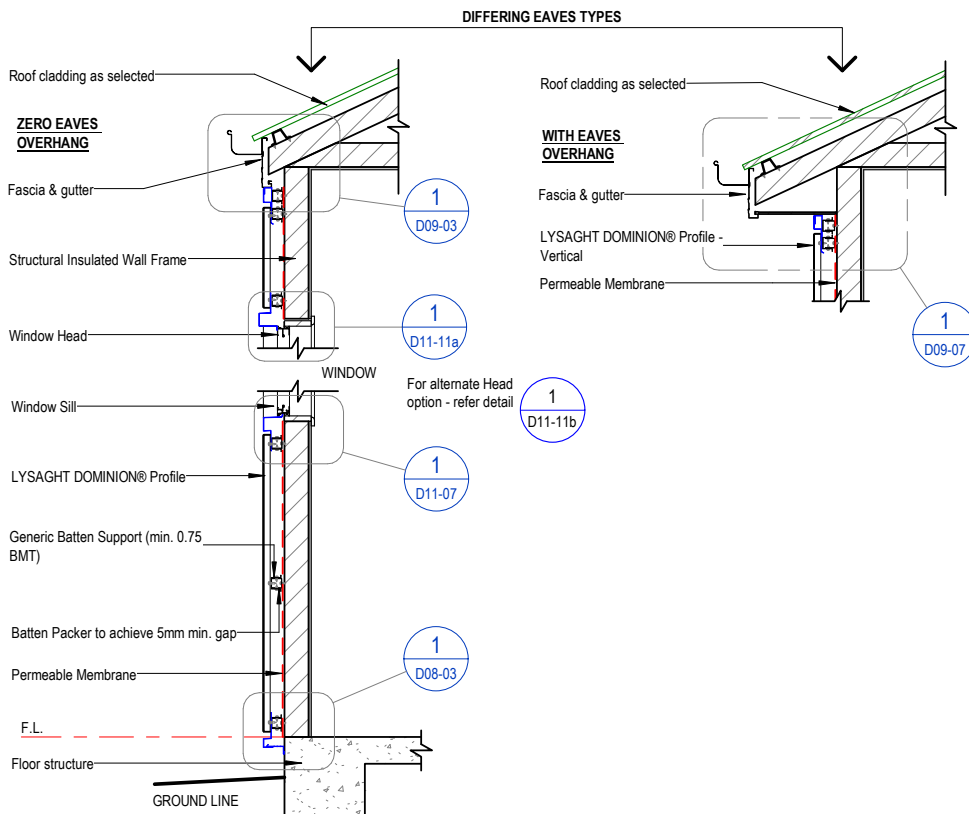

Figure 13.3.2.3:

External Corner - Unsupported DOMINION® Panel - Vertical Fix - D05-04

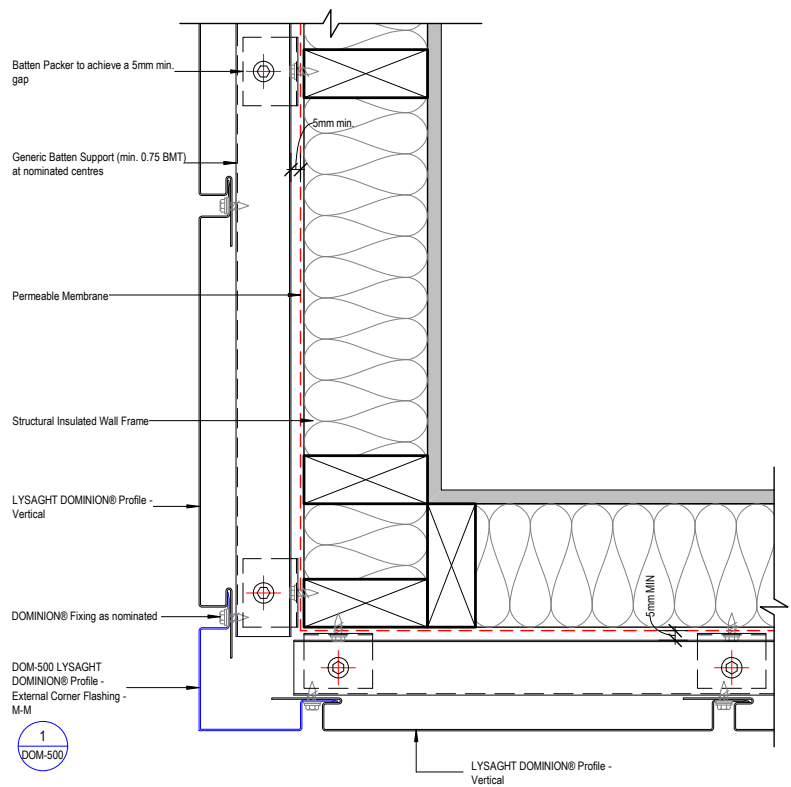

Figure 13.3.2.4:

Internal Corner - Unsupported DOMINION® Panel - Vertical Fix - D06-04

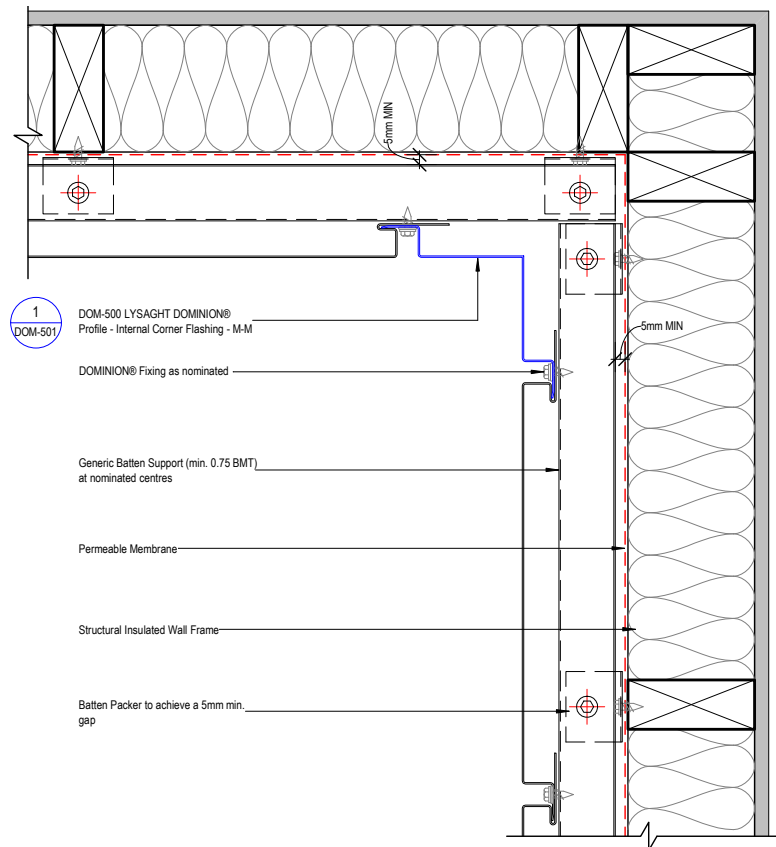

Figure 13.3.2.5:

Wall Closure Detail - Unsupported DOMINION® Panel - Vertical Fix - D07-03

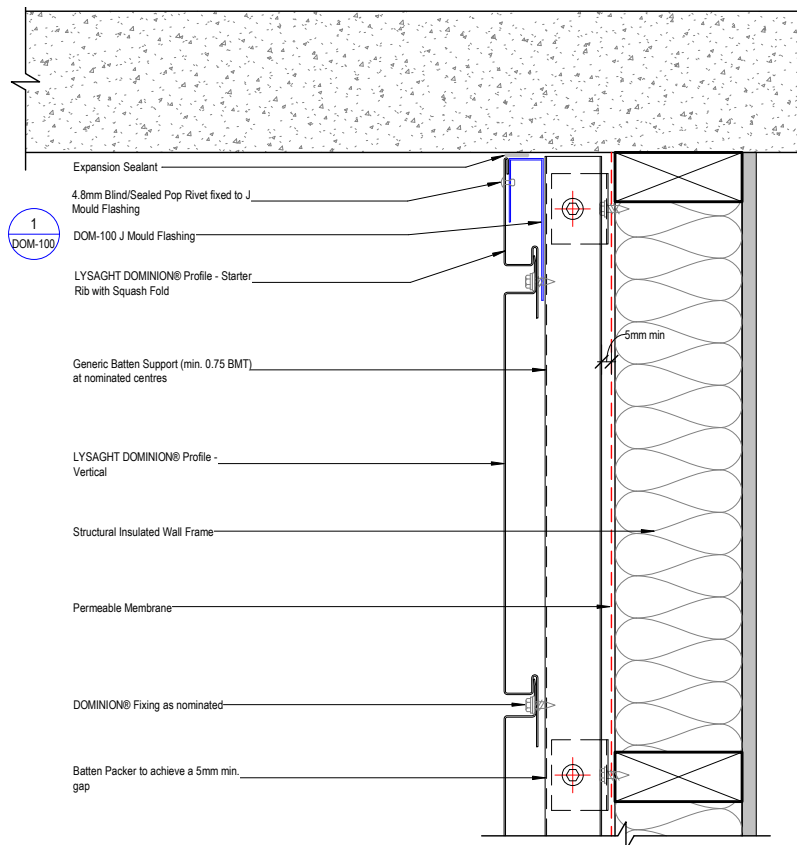

Figure 13.3.2.6

Window Jamb Detail - Unsupported DOMINION® Panel - Vertical Fix - Male - D11-03a

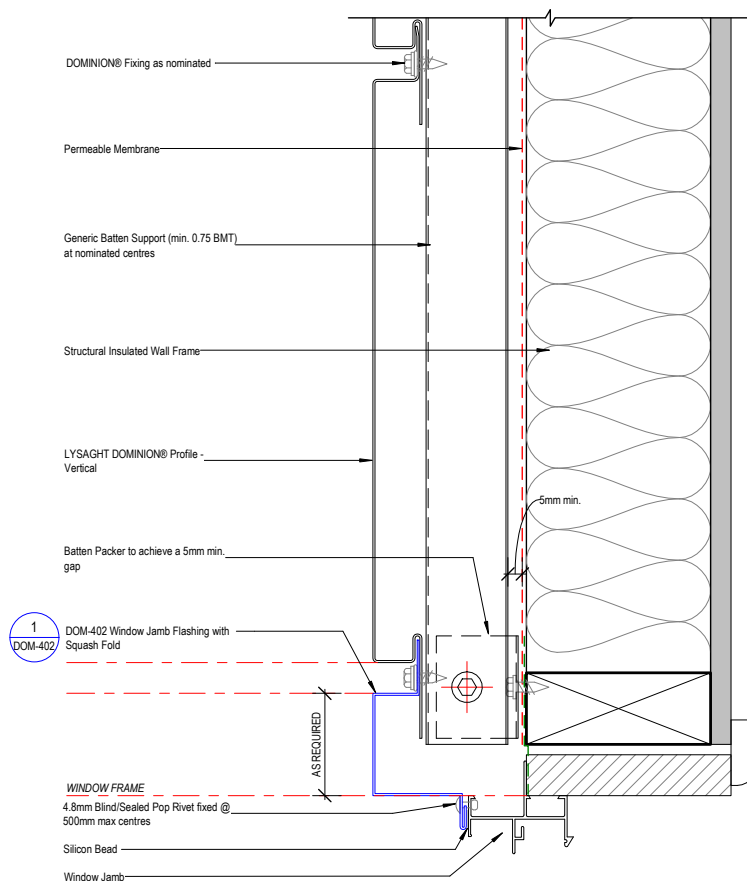

Figure 13.3.2.7:

Window Jamb Detail - Unsupported DOMINION® Panel - Vertical Fix - Female - D11-03b

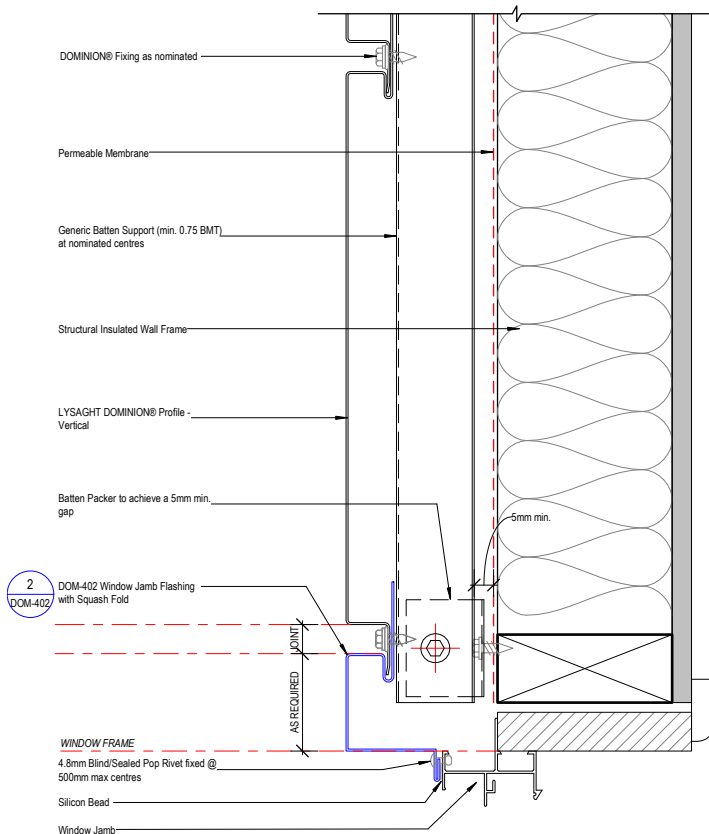

Figure 13.3.2.8:

Wal Base Detail - Unsupported DOMINION® Panel - Vertical Fix - D08-03

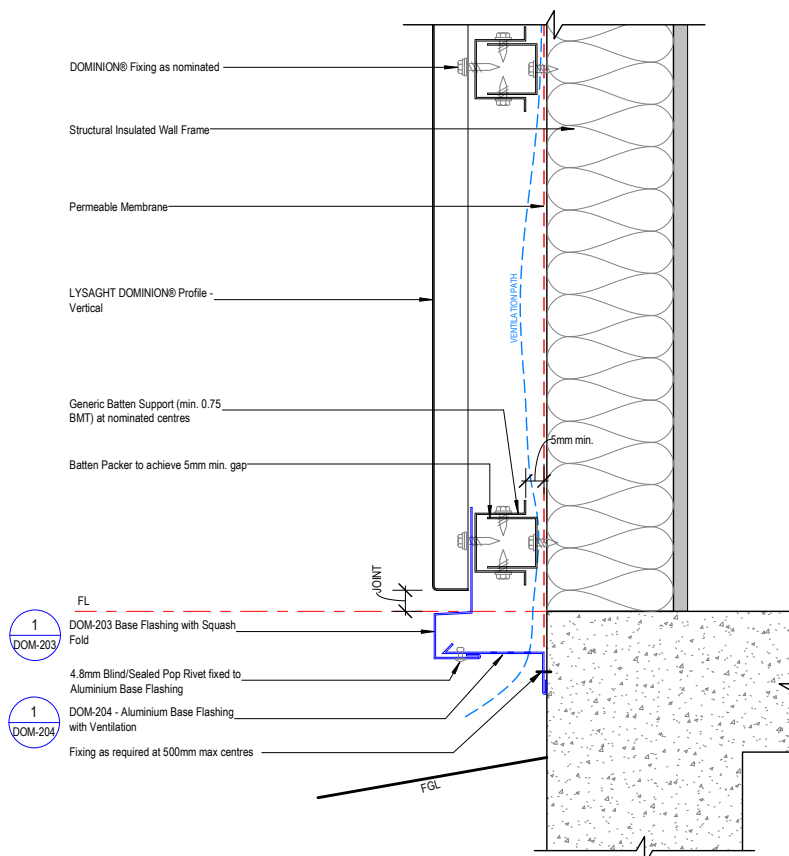

Figure 13.3.2.9:

Top of Wall Eave - Zero Overhang - Unsupported DOMINION® Panel - Vertical Fix - D09-03

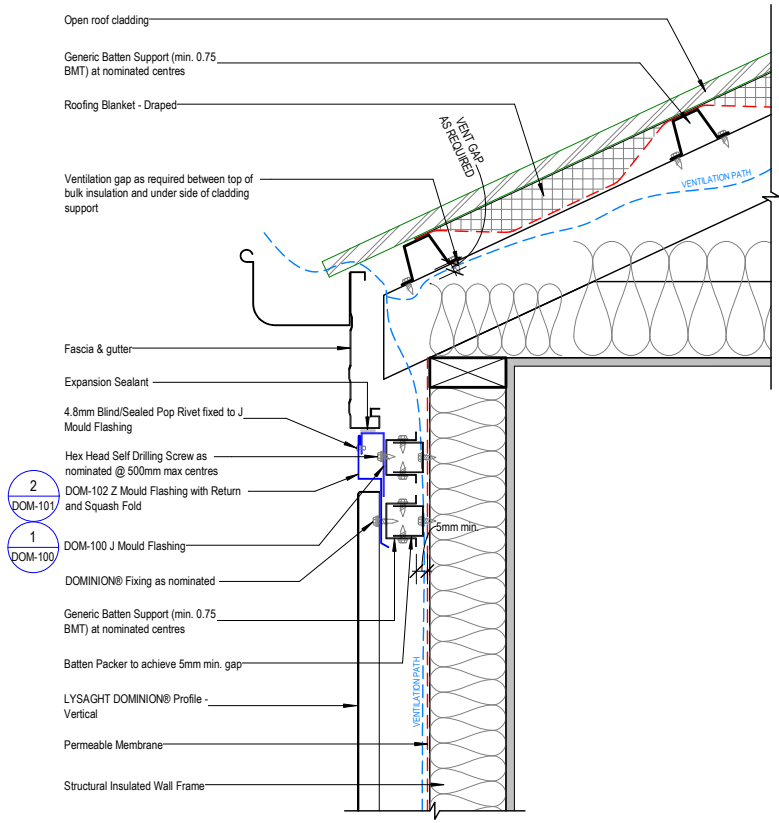

Figure 13.3.2.10

Top of Wall Eave - Overhang - Unsupported DOMINION® Panel - Vertical Fix - D09-07

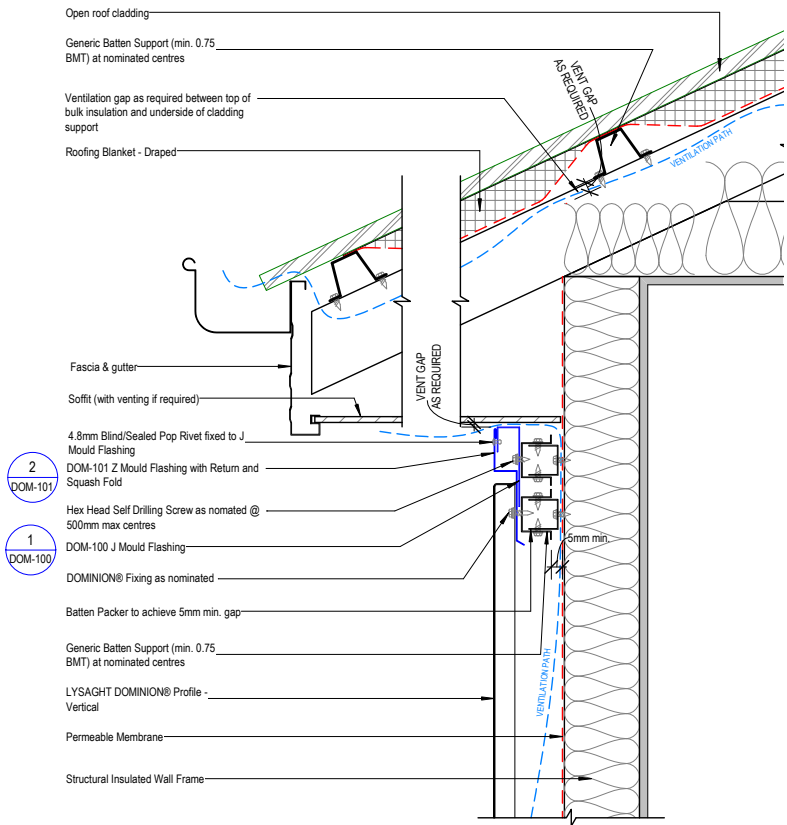

Figure 13.3.2.11:

Window Sill Detail - Unsupported DOMINION® Panel - Vertical Fix - D11-07

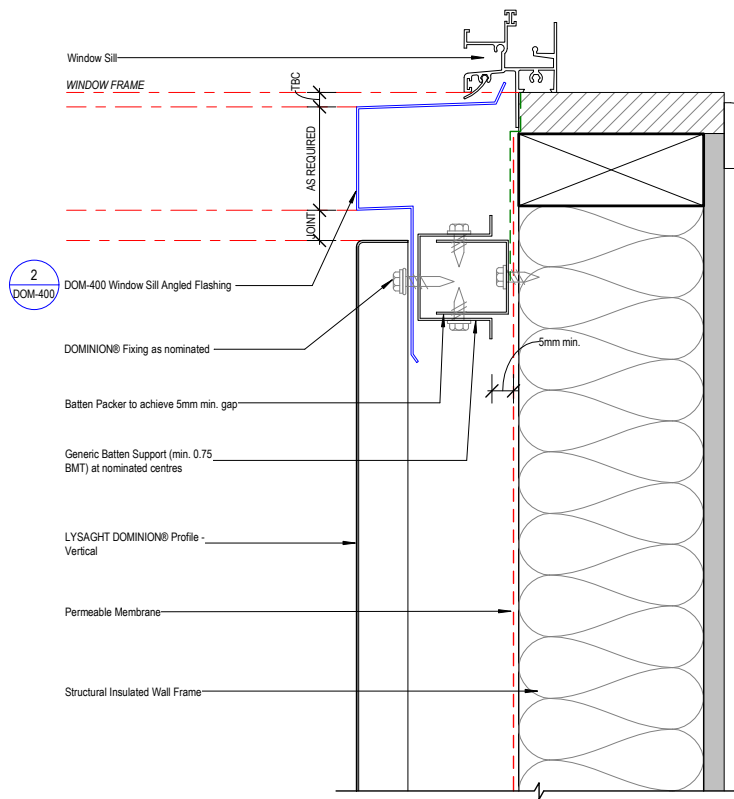

Figure 13.3.2.12:

Window Head Detail - Unsupported DOMINION® Panel - Vertical Fix Option 1 - D11-11a

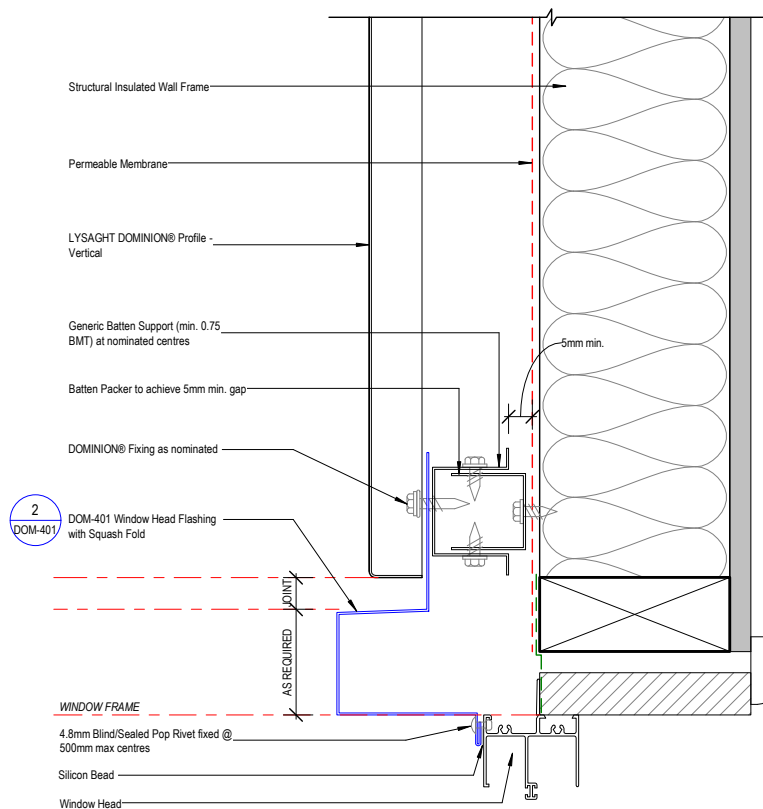

Figure 13.3.2.13:

Window Head Detail - Unsupported DOMINION® Panel - Vertical Fix Option 2 - D11-11b

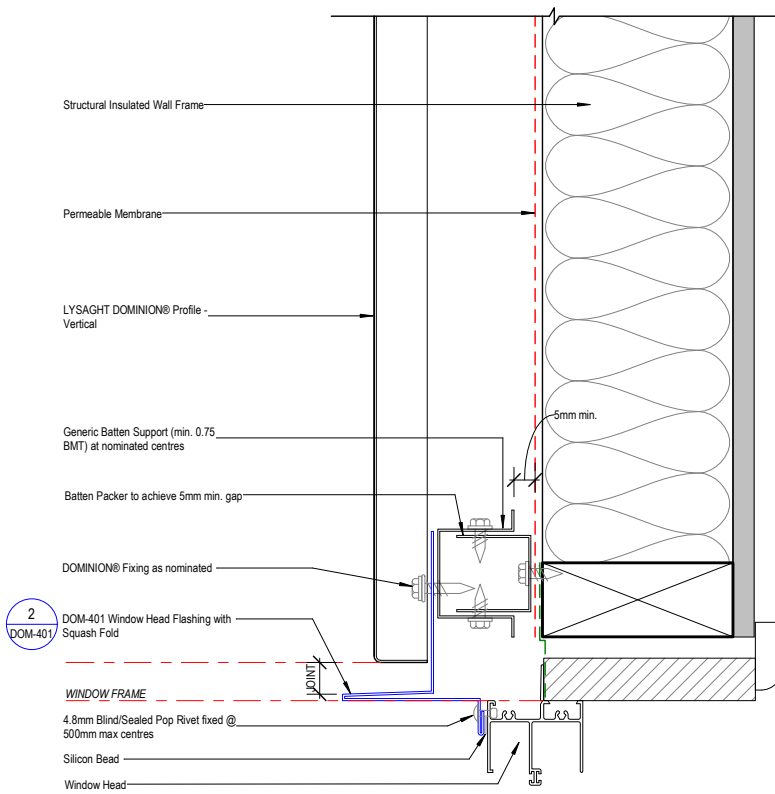
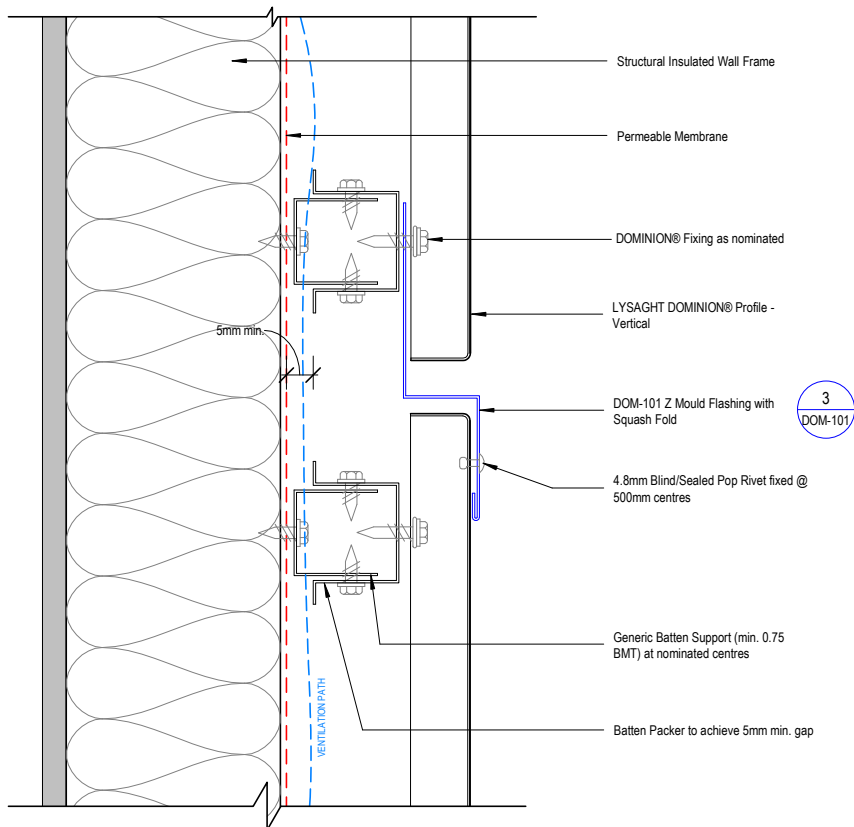

Figure 13.3.2.14

Wall Sheet Joint Detail - Unsupported DOMINION® Panel - Vertical Fix - Sectional View - D12-18



13.3.3 DOMINION® TYPICAL FLASHINGS

Figure 13.3.3.1:

DOM-100 - J Mould Flashings

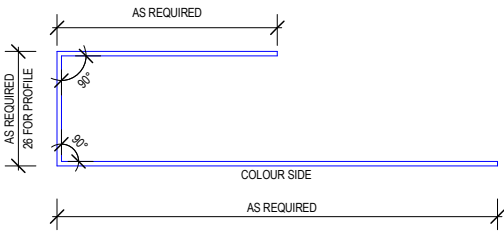
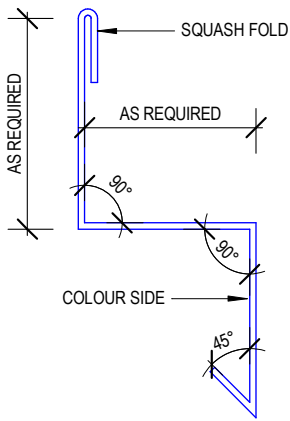
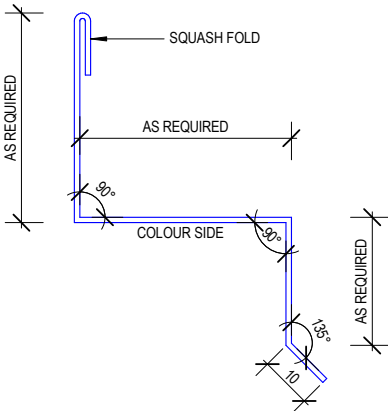

Figure 13.3.3.2:

DOM-101 - Z Mould with Squash Fold and return (left)



DOM-101 - Z Mould with Squash Fold and return (right)



DOM-101 - Z Mould Flashing with Squash Fold

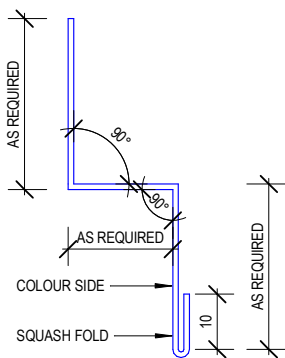
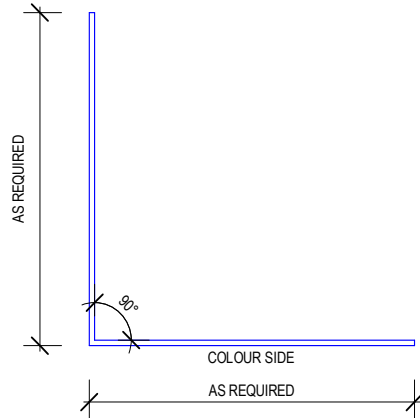
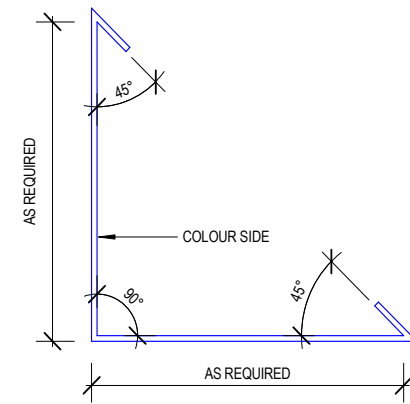

Figure 13.3.3.3:

DOM-102 - L Mould Flashing



DOM-102 - L Mould Flashing with Returns



DOM-102 - L Mould Flashing with Squash Folds

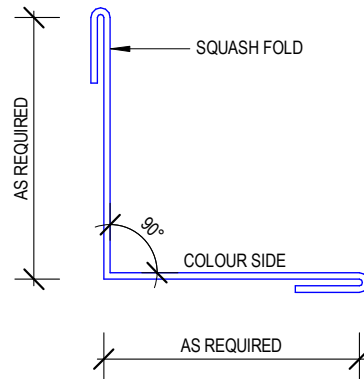

Figure 13.3.3.4:

DOM-103 - Apron Flashing

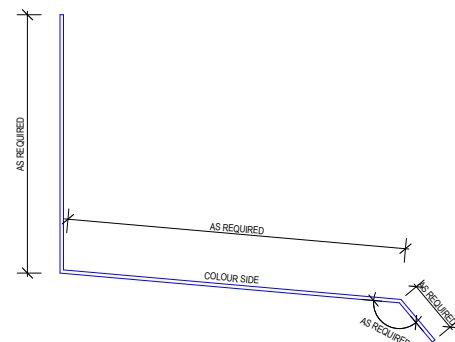

Figure 13.3.3.5:

DOM-104 - U Mould Flashing

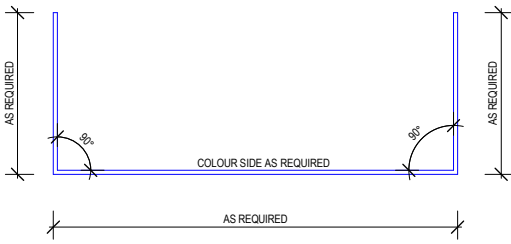

Figure 13.3.3.6:

DOM-200 - External Corner Over Flashing

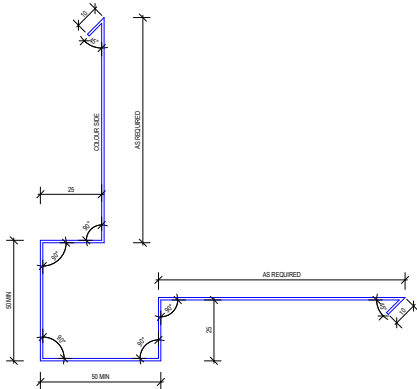

Figure 13.3.3.7:

DOM-201 - Single Return Over Flashing

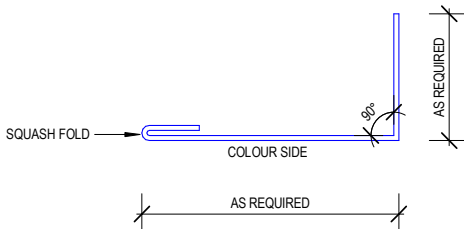
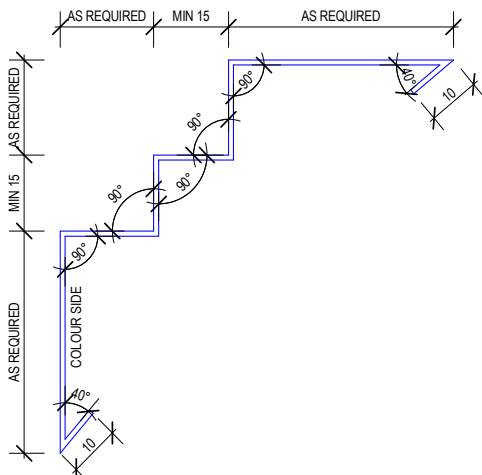

Figure 13.3.3.8:

DOM-202 - Internal Corner Flashings with Returns



DOM-202 - Internal Corner Flashings with Squash Folds

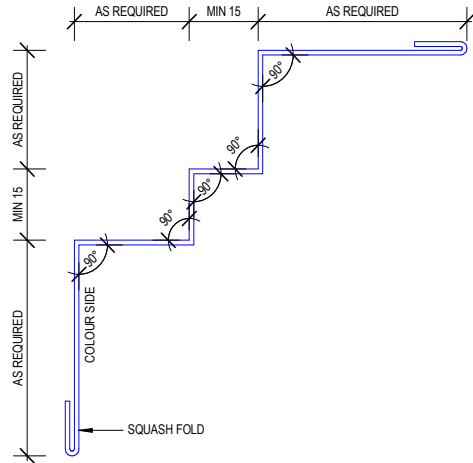

Figure 13.3.3.9:

DOM-203 - Base flashing with Squash Fold

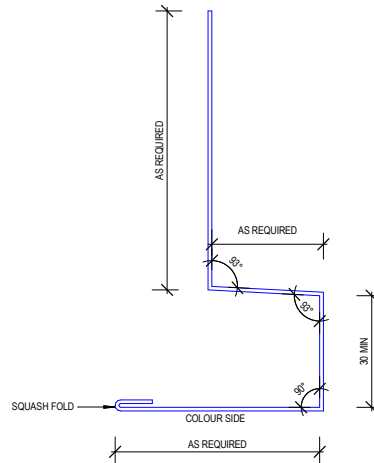

Figure 13.3.3.10:

DOM-204 - Aluminium Base Flashing with Ventilation

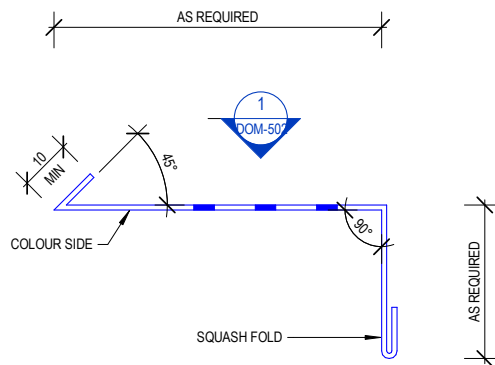

Figure 13.3.3.11:

DOM-205 - Top of Wall Flashing

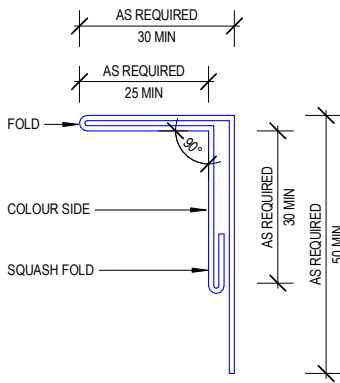
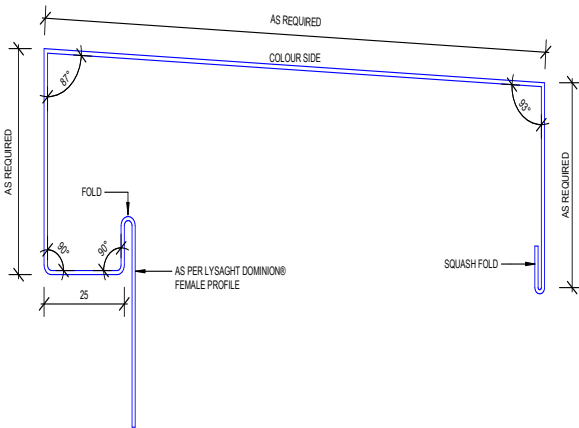

Figure 13.3.3.12:

DOM-206 - Parapet Top Flashing with female return & Squash Fold



DOM-206 - Parapet Top Angled Flashing with return & Squash Fold

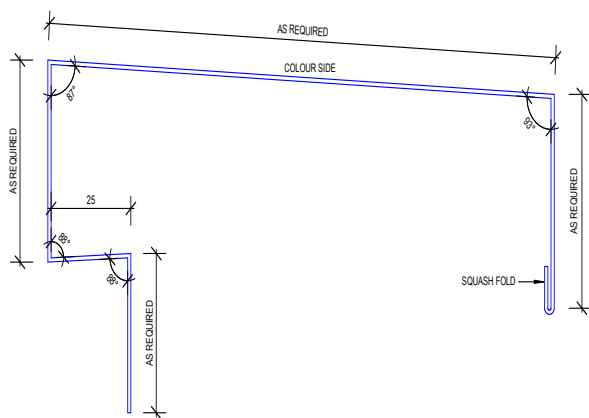
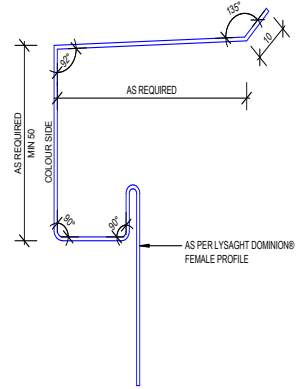

Figure 13.3.3.13:

DOM-400 - Window Sill Flashing with female return



DOM-400 - Window Sill Angled Flashing with return

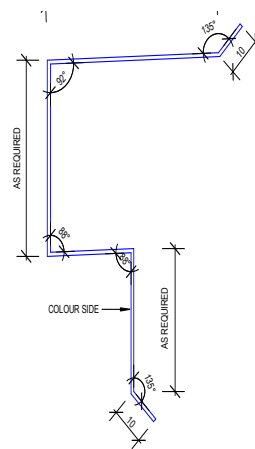
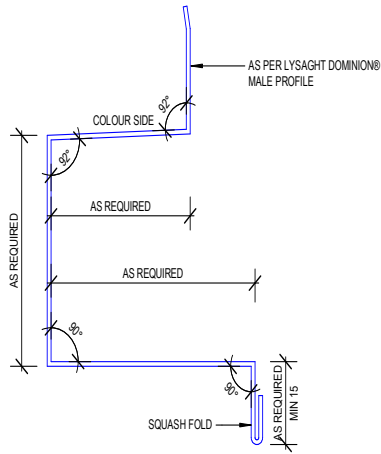

Figure 13.3.3.14:

DOM-401 - Window Head Male Profile Flashing with Squash Fold



DOM-401 - Window Head Flashing with Squash Fold

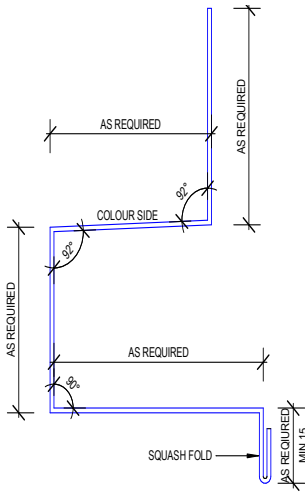
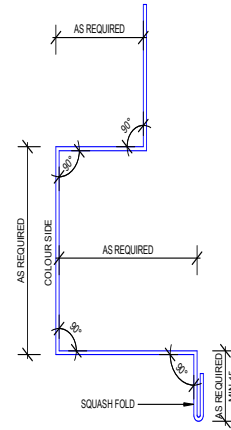

Figure 13.3.3.15:

DOM-402 - Window Jamb Flashing with Squash Fold



DOM-402 - Window Jamb Female Flashing with Squash Fold

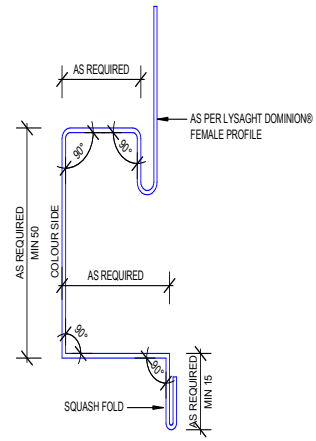
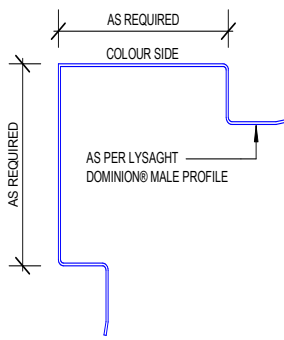
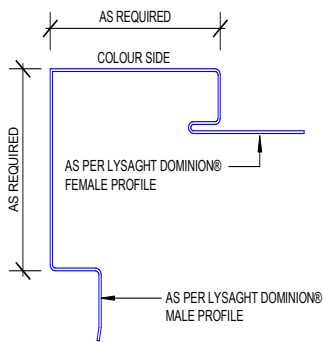

Figure 13.3.3.16:

DOM-500 - External Corner Details - male male



DOM-500 - External Corner Details - female male



DOM-500 - External Corner Details - female female

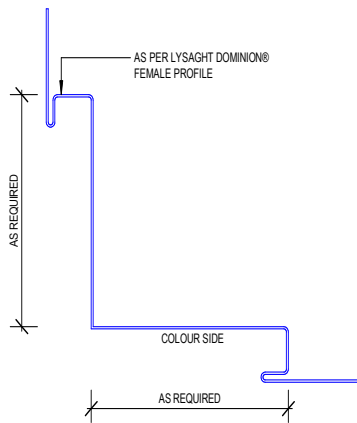
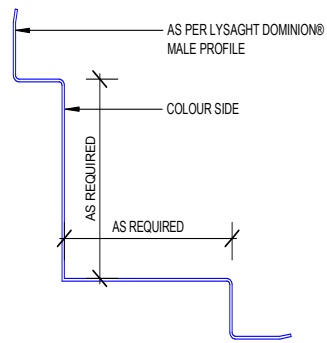
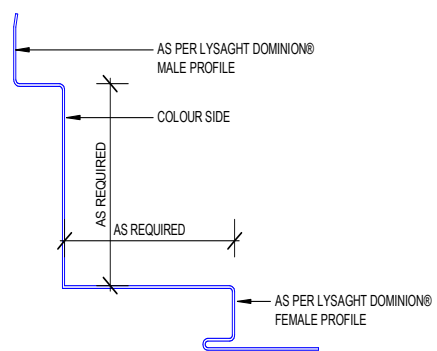

Figure 13.3.3.17:

DOM-501 - Internal Corner Details - male male



DOM-501 - Internal Corner Details - female male



DOM-501 - Internal Corner Details - female female

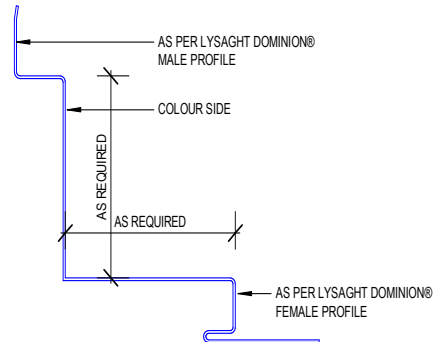

Figure 13.3.3.18:

DOM-502 - Perforation Detail

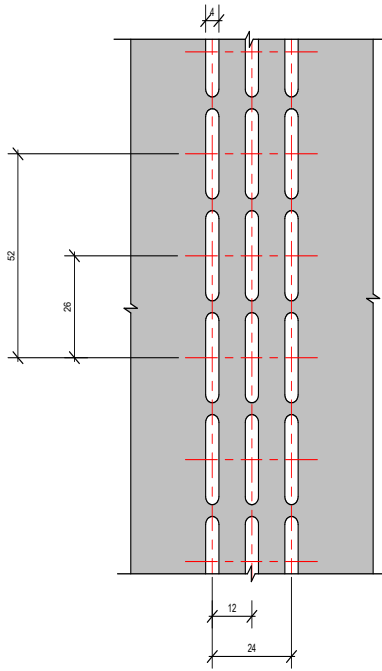

Figure 13.3.3.19:

DOM-504 - Corrosion Resistant Flashing

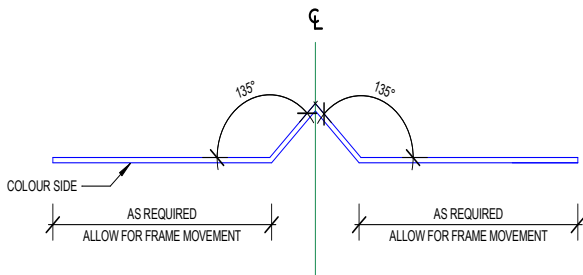
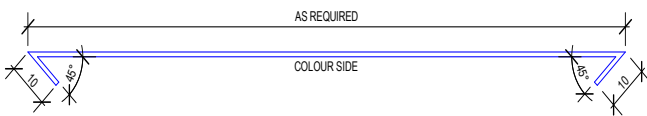

Figure 13.3.3.20:

DOM-505 - Backing Plate Flashing with returns



PRODUCT DESCRIPTIONS

- All descriptions, specifications, illustrations, drawings, data, dimensions, and weights contained in this publication and websites containing information from Lysaght are approximations only. They are intended by Lysaght to be a general description for information and identification purposes and do not create a sale by description. Lysaght reserves the right at any time to:

(a) Supply goods with such minor modifications from its drawings and specifications as it sees fit, and

b) Alter specifications shown in its publications and websites to reflect changes made after the date of publication.

DISCLAIMER, WARRANTIES AND LIMITATION OF LIABILITY

- This publication is intended to be an aid for all trades and professionals involved with specifying and installing LYSAGHT® products and not be a substitute for professional judgement.
- Terms and conditions of sale are available at lysaght.com/terms
- Except to the extent to which liability may not lawfully be excluded or limited, BlueScope Steel Limited will not be under or incur any liability to you for any direct or indirect loss or damage (including, without limitation, consequential loss or damage such as loss of profit or anticipated profit, loss of use, damage to goodwill and loss due to delay) however caused (including, without limitation, breach of contract, negligence and/or breach of statute), which you may suffer or incur in connection with this publication.

FOR DETAILED PRODUCT INFORMATION,
MANUALS AND PROJECT CASE STUDIES VISIT:

[WWW.LYSAGHT.COM](https://www.lysaght.com)

Thermatech® solar reflectance technology is not available in Night Sky®, or non-standard colours, and is not available in SUPERDURA® Stainless steel, COLORBOND® Metallic steel, or COLORBOND® Coolmax® steel.

COLORBOND®, SUPERDURA®, ZINCALUME®, Thermatech®, LYSAGHT® and © product names are registered trademarks of BlueScope Steel Limited and ™ product names are trademarks of BlueScope Steel Limited. © 2024 BlueScope Steel Limited. ABN 16 000 011 058. All rights reserved.

INSPIRATION TO BUILD BETTER

